

Service Manual

LBP3000/2900 Series

Canon

Feb 23 2005

Application

This manual has been issued by Canon Inc. for qualified persons to learn technical theory, installation, maintenance, and repair of products. This manual covers all localities where the products are sold. For this reason, there may be information in this manual that does not apply to your locality.

Corrections

This manual may contain technical inaccuracies or typographical errors due to improvements or changes in products. When changes occur in applicable products or in the contents of this manual, Canon will release technical information as the need arises. In the event of major changes in the contents of this manual over a long or short period, Canon will issue a new edition of this manual.

The following paragraph does not apply to any countries where such provisions are inconsistent with local law.

Trademarks

The product names and company names used in this manual are the registered trademarks of the individual companies.

Copyright

This manual is copyrighted with all rights reserved. Under the copyright laws, this manual may not be copied, reproduced or translated into another language, in whole or in part, without the written consent of Canon Inc.

COPYRIGHT © 2001 CANON INC.









Printed in Japan

Caution

Use of this manual should be strictly supervised to avoid disclosure of confidential information.



Symbols Used

This documentation uses the following symbols to indicate special information:

Symbol	Description
	Indicates an item of a non-specific nature, possibly classified as Note, Caution, or Warning.
	Indicates an item requiring care to avoid electric shocks.
	Indicates an item requiring care to avoid combustion (fire).
	Indicates an item prohibiting disassembly to avoid electric shocks or problems.
	Indicates an item requiring disconnection of the power plug from the electric outlet.
 Memo	Indicates an item intended to provide notes assisting the understanding of the topic in question.
 REF.	Indicates an item of reference assisting the understanding of the topic in question.
	Provides a description of a service mode.
	Provides a description of the nature of an error indication.

The following rules apply throughout this Service Manual:

1. Each chapter contains sections explaining the purpose of specific functions and the relationship between electrical and mechanical systems with reference to the timing of operation.

In the diagrams,  represents the path of mechanical drive; where a signal name accompanies the symbol, the arrow  indicates the direction of the electric signal.

The expression "turn on the power" means flipping on the power switch, closing the front door, and closing the delivery unit door, which results in supplying the machine with power.

2. In the digital circuits, '1' is used to indicate that the voltage level of a given signal is "High", while '0' is used to indicate "Low". (The voltage value, however, differs from circuit to circuit.) In addition, the asterisk (*) as in "DRMD*" indicates that the DRMD signal goes on when '0'.

In practically all cases, the internal mechanisms of a microprocessor cannot be checked in the field. Therefore, the operations of the microprocessors used in the machines are not discussed: they are explained in terms of from sensors to the input of the DC controller PCB and from the output of the DC controller PCB to the loads.

The descriptions in this Service Manual are subject to change without notice for product improvement or other purposes, and major changes will be communicated in the form of Service Information bulletins.

All service persons are expected to have a good understanding of the contents of this Service Manual and all relevant Service Information bulletins and be able to identify and isolate faults in the machine."

Contents

Chapter 1 PRODUCT DESCRIPTION

1.1 Features	1- 1
1.1.1Features	1- 1
1.1.2Features	1- 1
1.2 Product Specifications	1- 2
1.2.1Machine Specifications	1- 2
1.2.2Machine Specifications	1- 3
1.3 Name of Parts	1- 6
1.3.1External View	1- 6
1.3.2External View	1- 6
1.3.3Cross Section View	1- 7
1.4 Using the Machine.	1- 9
1.4.1Control Panel	1- 9
1.5 Safety	1- 10
1.5.1Safety of Laser Light	1- 10
1.5.2Regulations Under the Center for Devices and Radiological Health (CDRH)	1- 10
1.5.3Safety of Toner	1- 10
1.5.4Handling the Laser Unit	1- 11

Chapter 2 TECHNICAL REFERENCE

2.1 Functional Configuration	2- 1
2.1.1Outline	2- 1
2.2 Basic Sequense	2- 2
2.2.1Basic Operation Sequence	2- 2
2.2.2Power-on sequence	2- 3
2.3 LASER EXPOSURE SYSTEM	2- 4
2.3.1 Overview/Configuration	2- 4
2.3.1.1 Overview	2- 4
2.3.2 Controlling the Laser Activation Timing	2- 5
2.3.2.1 Turning On/Off the Laser	2- 5
2.3.2.2 Horizontal Synchronization Control	2- 6
2.3.3 Laser Control	2- 6
2.3.3.1 Auto Photo Current Control	2- 6
2.3.4 Laser Scanner Motor Control	2- 7
2.3.4.1 Outline	2- 7
2.3.4.2 Scanner Motor Speed Control	2- 8
2.3.4.3 Detection of a Fault in the Scanner Motor	2- 8
2.4 IMAGE FORMATION SYSTEM	2- 9
2.4.1 Overview/Configuration	2- 9
2.4.1.1 Construction	2- 9
2.4.1.2 Printing Process	2- 9
2.4.1.3 Latent Image Formation Block	2- 11

2.4.1.4 Development Block	2- 12
2.4.1.5 Transfer Block	2- 13
2.4.1.6 Fixing Block	2- 14
2.4.1.7 Drum Cleaning Block	2- 15
2.4.2 High-Voltage Control	2- 16
2.4.2.1 Outline	2- 16
2.4.2.2 Generation of the Primary Charging Bias.....	2- 17
2.4.2.3 Generation of the Developing Bias.....	2- 17
2.4.2.4 Generation of the Transfer Charging Bias	2- 18
2.4.3 Toner Cartridge	2- 18
2.4.3.1 Checking the Presence/Absence of a Toner Cartridge	2- 18
2.4.3.2 Checking the Level of Toner	2- 19
2.5 PICKUP AND FEEDING SYSTEM.....	2- 20
2.5.1 Overview/Configuration	2- 20
2.5.1.1 Outline	2- 20
2.5.2 Detecting Jams	2- 21
2.5.2.1 Jam Detection Outline	2- 21
2.5.2.2 Delay Jams	2- 22
2.5.2.3 Stationary Jams	2- 22
2.5.2.4 Other Jams	2- 23
2.5.3 Multi-purpose Pickup	2- 23
2.5.3.1 Pickup from the Pickup Tray/Manual Feed Tray	2- 23
2.6 EXTERNAL AND CONTROLS SYSTEM.....	2- 25
2.6.1 Power Supply	2- 25
2.6.1.1 Power Supply	2- 25
2.6.1.2 Protective Functions	2- 26
2.7 ENGINE CONTROL SYSTEM.....	2- 28
2.7.1 Video Controller	2- 28
2.7.1.1 Overview	2- 28
2.7.1.2 Outline of Operation by Block.....	2- 28
2.7.2 Engine Controller	2- 29
2.7.2.1 Outline	2- 29
2.8 FIXING UNIT/DELIVERY SYSTEM	2- 31
2.8.1 Overview/Configuration	2- 31
2.8.1.1 Overview	2- 31
2.8.1.2 Major Components of the Fixing Assembly	2- 32
2.8.2 Various Control Mechanisms	2- 32
2.8.2.1 Fixing Temperature Control	2- 32
2.8.2.2 Protective Functions	2- 35

Chapter 3 DISASSEMBLY AND ASSEMBLY

3.1 EXTERNAL AND CONTROLS SYSTEM.....	3- 1
3.1.1 Rear Cover.....	3- 1
3.1.1.1 Removing the Right Cover	3- 1
3.1.1.2 Removing the Left Cover	3- 1
3.1.1.3 Removing the Front Cover	3- 2
3.1.1.4 Removing the Upper Cover	3- 2
3.1.1.5 Removing the Rear Cover.....	3- 3

3.1.2 Right Cover	3- 3
3.1.2.1 Removing the Right Cover	3- 3
3.1.3 Left Cover	3- 3
3.1.3.1 Removing the Left Cover	3- 3
3.1.4 Upper Cover	3- 4
3.1.4.1 Removing the Right Cover	3- 4
3.1.4.2 Removing the Left Cover	3- 4
3.1.4.3 Removing the Front Cover	3- 5
3.1.4.4 Removing the Upper Cover	3- 5
3.1.5 Front Cover	3- 6
3.1.5.1 Removing the Right Cover	3- 6
3.1.5.2 Removing the Left Cover	3- 7
3.1.5.3 Removing the Front Cover	3- 7
3.1.6 Delivery Tray	3- 7
3.1.6.1 Removing the Delivery Tray	3- 7
3.1.7 Pickup Tray	3- 8
3.1.7.1 Removing the Pickup Tray	3- 8
3.1.8 Engine controller board	3- 8
3.1.8.1 Removing the Right Cover	3- 8
3.1.8.2 Removing the Left Cover	3- 9
3.1.8.3 Removing the Front Cover	3- 9
3.1.8.4 Removing the Engine Controller PCB	3- 9
3.1.9 Video Controller Board	3- 10
3.1.9.1 Removing the Right Cover	3- 10
3.1.9.2 Removing the Video Controller PCB	3- 11
3.1.10 Power supply board	3- 11
3.1.10.1 Removing the Right Cover	3- 11
3.1.10.2 Removing the Left Cover	3- 11
3.1.10.3 Removing the Front Cover	3- 12
3.1.10.4 Removing the Upper Cover	3- 12
3.1.10.5 Removing the Rear Cover	3- 13
3.1.10.6 Removing the Power Supply PCB	3- 13
3.1.11 Top sensor	3- 14
3.1.11.1 Removing the Right Cover	3- 14
3.1.11.2 Removing the Left Cover	3- 14
3.1.11.3 Removing the Front Cover	3- 15
3.1.11.4 Removing the Upper Cover	3- 15
3.1.11.5 Removing the Rear Cover	3- 16
3.1.11.6 Removing the Paper Leading Edge/Paper Width Sensor PCB	3- 16
3.2 LASER EXPOSURE SYSTEM	3- 17
3.2.1 Laser Scanner Unit	3- 17
3.2.1.1 Removing the Right Cover	3- 17
3.2.1.2 Removing the Left Cover	3- 17
3.2.1.3 Removing the Front Cover	3- 18
3.2.1.4 Removing the Engine Controller PCB	3- 18
3.2.1.5 Removing the Laser Scanner Unit	3- 19
3.3 IMAGE FORMATION SYSTEM	3- 20
3.3.1 Transfer Charging Roller	3- 20
3.3.1.1 Removing the Transfer Charging Roller	3- 20

3.4 PICKUP AND FEEDING SYSTEM.....	3- 21
3.4.1 Pickup Unit.....	3- 21
3.4.1.1 Removing the Transfer Charging Roller	3- 21
3.4.1.2 Removing the Right Cover	3- 21
3.4.1.3 Removing the Left Cover	3- 21
3.4.1.4 Removing the Front Cover	3- 22
3.4.1.5 Removing the Upper Cover	3- 22
3.4.1.6 Removing the Rear Cover.....	3- 23
3.4.1.7 Removing the Power Supply PCB.....	3- 23
3.4.1.8 Removing the Fixing Assembly	3- 24
3.4.1.9 Removing the Pickup Assembly.....	3- 24
3.4.2 Manual Pickup Roller.....	3- 25
3.4.2.1 Removing the Pickup Roller.....	3- 25
3.4.3 Multi-purpose Pickup Solenoid.....	3- 25
3.4.3.1 Removing the Right Cover	3- 25
3.4.3.2 Removing the Pickup Solenoid.....	3- 25
3.4.4 Manual Separation Pad.....	3- 26
3.4.4.1 Removing the Separation Pad.....	3- 26
3.4.5 Main Motor	3- 26
3.4.5.1 Removing the Right Cover	3- 26
3.4.5.2 Removing the Left Cover	3- 26
3.4.5.3 Removing the Front Cover	3- 27
3.4.5.4 Removing the Engine Controller PCB.....	3- 27
3.4.5.5 Removing the Laser Scanner Unit.....	3- 28
3.4.5.6 Removing the Main Motor	3- 28
3.5 FIXING SYSTEM.....	3- 29
3.5.1 Fixing Unit	3- 29
3.5.1.1 Removing the Right Cover	3- 29
3.5.1.2 Removing the Left Cover	3- 29
3.5.1.3 Removing the Front Cover	3- 30
3.5.1.4 Removing the Upper Cover	3- 30
3.5.1.5 Removing the Rear Cover.....	3- 31
3.5.1.6 Removing the Power Supply PCB.....	3- 31
3.5.1.7 Removing the Fixing Assembly	3- 31
3.5.2 Fixing Film Unit	3- 32
3.5.2.1 Removing the Right Cover	3- 32
3.5.2.2 Removing the Left Cover	3- 32
3.5.2.3 Removing the Front Cover	3- 33
3.5.2.4 Removing the Upper Cover	3- 33
3.5.2.5 Removing the Rear Cover.....	3- 34
3.5.2.6 Removing the Power Supply PCB.....	3- 34
3.5.2.7 Removing the Fixing Assembly	3- 34
3.5.2.8 Removing the Fixing Film Unit.....	3- 35
3.5.3 Fixing Pressure Roller.....	3- 35
3.5.3.1 Removing the Right Cover	3- 35
3.5.3.2 Removing the Left Cover	3- 36
3.5.3.3 Removing the Front Cover	3- 36
3.5.3.4 Removing the Upper Cover	3- 36
3.5.3.5 Removing the Rear Cover.....	3- 37

3.5.3.6 Removing the Power Supply PCB	3- 37
3.5.3.7 Removing the Fixing Assembly	3- 38
3.5.3.8 Removing the Fixing Film Unit	3- 38
3.5.3.9 Removing the Pressure Roller	3- 39
3.5.4 Delivery Sensor	3- 39
3.5.4.1 Removing the Right Cover	3- 39
3.5.4.2 Removing the Left Cover	3- 39
3.5.4.3 Removing the Front Cover	3- 40
3.5.4.4 Removing the Upper Cover	3- 40
3.5.4.5 Removing the Rear Cover	3- 41
3.5.4.6 Removing the Delivery Sensor	3- 41

Chapter 4 MAINTENANCE AND INSPECTION

4.1 Periodically Replaced Parts	4- 1
4.1.1 Periodic Replacement Parts	4- 1
4.2 Consumables	4- 2
4.2.1 Consumable Parts	4- 2
4.3 Periodical Service	4- 3
4.3.1 Periodic Service	4- 3
4.4 Cleaning	4- 4
4.4.1 Items to Clean	4- 4
4.4.2 Cleaning (external covers)	4- 4
4.4.3 Cleaning (printer unit)	4- 5

Chapter 5 TROUBLESHOOTING

5.1 Countermeasures	5- 1
5.1.1 Image Faults	5- 1
5.1.1.1 Partially Blank/Streaked	5- 1
5.1.1.2 Smudged/Streaked	5- 1
5.1.1.3 Ghost / Memory	5- 2
5.2 MEASUREMENT AND ADJUSTMENT	5- 5
5.2.1 Mechanical Adjustment	5- 5
5.2.1.1 Checking the Pressure of the Pressure Roller (nip)	5- 5
5.3 SERVICE TOOLS	5- 6
5.3.1 Special Tools	5- 6
5.3.2 Solvent/Oil List	5- 6
5.4 Location of Convector	5- 7
5.4.1 Location of Convector	5- 7
5.5 ERROR CODE TABLE	5- 8
5.5.1 Overview	5- 8
5.5.2 Service Messages	5- 8

Chapter 6 APPENDIX

6.1 OUTLINE OF ELECTRICAL COMPONENTS	6- 1
6.1.1 Clutch/Solenoid	6- 1
6.1.1.1 Solenoid	6- 1

6.1.2 Motor	6- 1
6.1.2.1 Motor	6- 1
6.1.3 Sensor	6- 2
6.1.3.1 Sensor	6- 2
6.1.4 Switch	6- 3
6.1.4.1 Switch	6- 3
6.1.5 Lamps, Heaters, and Others	6- 4
6.1.5.1 Heater	6- 4
6.1.6 PCBs	6- 5
6.1.6.1 PCBs	6- 5

Chapter 1 PRODUCT DESCRIPTION

Contents

1.1 Features	1-1
1.1.1 Features	1-1
1.1.2 Features	1-1
1.2 Product Specifications	1-2
1.2.1 Machine Specifications	1-2
1.2.2 Machine Specifications	1-3
1.3 Name of Parts	1-6
1.3.1 External View	1-6
1.3.2 External View	1-6
1.3.3 Cross Section View	1-7
1.4 Using the Machine	1-9
1.4.1 Control Panel	1-9
1.5 Safety	1-10
1.5.1 Safety of Laser Light	1-10
1.5.2 Regulations Under the Center for Devices and Radiological Health	1-10
1.5.3 Safety of Toner	1-10
1.5.4 Handling the Laser Unit	1-11

1.1 Features

1.1.1 Features

0007-9872

1. High-Speed, Compact Mono-Color Printer

The machine's body is compact in design perfectly suited for installation on a desk, and yet it is a mono-color printer capable of turning out as many as 14.6 prints (LTR) every minute.

2. Shorter Wait Time and Lower Power Consumption

The machine uses an on-demand fixing method, enabling a shorter wait time and lower power consumption when compared with machines that use a roller fixing method.

1.1.2 Features

0009-2599

1. High-Speed, Compact Mono-Color Printer

The machine's body is compact in design perfectly suited for installation on a desk, and yet it is a mono-color printer capable of turning out as many as 12.0 prints (A4) every minute.

2. Shorter Wait Time and Lower Power Consumption

The machine uses an on-demand fixing method, enabling a shorter wait time and lower power consumption when compared with machines that use a roller fixing method.

1.2 Product Specifications

1.2.1 Machine Specifications

0007-5859

Body installation method	desktop page printer
Photosensitive medium	OPC drum
Exposure method	semiconductor laser
Development method	toner projection
Transfer method	roller transfer
Separation method	curvature separation
Cassette pickup method	pad separation (pickup from pickup tray)
Multifeeder pickup method	pad separation (pickup from manual feed tray)
Drum cleaning method	blade
Fixing method	on-demand fixing
Delivery method	face-down
Toner supply type	toner cartridge (about 2000 prints; A4, single-sided, image ratio of 5%)
Warm-up time	0 sec (from standby; if from power-on, 10 sec or less)
Print area	area 5 mm from paper edges
Printing resolution	600 dpi
First print time	9.3 sec or less (approx.; A4)
Print speed (A4)	14 pages/min (approx.)
Print speed(LTR)	14.6 pages/min (approx.)
Cassette paper size	A4, B5, A5, LGL, LTR, Executive, postcard, envelope, user-defined paper (76.2 to 215.9 mm in width, 127 to 355.6 mm in length)
Multi-purpose paper size	A4, B5, A5, LGL, LTR, Executive, postcard, envelope, user-defined paper (76.2 to 215.9 mm in width, 127 to 355.6 mm in length)

Cassette paper type	plain paper (64 to 90 g/m ²), heavy paper (91 to 163 g/m ²), recycled paper, transparency, label sheet, postcard, envelope
Multi-purpose paper type	plain paper (64 to 90 g/m ²), heavy paper (91 to 163 g/m ²), recycled paper, transparency, label sheet, postcard, envelope
Cassette capacity	if plain paper, about 150 sheets (64g/m ²); if heavy paper, about 60 sheets (128g/m ²);if transparency, about 100 sheets;if postcard, about 30 sheets
Multi-purpose capacity	1 sheet
Delivery tray stack	if plain paper, about 100 sheets (64g/m ²); if heavy paper, about 30 sheets (128g/m ²);if transparency, label sheet, envelope, or postcard, about 10 sheets
Memory	2 MB (internal; no option)
Operating environment (Temperature range)	7.5 to 35 deg C
Operating environment (Humidity range)	5% to 90% RH
Noise	62 dB or less (during printing; nominal noise rating based on ISO9296)
Power supply rating	110 to 127 VAC +/-10% (50/60 Hz +/-2 Hz); 220 to 240 VAC +/-10% (50 Hz +/-2 Hz)
Power consumption (Maximum)	body standard: 830 W or less (approx.; at 20 deg C room temperature; including peak values in excess of 1 sec at input of rated power)
Dimensions	370 (W) x 251 (D) x 216 (H) mm (approx.)
Weight	printer unit: about 5.3 kg; toner cartridge: about 0.7kg
Option	none

1.2.2 Machine Specifications

0009-2729

Body installation method	desktop page printer
Photosensitive medium	OPC drum
Exposure method	semiconductor laser

Development method	toner projection
Transfer method	roller transfer
Separation method	curvature separation
Cassette pickup method	pad separation (pickup from pickup tray)
Multifeeder pickup method	pad separation (pickup from manual feed tray)
Drum cleaning method	blade
Fixing method	on-demand fixing
Delivery method	face-down
Toner supply type	toner cartridge (about 2000 prints; A4, single-sided, image ratio of 5%)
Warm-up time	0 sec (from standby; if from power-on, 10 sec or less)
Print area	area 5 mm from paper edges
Printing resolution	600dpi
First print time	9.3 sec or less (approx.; A4)
Print speed (A4)	12 pages/min (approx.)
Print speed(LTR)	12 pages/min (approx.)
Cassette paper size	A4, B5, A5, LGL, LTR, Executive, postcard, envelope, user-defined paper (76.2 to 215.9 mm in width, 127 to 355.6 mm in length)
Multi-purpose paper size	A4, B5, A5, LGL, LTR, Executive, postcard, envelope, user-defined paper (76.2 to 215.9 mm in width, 127 to 355.6 mm in length)
Cassette paper type	plain paper (64 to 90 g/m ²), heavy paper (91 to 163 g/m ²), recycled paper, transparency, label sheet, postcard, envelope
Multi-purpose paper type	plain paper (64 to 90 g/m ²), heavy paper (91 to 163 g/m ²), recycled paper, transparency, label sheet, postcard, envelope
Cassette capacity	if plain paper, about 150 sheets (64g/m ²); if heavy paper, about 60 sheets (128g/m ²);if transparency, about 100 sheets;if postcard, about 30 sheets
Multi-purpose capacity	1 sheet
Delivery tray stack	if plain paper, about 100 sheets (64g/m ²); if heavy paper, about 30 sheets (128g/m ²);if transparency, label sheet, envelope, or postcard, about 10 sheets

Memory	2 MB (internal; no option)
Operating environment (Temperature range)	7.5 to 35 deg C
Operating environment (Humidity range)	5 ~ 90%RH
Noise	62 dB or less (during printing; nominal noise rating based on ISO9296)
Power supply rating	220 to 240 VAC +/-10% (50 Hz +/-2 Hz)
Power consumption (Maximum)	body standard: 830 W or less (approx.; at 20 deg C room temperature; including peak values in excess of 1 sec at input of rated power)
Dimensions	370 (W) x 251 (D) x 216 (H) mm (approx.)
Weight	printer unit: about 5.3 kg; toner cartridge: about 0.7kg
Option	none

1.3 Name of Parts

1.3.1 External View

0007-6025

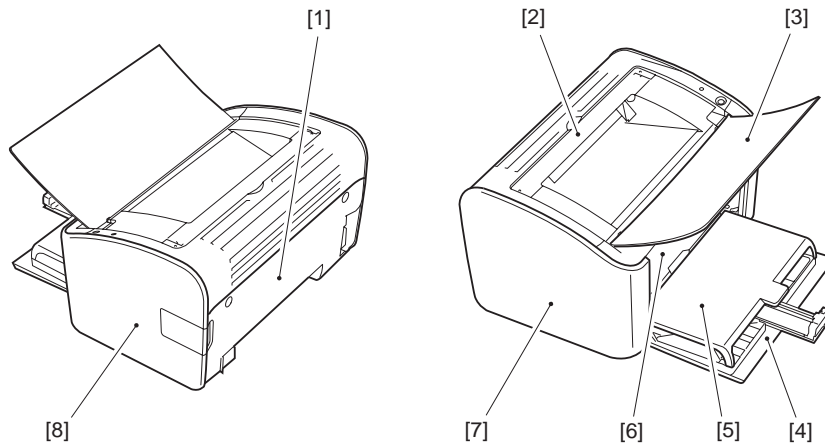

F-1-1

T-1-1

- | | |
|-------------------|-----------------|
| [1] Rear cover | [6] Front cover |
| [2] Upper cover | [7] Left cover |
| [3] Delivery tray | [8] Right cover |
| [4] Pickup tray | |
| [5] Tray cover | |

1.3.2 External View

0009-2753

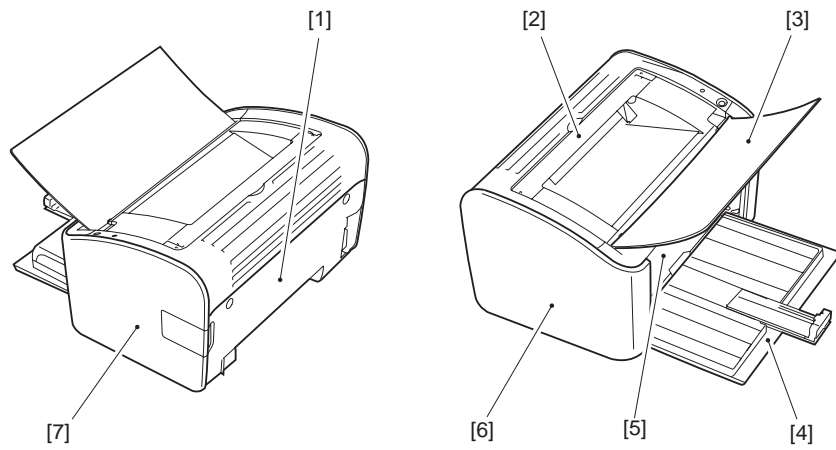

F-1-2

T-1-2

[1] Rear cover

[2] Upper cover

[3] Delivery tray

[4] Pickup tray

[5] Front cover

[6] Left cover

[7] Right cover

1.3.3 Cross Section View

0007-6027

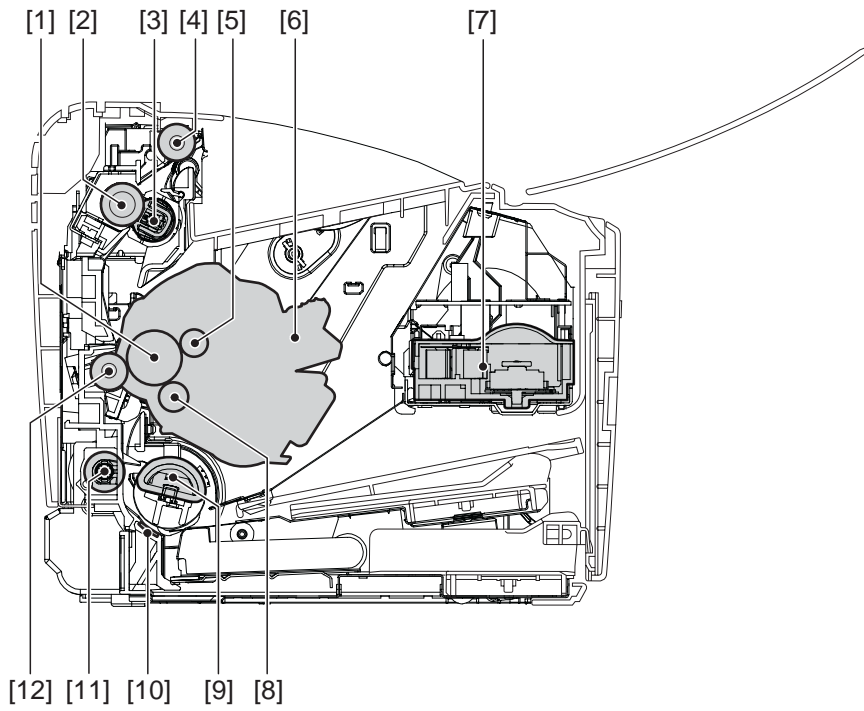

F-1-3

T-1-3

- | | |
|-----------------------------|-------------------------------|
| [1] Photosensitive drum | [8] Developing cylinder |
| [2] Pressure roller | [9] Pickup roller |
| [3] Fixing film assembly | [10] Separation pad |
| [4] Delivery roller | [11] Feed roller |
| [5] Primary charging roller | [12] Transfer charging roller |
| [6] Toner cartridge | |
| [7] Laser scanner assembly | |

1.4 Using the Machine

1.4.1 Control Panel

0007-6034

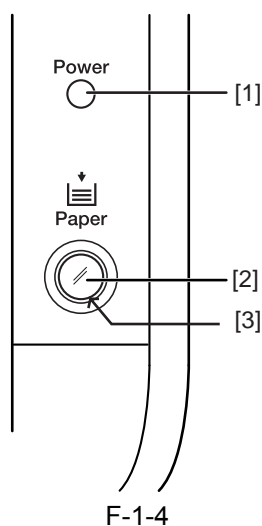

The machine is equipped with 2 lamps and 1 control key:

[1] Power Lamp

ON: indicates that the machine is supplied with power.

OFF: indicates that the machine is not supplied with power.

[2] Paper Lamp

flashing: indicates the absence of paper or the presence of a jam while a job is under way.

OFF: indicates the presence of a service error or the presence of a state other than the above.

[3] Paper Key

A press on this key after supplying paper or removing the jam will cause the machine to resume the suspended printing operation.

1.5 Safety

1.5.1 Safety of Laser Light

0007-6035

Laser radiation could be hazardous to the human body. For this reason, laser radiation emitted inside this machine is hermetically sealed within the protective housing and external cover. No radiation can leak from the machine in the normal operation of the product by the user.

1.5.2 Regulations Under the Center for Devices and Radiological Health (CDRH)

0007-6036

The CDRH of the US Food and Drug Administration put into effect regulations governing the sale of laser products in the US on August 2, 1976. These regulations apply to all laser products produced on and after August 1, 1976, and a laser product cannot be sold unless it has been certified to comply with the regulations. The following is the label used to indicate that the product has been certified under the regulations, and all laser products sold in the US must bear the label.

CANON INC.

30-2,SHIMOMARUKO,3-CHOME,OHTA-KU,TOKYO,
146.JAPAN

MANUFACTURED :

THIS PRODUCT CONFORMS WITH DHHS RADIATION
PERFORMANCE STANDARD 21CFR CHAPTER1
SUBCHAPTER J.

F-1-5

1.5.3 Safety of Toner

0007-6037

The machine's toner is a non-toxic material composed of plastic, iron, and small amounts of dye.



Do not put the toner into fire. It may explode.

Toner on the Skin or Clothes

1. If your skin or clothes came into contact with toner, use dry tissue to remove the toner, and then wash with water.
2. Do not use warm or hot water, which will cause the toner to jell, permanently fusing it with the fibers of the clothes.
3. Do not bring toner into contact with vinyl material. They are likely to react with each other.

1.5.4 Handling the Laser Unit

0007-6038

The laser scanner unit emits invisible laser light inside it. If exposed to laser light, the human eye can irreparably be damaged. Never attempt to disassemble the laser scanner unit. (It is not designed for servicing in the field).

The covers around the laser scanner unit are identified by the following label.



F-1-6

Chapter 2 TECHNICAL REFERENCE

Contents

2.1 Functional Configuration	2-1
2.1.1 Outline	2-1
2.2 Basic Sequense	2-2
2.2.1 Basic Operation Sequence	2-2
2.2.2 Power-on sequence	2-3
2.3 LASER EXPOSURE SYSTEM	2-4
2.3.1 Overview/Configuration	2-4
2.3.1.1 Overview	2-4
2.3.2 Controlling the Laser Activation Timing	2-5
2.3.2.1 Turning On/Off the Laser	2-5
2.3.2.2 Horizontal Synchronization Control	2-6
2.3.3 Laser Control	2-6
2.3.3.1 Auto Photo Current Control	2-6
2.3.4 Laser Scanner Motor Control	2-7
2.3.4.1 Outline	2-7
2.3.4.2 Scanner Motor Speed Control	2-8
2.3.4.3 Detection of a Fault in the Scanner Motor	2-8
2.4 IMAGE FORMATION SYSTEM	2-9
2.4.1 Overview/Configuration	2-9
2.4.1.1 Construction	2-9
2.4.1.2 Printing Process	2-9
2.4.1.3 Latent Image Formation Block	2-11
2.4.1.4 Development Block	2-12
2.4.1.5 Transfer Block	2-13
2.4.1.6 Fixing Block	2-14
2.4.1.7 Drum Cleaning Block	2-15
2.4.2 High-Voltage Control	2-16
2.4.2.1 Outline	2-16
2.4.2.2 Generation of the Primary Charging Bias	2-17
2.4.2.3 Generation of the Developing Bias	2-17
2.4.2.4 Generation of the Transfer Charging Bias	2-18
2.4.3 Toner Cartridge	2-18
2.4.3.1 Checking the Presence/Absence of a Toner Cartridge	2-18
2.4.3.2 Checking the Level of Toner	2-19
2.5 PICKUP AND FEEDING SYSTEM	2-20
2.5.1 Overview/Configuration	2-20
2.5.1.1 Outline	2-20
2.5.2 Detecting Jams	2-21
2.5.2.1 Jam Detection Outline	2-21
2.5.2.1.1 Outline	2-21
2.5.2.2 Delay Jams	2-22
2.5.2.2.1 Pickup Delay Jam	2-22
2.5.2.2.2 Delivery Delay Jam	2-22
2.5.2.3 Stationary Jams	2-22

2.5.2.3.1 Pickup Stationary Jam	2-22
2.5.2.3.2 Delivery Stationary Jam.....	2-23
2.5.2.4 Other Jams	2-23
2.5.2.4.1 Wrapping Jam Around the Fixing Assembly	2-23
2.5.2.4.2 Residual Jam at Start-Up	2-23
2.5.2.4.3 Door Open Jam	2-23
2.5.3 Multi-purpose Pickup	2-23
2.5.3.1 Pickup from the Pickup Tray/Manual Feed Tray	2-23
2.6 EXTERNAL AND CONTROLS SYSTEM.....	2-25
2.6.1 Power Supply	2-25
2.6.1.1 Power Supply	2-25
2.6.1.1.1 Low-Voltage Power Supply Circuit	2-25
2.6.1.2 Protective Functions	2-26
2.6.1.2.1 Protective Mechanisms	2-26
2.7 ENGINE CONTROL SYSTEM.....	2-28
2.7.1 Video Controller	2-28
2.7.1.1 Overview	2-28
2.7.1.2 Outline of Operation by Block.....	2-28
2.7.2 Engine Controller.....	2-29
2.7.2.1 Outline	2-29
2.8 FIXING UNIT/DELIVERY SYSTEM	2-31
2.8.1 Overview/Configuration	2-31
2.8.1.1 Overview	2-31
2.8.1.2 Major Components of the Fixing Assembly	2-32
2.8.2 Various Control Mechanisms	2-32
2.8.2.1 Fixing Temperature Control	2-32
2.8.2.1.1 Heater Temperature Control	2-32
2.8.2.2 Protective Functions	2-35
2.8.2.2.1 Protective Mechanisms	2-35
2.8.2.2.2 Detection of a Fault.....	2-35

2.1 Functional Configuration

2.1.1 Outline

0007-6048

The functions of this printer can be divided into 6 blocks: the engine control system, laser exposure system, image formation system, pickup and feed system, fixing and delivery system, external and control system.

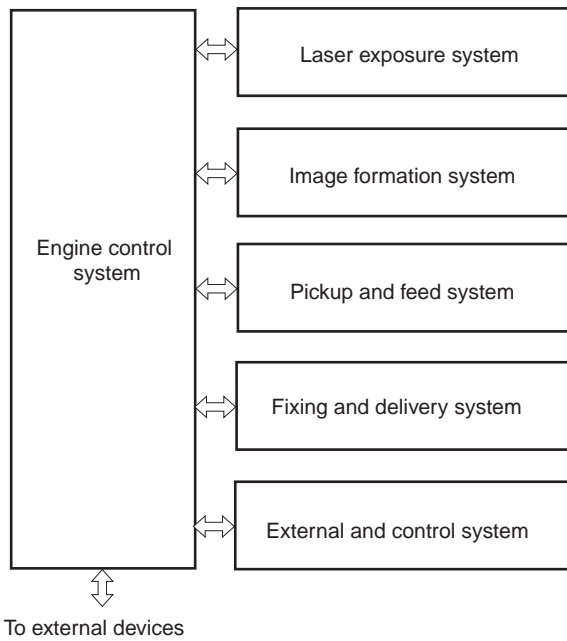

F-2-1

2.2 Basic Sequence

2.2.1 Basic Operation Sequence

0007-9885

The operation sequence of this printer is controlled by the microprocessor (CPU) on the engine controller PCB. The following diagram shows the purposes of each period from power ON until the main motor stops after the completion of printing. See the timing chart.

T-2-1

Period		Purpose	Remarks
WAIT (Wait)	From power-ON until the end of the main motor initial rotation.	To clean the drum surface of potential and to clean the transfer charging roller.	Toner cartridge in/out detection is executed.
STBY (Standby)	From the end of the WAIT period or the LSTR period until the input of the pick-up command from the video controller. Or, from the end of the LSTR period until power-OFF.	To keep the printer ready to print.	
INTR (Initial rotation)	From the input of the print command from the video controller until the pick up solenoid is turned ON	To stabilize the photosensitive drum sensitivity in preparation for printing, Also to clean the transfer charging roller.	
PRINT (Print)	From the end of the initial rotation until the primary high-voltage is turned OFF.	To form image on the photosensitive drum according to the video signals input from the interface controller, and transfers the image to paper.	

LSTR (Last rotation)	From the primary high-voltage is turned OFF until the main motor stops rotating.	Delivers the final page and cleans the transfer charging roller.	As soon as the print command is input from the video controller, the printer enters the INITIAL ROTATION period.
----------------------------	--	--	--

2.2.2 Power-on sequence

0007-9887

The following is the sequence from power ON until the engine controller enters STBY mode.

- 1) Power ON
- 2) CPU initialization
- 3) Video interface communication start
- 4) Residual paper check
Checks the sensors for any residual paper.
- 5) Main motor initial drive
- 6) Fixing heater initial drive
Drive the fixing heater so that the fixing unit reaches its targeted temperature of 100 deg C.
- 7) Scanner motor initial drive
- 8) High-voltage control
Clean the transfer charging roller.
- 9) Failure/ abnormality check
Detects scanner failure, fixing unit failure and door open during the periods mentioned above.

2.3 LASER EXPOSURE SYSTEM

2.3.1 Overview/Configuration

2.3.1.1 Overview

0008-0084

The laser/scanner system serves to form images on the photosensitive drum according to the video signals coming from the video controller, and it consists of a laser driver PCB, scanner motor, and the like, which are housed inside an assembly as a single unit. The laser/scanner system is controlled by the DC controller.

The following is a diagram of the laser/scanner system and a description of its sequence of operation.

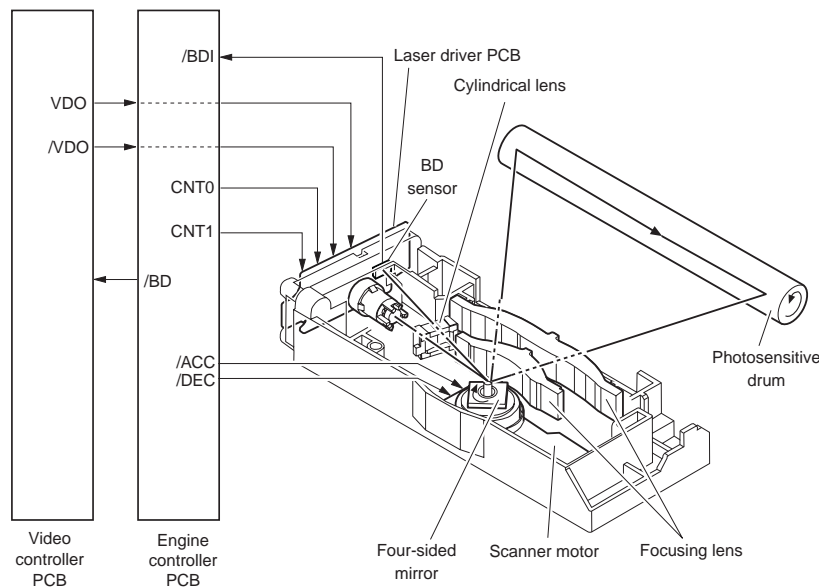

F-2-2

1. When the print command arrives from the video controller, the engine controller turns on the scanner motor to rotate the 4-facet mirror.
2. When the scanner motor starts to rotate, the engine controller uses the laser control signal to force the laser on. Thereafter, the engine controller starts to control the rotation of the scanner motor.
3. The engine controller uses the scanner motor speed control signal to make sure that the scanner motor rotates at a specific speed at all times.
4. When the scanner motor reaches a target rotation speed, the video controller sends video signals to the laser driver PCB.
5. The laser driver turns on the laser diode according to these signals.
6. The laser beam moves through a collimating lens and a cylindrical lens to reach the 4-facet mirror rotating at a specific speed.
7. The beam reflected by the 4-facet mirror then moves through the imaging lens and the reflecting mirror arranged

in front of the 4-facet mirror and focus on the surface of the photosensitive drum.

8. When the 4-facet mirror rotates at a specific speed, the laser beam starts to scan the surface of the photosensitive drum at a specific speed.

9. When the photosensitive drum rotates at a specific speed and, at the same time, the laser beam starts to scan the surface of the photosensitive drum at a specific speed, a static (latent) image starts to form on the surface of the photosensitive drum.

2.3.2 Controlling the Laser Activation Timing

2.3.2.1 Turning On/Off the Laser

0008-0090

The machine controls the activation of the laser according to the laser control signals coming from the engine controller using the laser driver that turns on and off the laser diode (LD). The following shows the circuit used to control the laser.

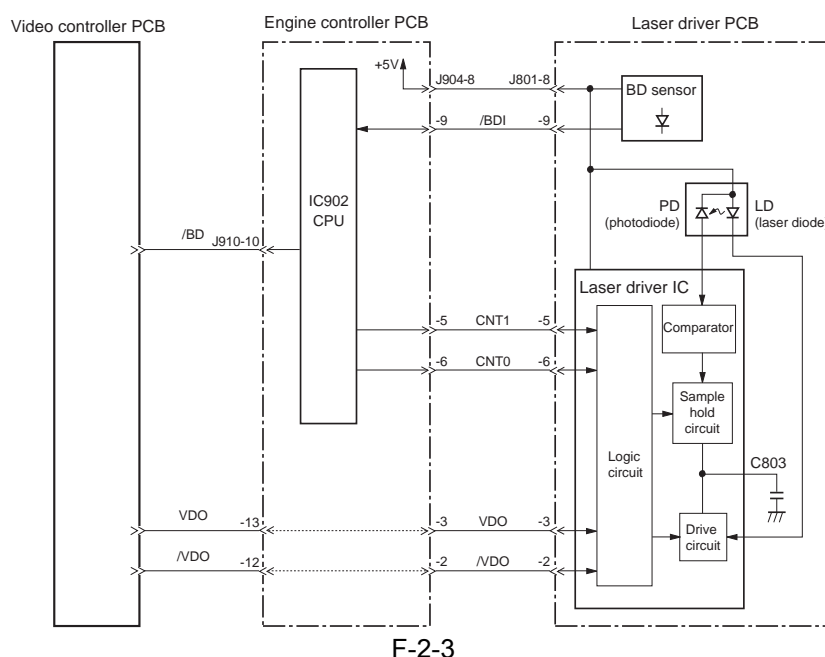

The engine controller is the source of video signals (VDO, /VDO) used for image formation. It is also the source of laser control signals (CNT0, CNT1) sent to the logic circuit inside the laser driver IC for switching over laser operation modes.

The laser driver CI controls the laser with reference to combinations of CTN0 and CNT1 signals as shown in the following table:

T-2-2

Operating mode	CNT	CNT	Uses
	0	1	
Discharge	L	L	C803 discharge
Print	H	L	Normal printing
LD APC	L	H	LD APC
LD forced deactivation	H	H	Image masking

2.3.2.2 Horizontal Synchronization Control

0008-0093

The machine controls horizontal synchronization so as to make sure that the image start position is correct in horizontal direction; specifically,

1. The engine controller turns the laser control signal into LD APC mode during an unblanking period (Note).
2. The BD PCB is located in the optical path of the laser beam to detect the beam.
3. When the BD PCB detects the laser beam, it uses the beam to generate the BD input signal (/BDI) for output to the engine controller.
4. In response, the video controller generates the horizontal sync signal (/BD) for output to the interface controller.
5. When the video controller receives the /BD signal, it sends video signals (VDO, /VDO) to the engine controller in a way that the image start position will be correct in image horizontal direction.



The term "unblanking period" refers to a period of time in which the laser diode is turned on in a non-image area.

2.3.3 Laser Control

2.3.3.1 Auto Photo Current Control

0008-0094

The machine executes auto photo current control to make sure that the laser diode emits light at a specific level of intensity.

APC may be either initial APC (Note 1), which is executed during initial rotation, or interval APC (Note 2), which is executed during printing; however, both of them are executed in the same way as follows:

1. When the laser control signal (CNT0, CNT1) is in LD APC mode, the laser driver forces the laser diode to go on.
2. The intensity of the light from the laser diode is checked by the photodiode (PD), and its current is converted into an appropriate voltage for comparison against a reference voltage (equal to the target laser intensity).
3. The laser driver keeps controlling the laser current until the intensity of the light from the laser diode is equivalent

to the level of voltage of the target intensity.

- Thereafter, when the laser control signal changes to LD forced deactivation mode, the LD is forced to go off, and the laser driver converts the voltage into a capacitor voltage for retention.



Note 1:

The term "initial APC" refers to APC executed during initial rotation and in which the laser intensity is controlled by means of APC.

Note 2:

The term "interval APC" refers to APC executed during printing and in which the laser intensity is adjusted for a single line before the start of the line.

2.3.4 Laser Scanner Motor Control

2.3.4.1 Outline

0008-0095

The machine controls the laser scanner to make sure that the scanner motor rotates at a specific speed at all times. The scanner motor is a 3-phase DC brushless motor possessing a Hall element, and it is constructed as part of the drive circuit.

The following is a diagram showing the circuit used to control the scanner motor:

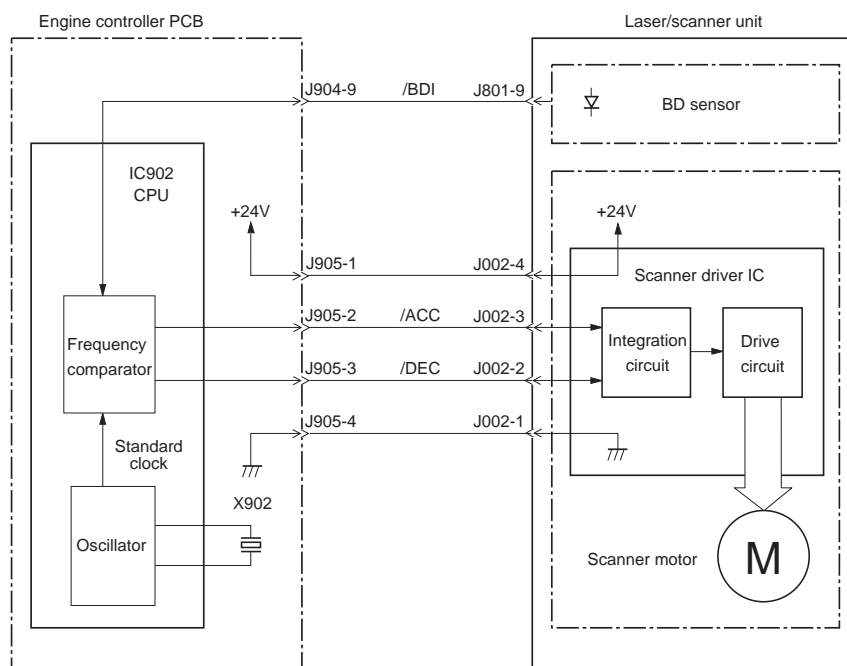

F-2-4

2.3.4.2 Scanner Motor Speed Control

0008-0096

The machine controls the scanner motor so that the motor rotates at a specific speed; specifically,

1. When the scanner motor is starting up, the CPU sends the /ACC signal to the scanner driver IC to force the scanner motor to increase its speed, thereby causing the scanner motor to rotate.
2. The CPU forces the laser to go on at specific intervals, and compares the /BDI signal against the reference clock pulses to find out the revolution of the scanner motor.
3. If the revolution of the scanner motor exceeds a specific value, the CPU generates the /DECK signal to decelerate the scanner motor; thereafter, the CPU controls the /ACC or /DECK signal until the revolution of the scanner motor reaches a specific value, thereby controlling the rotation of the scanner motor.

2.3.4.3 Detection of a Fault in the Scanner Motor

0008-0097

The CPU of the engine controller monitors the frequency comparator to find out whether the scanner motor is rotating at a specific speed. The CPU will assume any of the following conditions to be a fault or error in the scanner motor and stop the engine, while at the same time communicating the fact to the video controller.

1. Scanner Fault

If the /BDI signal cannot be detected 1.5 sec after the end of forced acceleration of the scanner motor, the period of detection will be extended by 120 sec. If the cycle of the /BDI signal is not of a specific value during the period, the machine will assume the fact to indicate a fault in the scanner.

2. BD Fault

If the /BDI signal cannot be detected within 100 msec after the end of the forced acceleration of the scanner motor, or the cycle of the /BDI signal is not a specific value continuously for 2 sec or more after the scanner motor has reached a specific speed, the machine will assume the condition to indicate a BD fault.

3. BD Error

When the /BDI signal is not detected at a specific cycle while the /BDI signal is being generated for the interface controller, the machine will assume the condition to indicate an BD error.

If the door is identified as being open within 200 msec after the detection of a BD error, the CPU will not communicate the presence of a BD error to the interface controller.

2.4 IMAGE FORMATION SYSTEM

2.4.1 Overview/Configuration

2.4.1.1 Construction

0008-0101

The image formation system is the core of the machine, and consists of a cartridge, transfer charging roller, and fixing assembly.

When a print command arrives from the video controller, the engine controller drives the main motor in response, thus turning on the photosensitive drum, developing cylinder, primary charging roller, transfer charging roller, and pressure roller.

Thereafter, the primary charging roller charges the surface of the photosensitive drum to a uniform negative potential; then, the machine scans a laser beam that has been modulated by video signals (VDO, /VDO) across the surface of the photosensitive drum to form a latent image.

When a latent image has been formed on the surface of the photosensitive drum, the developing cylinder turns it into a visible image using toner, and then the transfer charging roller moves it to print paper. The toner image is then fused permanently into the fibers of the print paper by the work of heat and pressure inside the fixing assembly.

When all is done, the cleaning blade scrapes the residual toner off the surface of the photosensitive drum for collection as waste toner. The primary charging roller once again charges the surface of the photosensitive drum to a uniform potential for the formation of the next image.

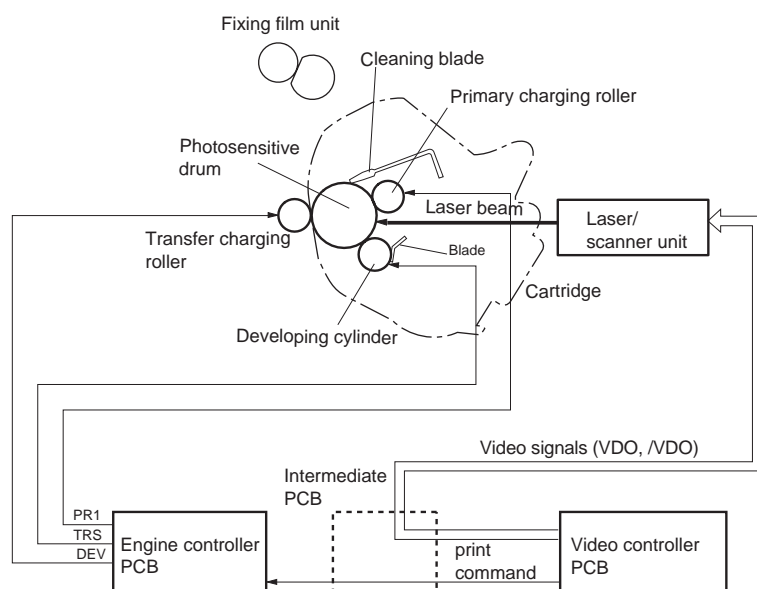

F-2-5

2.4.1.2 Printing Process

0008-0102

The machine's printing process consists of 5 major blocks and 7 sequential steps at the end of which a toner image is formed on print paper.

The following shows these blocks and steps with reference to a diagram indicating the relationship among individual steps:

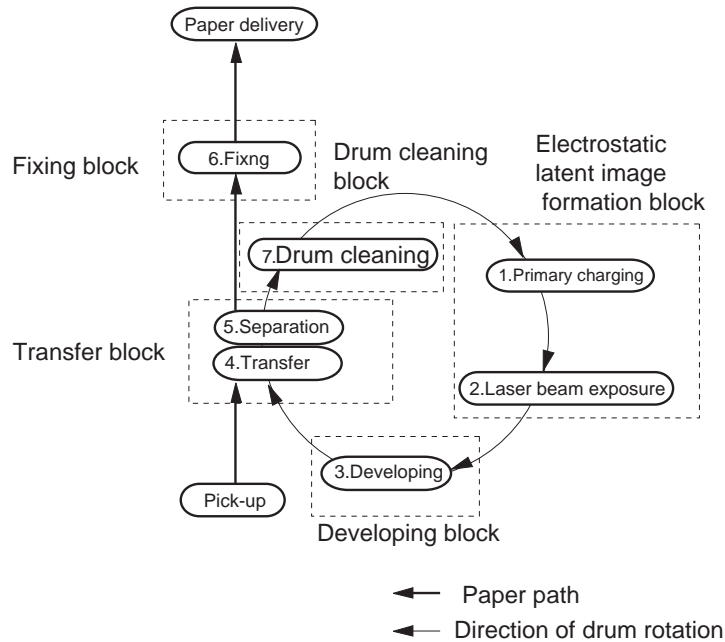

F-2-6

Latent Image Formation Block

In this block, a latent static image is formed on the surface of the photosensitive drum.

step 1: primary charging, in which the surface of the photosensitive drum is charged to a uniform negative potential.

step 2: laser beam exposure, in which a latent static image is formed on the surface of the photosensitive drum.

2. Development Block

In this block, toner is deposited on the static image formed on the surface of the photosensitive drum, thus turning it into a visible image.

step 3: development

3. Transfer Block

In this block, the toner image on the surface of the photosensitive drum is moved to print paper.

step 4: transfer, in which the toner image is moved from the surface of the photosensitive drum to print paper.

step 5: separation, in which the print paper is detached from the photosensitive drum.

4. Fixing Block

In this block, the toner image is permanently fused to the print paper.

step 6: fixing

5. Drum Cleaning Block

In this block, the residual toner left on the photosensitive drum is removed for collection as waste toner.

step 7: drum cleaning, in which residual toner is removed from the photosensitive drum.

2.4.1.3 Latent Image Formation Block

0008-0103

This block consists of 2 steps during which a static image is formed on the surface of the photosensitive drum.

At the end of the last step in this block, the area of the drum surface not exposed by the laser beam retains negative charges (dark area), while the area exposed to the beam is rid of negative charges (light area).

The drum image formed by negative charges in this way is not visible to the human eye, hence the name "latent image."

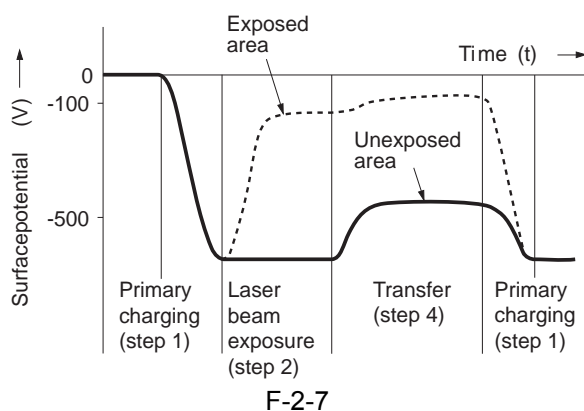

step 1: primary charging

In this step, the surface of the photosensitive drum is charged to a uniform negative potential by way of preparing it for the formation of a static image. The machine uses a method in which charges are directly applied to the surface of its photosensitive drum.

The primary charging roller is made of conducting rubber, and is given an AC bias in addition to a DC bias to ensure that the surface potential of the photosensitive drum remains uniform.

The DC bias is made to vary in keeping with the developing DC bias, which is varied according to the image density signal coming from the video controller.

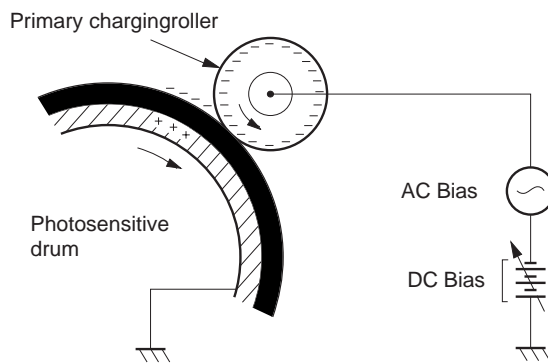

F-2-8

step 2: laser beam exposure

In this step, a static image is formed on the surface of the photosensitive drum.

When the machine scans the surface of the photosensitive drum that has been charged to a negative potential by means of a laser beam, the charges in the "light" area become neutralized, thus removing the negative potential of the drum surface and turning the area into a latent image.

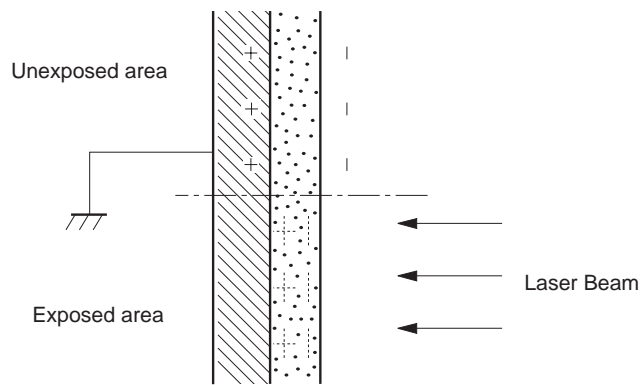

F-2-9

2.4.1.4 Development Block

0008-0104

In this block, toner is deposited on the static image formed on the surface of the photosensitive drum, turning it into a visible image. The machine uses a toner projection method for development, and the toner is a single-component toner.

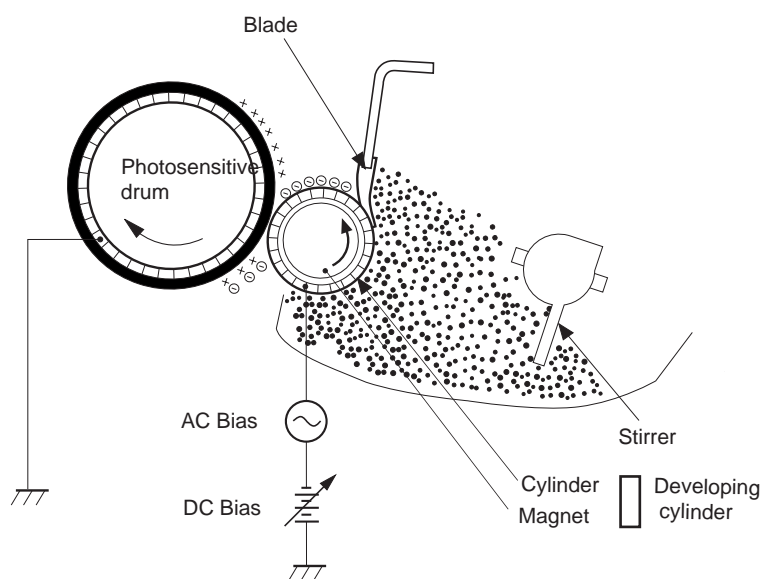

F-2-10

step 3: development

This is where toner is put over the static image formed on the surface of the photosensitive drum.

As shown in the figure, the developing assembly is made up of a developing cylinder (which in turn consists of a fixed magnet and a cylinder that rotates around it) and a rubber blade. It also holds toner inside it.

The toner is composed of magnetite and resins, and is held to the cylinder by means of magnetic force. The toner possesses insulating properties and is charged to a negative potential as the result of friction against a rotating cylinder.

The potential of the area of the photosensitive drum that has been exposed by a laser beam is higher than that of the negatively charged toner on the cylinder; thus, when the area comes close to the layer of the toner (possessing a negative potential) on the cylinder, the difference in potential between the drum surface and the cylinder will cause the toner to move to the drum surface, turning the static image on the drum surface into a visible image.

2.4.1.5 Transfer Block

0008-0106

This block consists of 2 steps which are used to move the toner image on the surface of the photosensitive drum to print paper.

Step 4: Transfer

In this step, a positive charge is applied to the back of print paper to attract toner from the surface of the photosensitive drum.

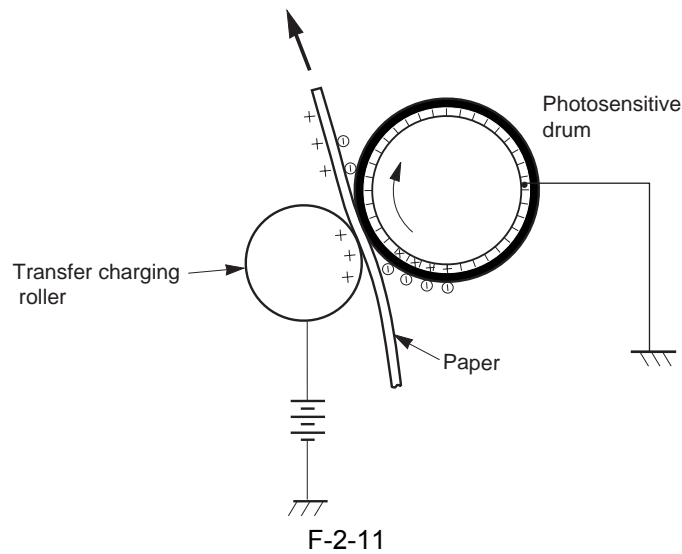

step 5: separation

In this step, the machine takes advantage of the rigidity of print paper to detach it from the photosensitive drum. The static eliminator serves to decrease the charge on the back of print paper, thus weakening the static bond of paper and facilitating the separation.

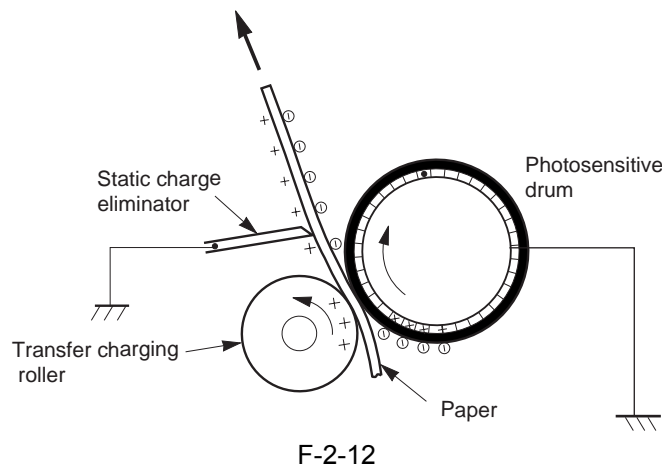

2.4.1.6 Fixing Block

0008-0107

The toner image moved to print paper in the transfer block is merely held to the print paper by the work of static charges, and can easily be disturbed by contact with a hand, for example.

In this block, the print paper and the toner image are subjected to pressure and heat so that the toner will be fused with the fibers of the paper to form a permanent image.

step 8: fixing

The machine uses an on-demand method of fixing, which is characterized by a low thermal capacity. The fact also

has enabled the machine to warm up quickly; moreover, the heater need not be supplied with power during standby. A short wait time and power consumption are two characteristics of an on-demand fixing method. The machine keeps the potential of the fixing film lower than that of the pressure roller, which makes the negatively charged toner on print paper more repellent and not tending to stick to the fixing film.

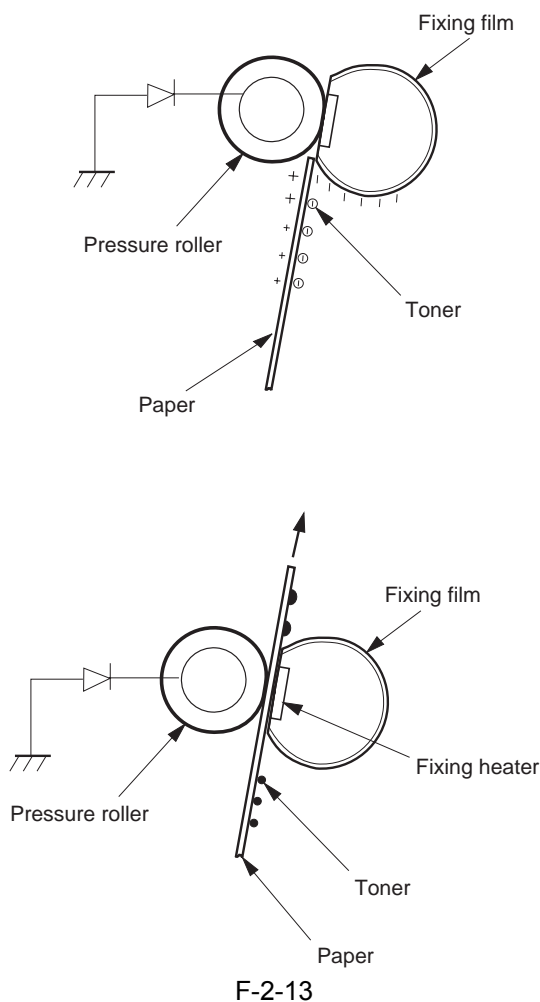

F-2-13

2.4.1.7 Drum Cleaning Block

0008-0108

In this block, the machine uses a cleaning blade to remove the toner left behind on the surface of the photosensitive drum for collection to the waste toner case, thus cleaning the drum and making it ready for the next cycle.

step 7: drum cleaning

In this step, the surface of the photosensitive drum is rid of residual toner for the next cycle of printing. The residual toner is scraped off by means of a cleaning blade, and the removed toner is collected in the waste toner case.

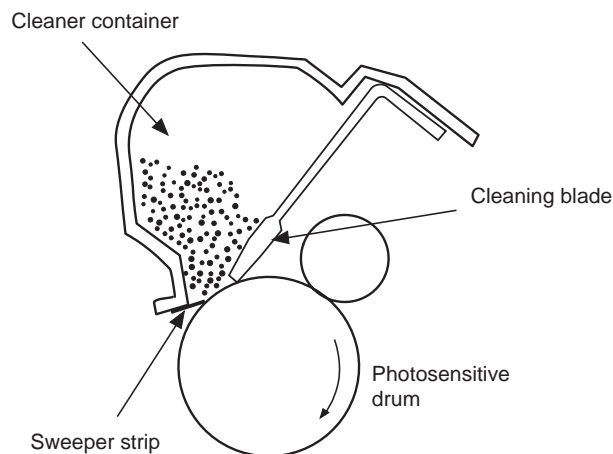

F-2-14

2.4.2 High-Voltage Control

2.4.2.1 Outline

0008-0111

The high-voltage control circuitry is a circuit needed for the formation of images, and consists of a primary charging bias circuit, developing bias circuit, and transfer charging bias circuit.

The primary charging bias circuit generates negative DC voltage and AC voltage, and applies a voltage consisting of these components to the primary charging roller.

The developing bias circuit generates a negative DC voltage and an AC voltage, and applies a voltage consisting of these voltage components to the developing cylinder.

The transfer charging bias circuit, on the other hand, generate a positive or negative DC voltage, and applies a positive or negative DC voltage to the transfer charging roller.

These circuits are controlled by commands from the CPU (IC902) of the engine controller, and they may be described as follows:

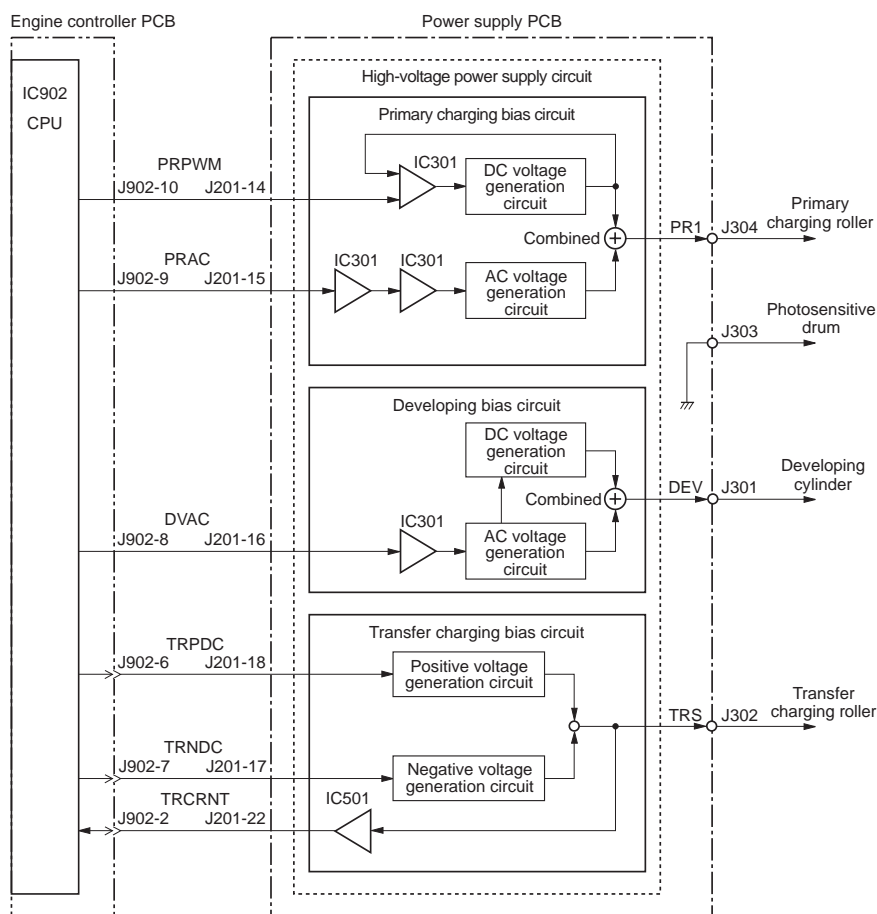

F-2-15

2.4.2.2 Generation of the Primary Charging Bias

0008-0113

The primary charging bias (PR1) is used to charge the surface of the photosensitive drum to a negative potential by way of preparing the surface for the formation of images.

The primary charging bias may be a primary charging DC negative bias generated by the primary charging bias generation circuit of the high-voltage power supply circuit or a primary charging AC bias. The level of the bias that consists of these 2 types of biases is changed in relation to the developing DC negative bias according to the image density information coming from the video controller.

2.4.2.3 Generation of the Developing Bias

0008-0115

The developing bias (DEV) is used to attract toner to the static (latent) image formed on the surface of the photosensitive drum. The developing bias may be a developing DC negative bias generated by the developing bias generation circuit of the high-voltage power supply circuit or a developing AC bias. A bias that consists of these 2 types of biases is applied to the developing cylinder of the cartridge at such times as programmed in advance.

The level of the developing negative bias is varied in relation to the primary charging DC negative bias according to the image density information arriving from the video controller.

2.4.2.4 Generation of the Transfer Charging Bias

0008-0117

The transfer charging bias (TRS) is used to transfer toner from the surface of the photosensitive drum to print paper. The transfer charging bias may be a transfer charging DC positive bias generated by the transfer charging bias generation circuit of the high-voltage power supply circuit)or a transfer charging DC negative bias). The transfer charging DC positive bias is applied to the transfer charging roller at time of toner transfer; on the other hand, the transfer charging DC negative bias is applied to the transfer charging roller at such times as when the roller needs to be cleaned.

The transfer charging bias generation circuit serves to apply the transfer charging biases to the transfer charging roller in keeping with the selected sequence of printing operation.

The following shows the type of bias applied for a specific printing sequence:

*** Printing Bias**

It is a transfer charging DC positive bias used to move the toner from the surface of the photosensitive drum to print paper during printing sequence.

*** Sheet-to-Sheet Bias**

It is a low level transfer charging DC positive bias applied to the transfer charging roller to prevent adhesion of toner remaining on the surface of the photosensitive drum to the transfer charging roller.

*** Cleaning Bias**

It is a bias used to return the residual toner sticking to the transfer charging roller at time of warm-up or last rotation to the surface of the photosensitive drum. This bias is a transfer charging DC negative bias, and is applied to the toner charging roller.

The level of the transfer charging DC positive bias is varied according to the instructions from the engine controller. The machine performs constant current control by charging the voltage level of the transfer charging DC positive bias according to the transfer current feedback signal (TRCRNT).

2.4.3 Toner Cartridge

2.4.3.1 Checking the Presence/Absence of a Toner Cartridge

0009-6874

The machine uses the paper width sensor (PS802) mound on its top of paper/paper width sensor PCB to detect the presence/absence of a toner cartridge.

When the power is turned on or the upper cover is opened and closed, the toner cartridge detecting lever goes on in response to the insertion of a toner cartridge, causing the output of PS802 to change and, as a result, the machine to detect the presence of a cartridge.

In the presence of a cartridge, the output of PS802 goes Low; in the absence of a cartridge, on the other hand, it will be High.

The sensor is also used to detect the width of paper in the course of a print job. When a sheet other than of a small

size (i.e., 197 mm or more in width) moves past, the paper width detecting lever operates, causing the output of PS802 to change and, thus, enabling the machine to check the width of the sheet.

In the case of a small-size sheet, the output of PS802 will be High; otherwise, it will be Low.

The following describes the relationship between the sensor output and the flag position:

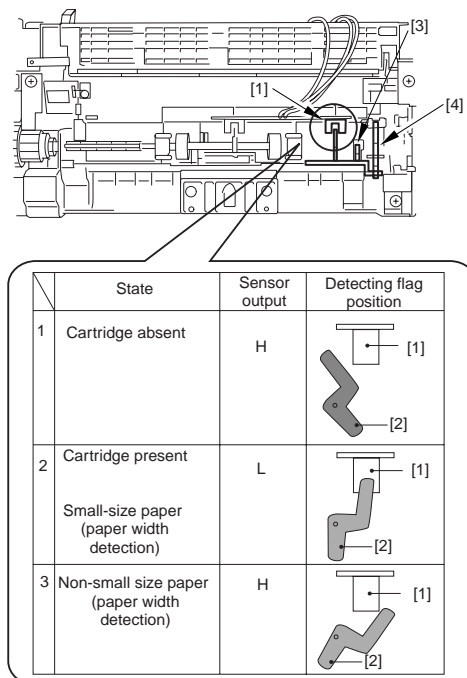

F-2-16

[1] PS802

[2] Flag

[3] Toner cartridge detecting lever

[4] Paper width detecting lever

2.4.3.2 Checking the Level of Toner

0009-6875

The machine does not have a mechanism to check the level of remaining toner.

2.5 PICKUP AND FEEDING SYSTEM

2.5.1 Overview/Configuration

2.5.1.1 Outline

0008-0146

The pickup/feed system serves to pick up and move print paper, and consists of the main motor, solenoid, and various rollers.

The machine is designed to pick up paper from 2 sources: pickup tray and manual feed tray; delivery, on the other hand, must be to the face-down tray.

The machine uses the same pickup roller to pick up paper, regardless of whether the paper is placed in the pickup tray or the manual feed tray. After pickup, the paper is moved to the photosensitive drum and the transfer charging roller, the fixing film unit and the pressure roller, and the face-down delivery roller in sequence to reach the face-down tray for delivery.

The paper path is equipped with 2 photointerrupters: paper leading edge sensor (PS801) and delivery sensor (PS803), enabling the machine to find out whether print paper has reached or has moved past a specific point of the paper path. If print paper fails to reach or move past a specific point within a specific period of time, the CPU of the engine controller will identify the condition as being a jam, and communicate the fact to the video controller.

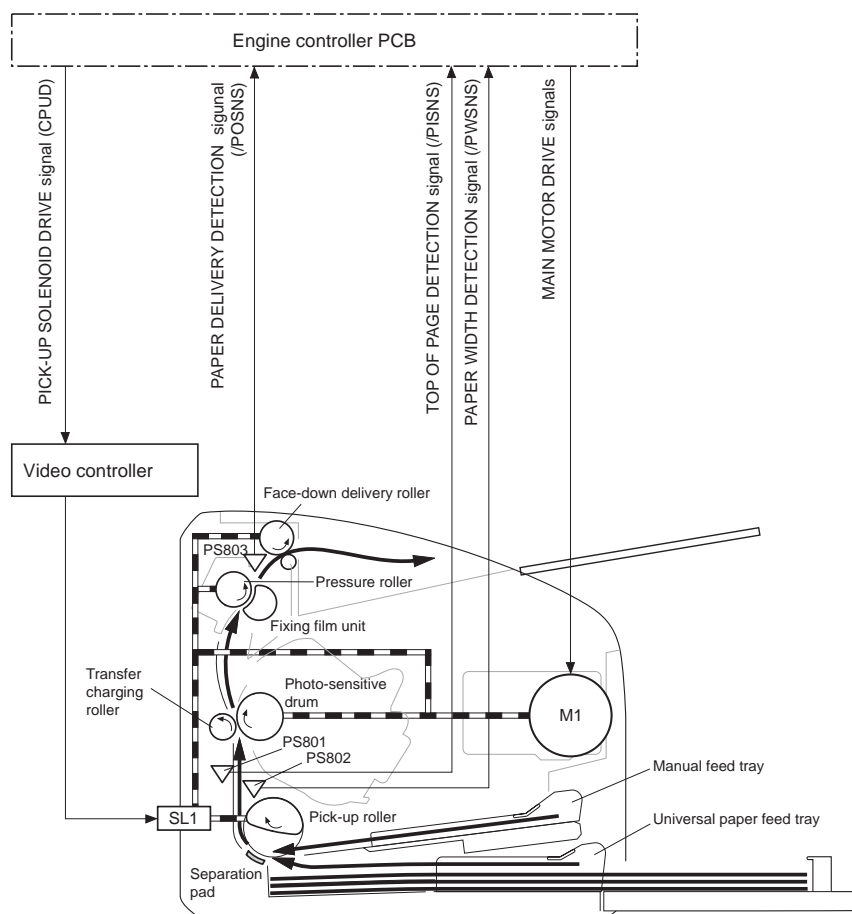

F-2-17

PS801: paper leading edge sensor

PS802: paper width sensor

PS803: delivery sensor

M1: main motor

SL1: pickup solenoid

2.5.2 Detecting Jams

2.5.2.1 Jam Detection Outline

2.5.2.1.1 Outline

0008-0148

The machine uses the following sensors to check the presence/absence of paper and to find out whether paper is moving normally:

- * paper leading edge sensor (PS801)
- * paper width sensor (PS802)

* delivery sensor (PS803)

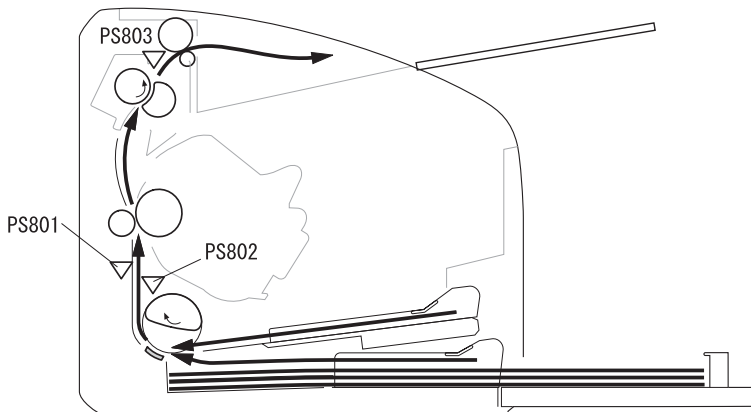

F-2-18

The machine checks for a jam with reference to the presence/absence of paper at a specific sensor at such times as programmed in advance.

When the CPU detects a jam, it will suspend the ongoing printing operation and communicate the fact to the video controller.

2.5.2.2 Delay Jams

2.5.2.2.1 Pickup Delay Jam

0008-0153

The machine uses a retry mechanism in which it executes pickup operation twice for detection of a pickup delay jam caused by a pickup fault.

The CPU executes pickup operation twice if the paper leading edge sensor (PS801) does not detect the leading edge of print paper within about 1.4 sec after the pickup solenoid (SL1) goes on.

Thereafter, if the paper leading edge sensor (PS801) does not detect the leading edge of print paper within about 1.4 sec, the machine will assume the condition to indicate a pickup delay jam.

2.5.2.2.2 Delivery Delay Jam

0008-0156

The CPU will assume the presence of a delivery delay jam if the delivery sensor (PS803) does not detect the leading edge of print paper about 1.8 sec after the paper leading edge sensor (PS801) has detected the leading edge of print paper.

2.5.2.3 Stationary Jams

2.5.2.3.1 Pickup Stationary Jam

0008-0155

The CPU will detect the presence of a pickup stationary jam if the trailing edge of print paper is not detected about 4.6 sec after the paper leading edge sensor (PS801) has detected the leading edge of print paper.

Moreover, it will also assume the presence of a pickup stationary jam if the paper width sensor (PS802) does not detect the trailing edge of paper within 200 msec after the paper width sensor (PS802) has detected the leading edge of paper and the paper leading edge sensor (PS801) has detected the trailing edge of paper.

2.5.2.3.2 Delivery Stationary Jam

0008-0157

The CPU will assume the presence of a delivery stationary jam if the delivery sensor (PS803) does not detect the leading edge of print paper during a period of about 2.0 sec after the paper leading edge sensor (PS801) has detected the trailing edge of print paper.

2.5.2.4 Other Jams

2.5.2.4.1 Wrapping Jam Around the Fixing Assembly

0008-0158

The CPU will assume that paper has wrapped around the fixing assembly if the delivery sensor (PS803) does not detect the trailing edge of paper within about 1.3 sec after the delivery sensor (PS803) has detected the leading edge of print paper and then about 1.3 sec after the paper leading edge sensor (PS801) has detected the leading edge of print paper.

2.5.2.4.2 Residual Jam at Start-Up

0008-0159

The CPU will identify a residual jam when the paper leading edge sensor (PS801) or the delivery sensor (PS803) detects print paper at the start of initial rotation.

2.5.2.4.3 Door Open Jam

0008-0161

The CPU will identify a door open jam if the leading edge sensor (PS801) or the delivery sensor (PS803) detects print paper when the door is identified as being open.

2.5.3 Multi-purpose Pickup

2.5.3.1 Pickup from the Pickup Tray/Manual Feed Tray

0008-0168

When paper is picked up from either the pickup tray or the manual feed tray, the machine makes sure that no more than a single sheet of paper is picked up from the source.

If paper is found in both trays, the machine uses the manual feed tray as the source of paper. The machine operates as follows to pick up paper from the pickup tray/manual feed tray:

1. The engine controller turns on the main motor (M1) immediately after it receives the print command from the video controller. In response, the rollers other than the pickup roller start to rotate.
2. When the initial rotation ready state (Note) starts, the pickup solenoid (SL1) goes on for about 0.2 sec, causing the rotation of the main motor to rotate the pickup roller.
3. The pickup cam starts to rotate in keeping with the rotation of the pickup roller. The shape of the cam causes the spring to push up the holding plate. The paper on the holding plate is picked up by the work of the pickup roller.
4. The engine controller sends the laser beam detection signal (/BD) to the video controller a specific period of time after the leading edge sensor (PS801) detects the leading edge of print paper that has been picked up.
5. The video controller sends video signals to the laser/scanner assembly based on the /BD signal so as to form an image on the surface of the photosensitive drum, making sure that the leading edge of the image and the leading edge of the print paper will match.
6. The print paper is then moved to the face-down tray for delivery by the work of the pressure roller and the face-down delivery roller.



When the initial rotation ready state:

The machine is in an initial rotation ready state when the main motor is on and, in addition, the fixing assembly temperature has reached a specific level and the scanner motor has reached a specific revolution.

2.6 EXTERNAL AND CONTROLS SYSTEM

2.6.1 Power Supply

2.6.1.1 Power Supply

2.6.1.1.1 Low-Voltage Power Supply Circuit

0008-0490

The low-voltage power supply circuit serves to convert the AC power from the power inlet into DC power for supply to various loads. The AC power is supplied to the low-voltage power supply circuit on the power supply PCB when the power switch (SW101) is turned on. The AC power is then converted by the printer unit into +24 V, which will then be converted into +5 V and +3.3 V in the engine controller.

The +24 V power is used to drive the main motor, scanner motor, and solenoids, while the +5 V power is used to drive the sensors and the ICs on the video controller PCB.

The +24 V power turns to +24 V when it moves through the door switch (SW301) to reach the high-voltage power supply circuit. The +24 VU also serves as the door open detection signal (DOSNS), enabling the CPU find out whether the door is open or not.

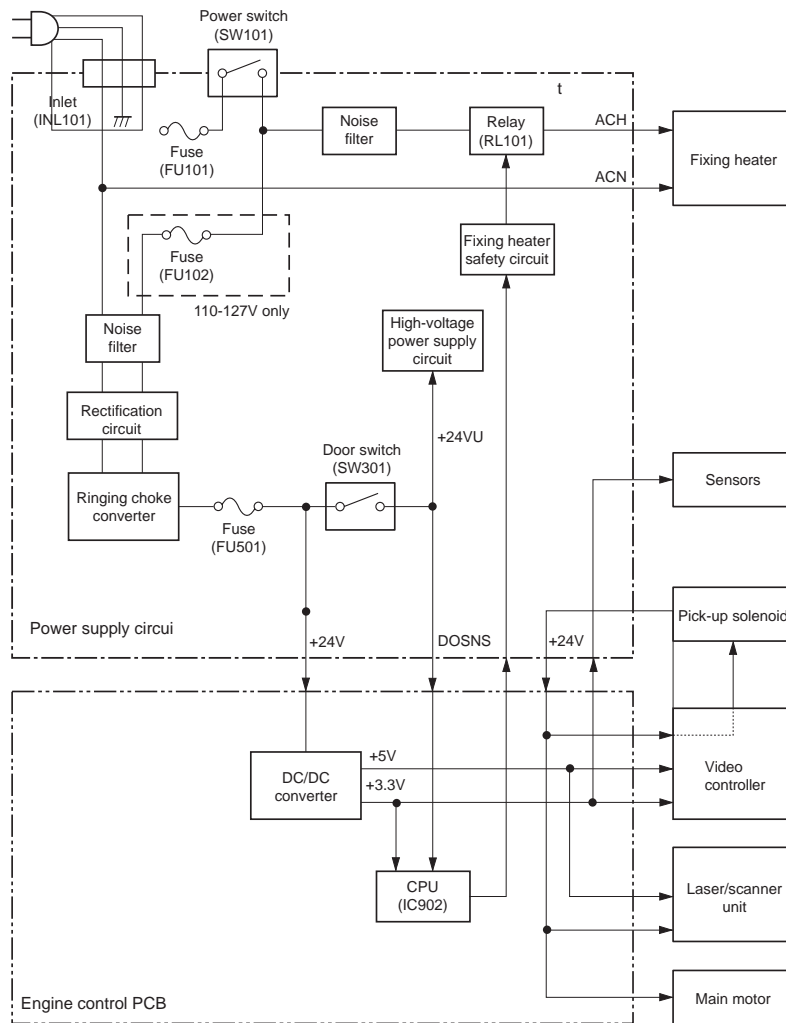

F-2-19

2.6.1.2 Protective Functions

2.6.1.2.1 Protective Mechanisms

0008-0493

The protective mechanisms include an overcurrent protective circuit that uses a fuse. If short circuit or the like occurs because of some fault and, as a result, an overcurrent flows, the fuses will melt to cut off the power to the power supply circuit.

The power supply circuit is equipped with 2 fuses (Note; FU101, FU102); in the event an overcurrent flows into the AC line, either of these fuses will melt to cut out the current. The power supply circuit also uses another fuse (FU501) to cut out the output voltage in response to an overcurrent in the DC line.

If the overcurrent protective circuit has gone on and DC voltage stops from the power supply circuit, turn off the power switch (SW101), correct the fault in the load, replace the fuse, and turn the power switch back on.



The fuse FU102 is used only in the 110/127 V model.

2.7 ENGINE CONTROL SYSTEM

2.7.1 Video Controller

2.7.1.1 Overview

0008-0510

The video controller receives print information from an external device (e.g., host computer) through an interface cable. The print information includes the CAPT command used to communicate printer status and unique information and dot data, which is the result of conversion of resource type print data by the host computer. The dot data is sent to the engine controller for control of the activation of the laser diode.

The external device can check the status of the printer unit by means of a bi-directional interface.

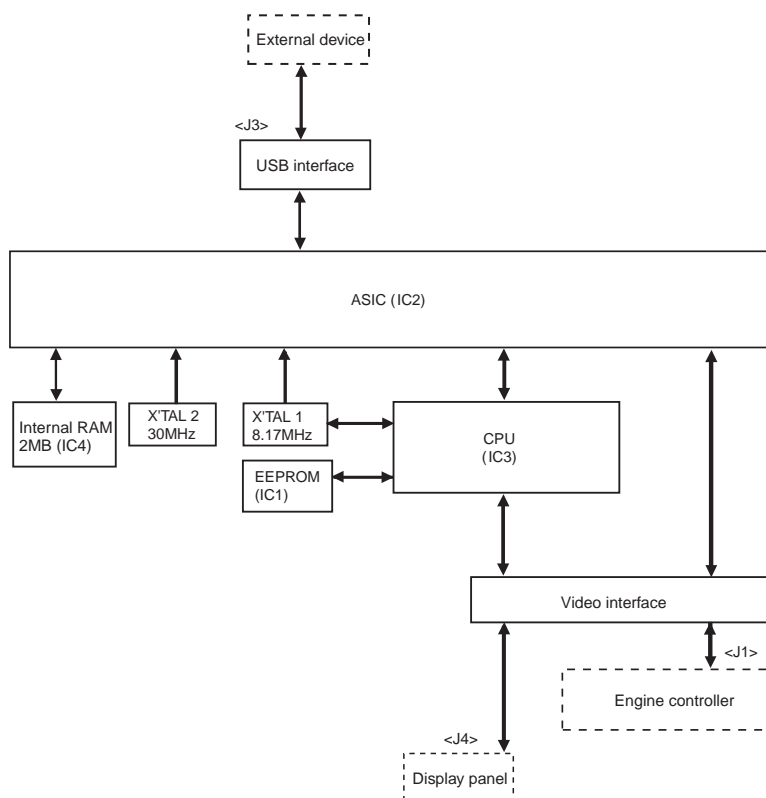

F-2-20

2.7.1.2 Outline of Operation by Block

0008-0552

1. EEPROM (IC1)

It possesses 128 bytes of memory, permitting writing of data and erasing of it electrically. It is used to retain parameters of the printer unit that must remain unchanged (e.g., USB serial number, printing environment; these

parameters are retained when the power is turned off/on).

2. ASIC (IC2)

It has the following functions:

1. controls the input/output of the internal RAM.
2. controls the timing at which dot pattern data is sent to the engine controller.
3. decompresses the image data that has been compressed.

3. CPU (IC3)

It has the following functions:

1. processes the serial commands of the video interface.
2. transmits and receives the CAPT command through the USB interface.
3. controls the display panel interface.

4. DRAM (IC4)

It possesses 2 MB of memory, and has the following function:

1. temporarily retains the dot data (reception buffer) that has been converted from image data.

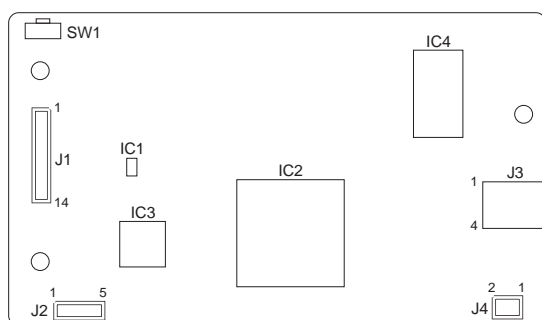

F-2-21

2.7.2 Engine Controller

2.7.2.1 Outline

0008-0558

The engine controller circuit is used to control the sequence of operation of the machine, and it operates under the control of the CPU found in the engine controller.

When the machine is turned on and the power supply supplies the engine controller with DC power, the CPU starts to control the operation of the printer. When the machine is in a standby state, the CPU then drives the various loads (e.g., laser diode, motor, solenoid) according to the print command coming from the video controller.

The following is a block diagram of the circuit:

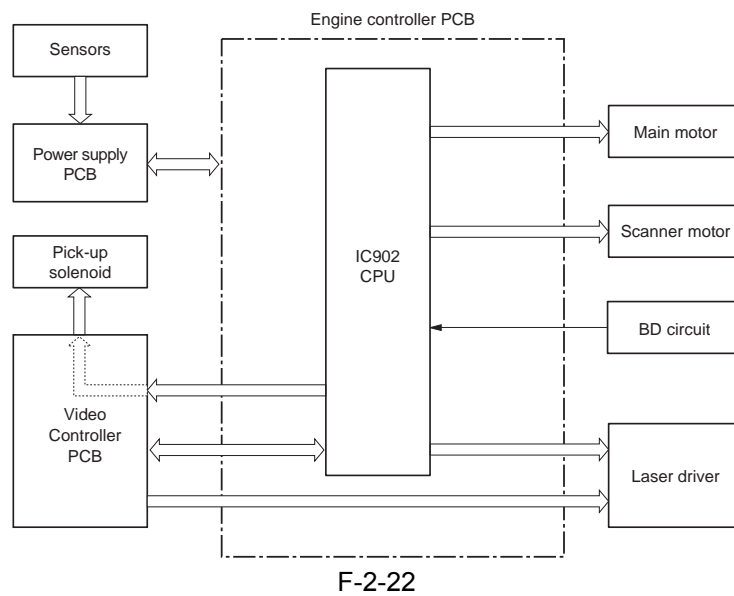

*** CPU (IC902)**

The CPU is a 8-bit single-chip microprocessor IC. The CPU is equipped with both ROM and RAM, and it performs the following as instructed by the control program stored in the ROM:

1. sequential control of the printer.
2. communicates with the interface controller.
3. controls the power supply circuit.
4. controls the laser/scanner.
5. controls sensors.
6. controls loads (motor, solenoid)
7. detects the presence/absence of a cartridge

2.8 FIXING UNIT/DELIVERY SYSTEM

2.8.1 Overview/Configuration

2.8.1.1 Overview

0008-0451

The fixing/delivery system consists of the fixing film unit, pressure roller, face-down delivery roller, and the like. Its rollers are driven by the main motor (M1).

When print paper carrying a toner image arrives in the fixing assembly, the machine uses the heat from the fixing heater and the pressure from the pressure roller to permanently fuse the toner with the fibers of the print paper before it moves out of the fixing assembly.

Once outside the fixing assembly, the print paper is delivered to the delivery tray by the work of the face-down delivery roller upon detection by the delivery sensor (PS803).

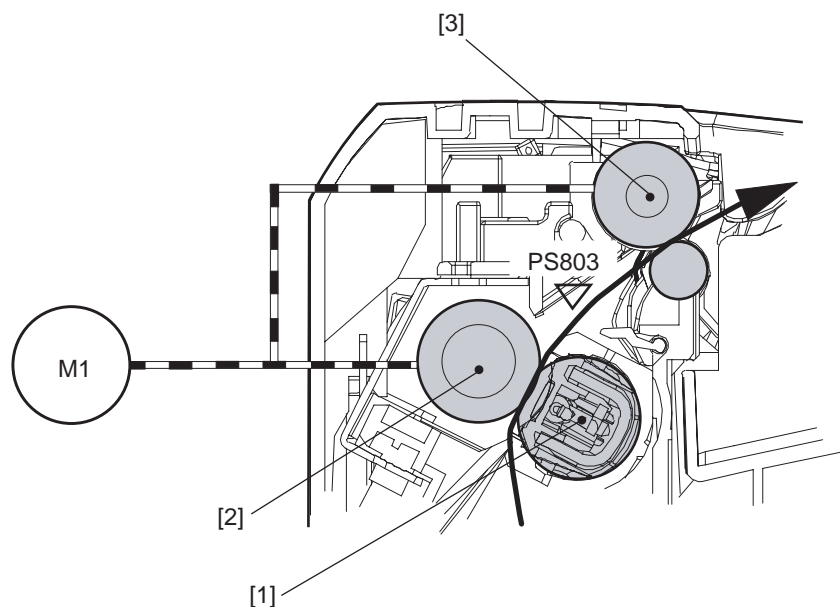

F-2-23

T-2-3

Name

[1] Fixing film unit	PS803 delivery sensor
[2] Pressure roller	M1 main motor
[3] Face-down delivery roller	

2.8.1.2 Major Components of the Fixing Assembly

0008-0914

The fixing assembly consists of the following major components possessing the functions described:

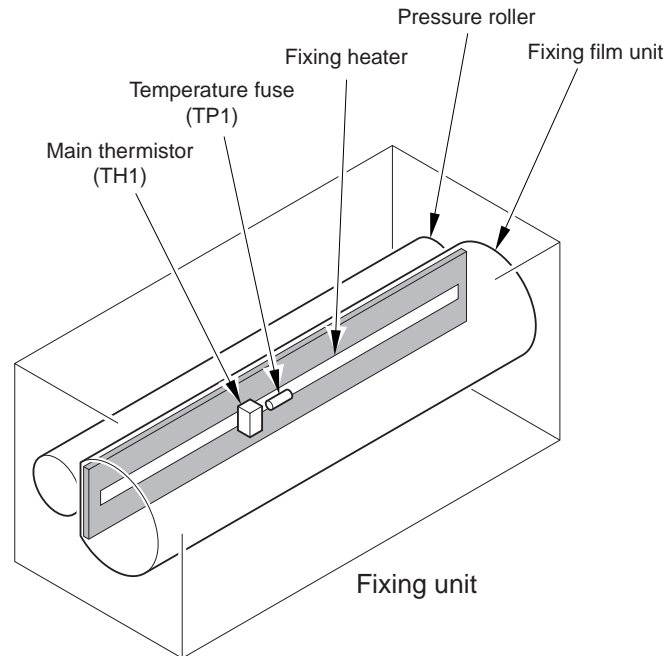

F-2-24

T-2-4

- Heater:** There is a single heater (fixing heater; H1) used to heat the fixing film (ceramic heater).
- Thermistor:** There is a single thermistor (main thermistor; TH1) used for the control of the temperature of the fixing heater (non-contact thermistor).
- Thermal fuse:** There is a single thermal fuse (thermal fuse; TP1) used to detect overheating of the fixing heater (non-contact fuse). The thermal fuse is designed to melt in response to overheating of the heater, thus cutting off the power to the heater.

2.8.2 Various Control Mechanisms

2.8.2.1 Fixing Temperature Control

2.8.2.1.1 Heater Temperature Control

0008-0379

The heater temperature control mechanism consists in monitoring the surface temperature of the fixing heater and controlling the fixing heater drive signal so that the temperature of the fixing heater is identical to the target temperature.

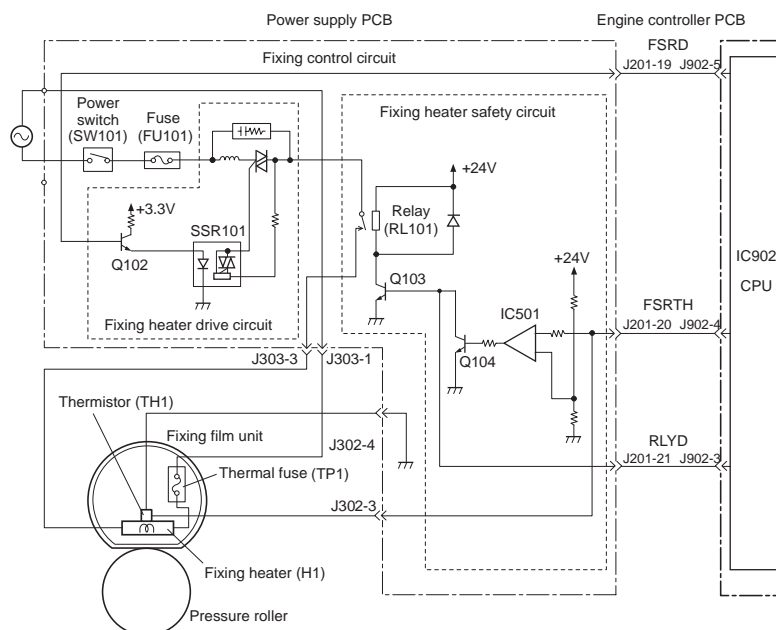

F-2-25

The surface temperature of the fixing heater is monitored by the thermistor (TH1) that remains in contact with the fixing heater. The resistance of the thermistor decreases in response to increases in the surface temperature of the fixing heater, causing the voltage of the fixing heater temperature detection single (FSRTH) to change.

The CPU (IC902) found inside the engine controller monitors the signal (FSRTH), and generates the fixing heater drive signal (FSRD) according to the voltage of the signal operating in conjunction with the CPU. The fixing heater drive circuit, on the other hand, uses the signal to control the fixing heater so that the temperature of the fixing heater remains at a specific level.

The machine executes the following 4 control mechanisms according to the temperature of the fixing heater and the size of the selected paper:

1. start-up temperature control; from when the print command arrives at the engine control to when the fixing heater reaches the target temperature.
2. paper passage temperature control; during printing so that the temperature of the fixing heater is identical the target temperature.

The target temperature may be any of 5 settings, used according to the selected fixing mode. Any of these modes is selected according to the settings of the driver and such parameters as paper size and the number of printouts.

The following shows the relationship between the paper type setting and the fixing mode in relation to the fixing target temperature:

T-2-5

Paper type selected for driver	Fixing mode	Fixing target temperature
Plain paper	Normal	165 to 175 deg C
Heavy paper	Rough	180 to 190 deg C
Heavy paper H	Extra	180 deg C
Transparency, plain paper L	Local	150 deg C
Envelope	Envelope	165 to 175 deg C

3. sheet-to-sheet temperature control; between sheets during continuous printing so that the temperature of the fixing heater is lower than the target temperature, thus preventing overheating of the fixing film.

4. down sequence; during continuous printing so as to prevent overheating of the edges of the heater.

In this control, the CPU of the engine controller checks the length and width of paper; if the size of the paper matches a specific set of conditions, the machine is shifted to long narrow mode (Note) or small paper mode regardless of the settings of the driver.

In this mode, the CPU forces the printing speed to decrease conversely increasing the distance between sheets, thereby increasing the sensitivity of the thermistor located in the middle of the fixing heater and, consequently, preventing the edges of the heater from overheating.

The following shows the relationship between the printing speed and the conditions used to make a shift to this mode:

T-2-6

Down-sequence mode	Paper length	Paper width	Printing speed (ppm)
No down sequence (normal state)	267.4 mm or more	197 mm or more	Number of printouts according to paper size
Small size paper mode	267.4 mm or less	197 mm or less	8-->6-->4
Long narrow paper mode	267.4 mm or more	197 mm or less	3



The term "long narrow paper" refers to a type of paper that is narrow in width and long in length.

2.8.2.2 Protective Functions

2.8.2.2.1 Protective Mechanisms

0008-0380

The machine is equipped with a protective mechanism in which the power to the heater is cut off upon detection of overheating of the fixing heater; the mechanism used may be any of the following 3:

1. protection by means of the CPU
2. protection by means of the fixing heater safety circuit
3. protection by means of a thermal fuse

Specifically, these protective mechanisms operate as follows:

1. Protection by the CPU

The CPU monitors the voltage of the fixing heater temperature detection signal (FSRTH) from the thermistor at all times; if the fixing temperature appreciably exceeds a specific level, it cuts off the power to the fixing heater.

In the event that the temperature of the fixing heater appreciably increases and the voltage of FSRTH is about 0.85 V or less (equivalent of 230 deg C) for 150 msec or if the level is about 1.17 V or less for 5 sec, the CPU causes the fixing heater drive signal (FSRD) to go Low to turn off the photo triac coupler (SSR101), thus cutting off the power to the fixing heater.

2. Protection by the Fixing Heater Safety Circuit

The fixing heater safety circuit monitors the voltage of the fixing heater temperature signal (FSRTH) from the thermistor at all times; if the fixing temperature appreciably exceeds a specific level, it cuts off the power to the fixing heater regardless of the instructions of the CPU.

In the event that the temperature of the fixing heater abnormally increases and the voltage of the fixing heater temperature detection signal (FSRTH) of the thermistor is about 0.57 V or less (equivalent of 265 deg C), the output of the comparator (IC501) goes Low to turn off the transistor (Q103). The fact will cause the relay (RL101) to go off to cut off the power to the fixing heater regardless of the state of the relay drive signal (RLYD) from the CPU.

3. Protection by a Thermal Fuse

If the temperature of the fixing heater abnormally increase and the temperature of the thermal fuse (FU1) exceeds about 30 deg C, the thermal fuse will melt to cut of the power to the fixing heater.

2.8.2.2.2 Detection of a Fault

0008-0383

The CPU will assume the presence of a fault in the fixing assembly in response to any of the following 7 conditions; it will turn off the relay (RL101) to cut out the power to the heater and, at the same time, will communicate the fact to the video controller:

1. the temperature of the thermistor does not exceeded 50 deg C within 1.47 sec after the start of temperature control.
2. it monitors the temperature of the thermistor every 5 msec; if the temperature of the thermistor is 230 deg C or more 30 times continuously.
3. it monitors the temperature of the thermistor every 5 msec; if the temperature is 100 deg C or less at time of normal temperature control (or 5 deg C or less at time of cleaning mode) 240 times continuously.
4. after the temperature of the thermistor has exceeded 50 deg C, it monitors the temperature of the thermistor every

- 5 msec; if the temperature is less than 20 deg C 60 times continuously.
5. the temperature of the thermistor does not reach 100 deg C within 30 sec after supply of power to the fixing heater has started.
6. while the paper is retained by the fixing assembly, it monitors the temperature of the thermistor every 200 msec; if the temperature is 120 deg C or more 25 times continuously.
7. while the paper is retained in the fixing assembly; it monitors the temperature of the thermistor every 200 msec; if the temperature is less than 135 deg C 150 times continuously

Chapter 3 DISASSEMBLY AND ASSEMBLY

Contents

3.1 EXTERNAL AND CONTROLS SYSTEM	3-1
3.1.1 Rear Cover.....	3-1
3.1.1.1 Removing the Right Cover	3-1
3.1.1.2 Removing the Left Cover	3-2
3.1.1.3 Removing the Front Cover	3-2
3.1.1.4 Removing the Upper Cover	3-3
3.1.1.5 Removing the Rear Cover	3-4
3.1.2 Right Cover	3-5
3.1.2.1 Removing the Right Cover	3-5
3.1.3 Left Cover.....	3-6
3.1.3.1 Removing the Left Cover	3-6
3.1.4 Upper Cover	3-7
3.1.4.1 Removing the Right Cover	3-7
3.1.4.2 Removing the Left Cover	3-8
3.1.4.3 Removing the Front Cover	3-9
3.1.4.4 Removing the Upper Cover	3-9
3.1.5 Front Cover.....	3-11
3.1.5.1 Removing the Right Cover	3-11
3.1.5.2 Removing the Left Cover	3-12
3.1.5.3 Removing the Front Cover	3-13
3.1.6 Delivery Tray	3-13
3.1.6.1 Removing the Delivery Tray	3-13
3.1.7 Pickup Tray	3-14
3.1.7.1 Removing the Pickup Tray	3-14
3.1.8 Engine controller board	3-14
3.1.8.1 Removing the Right Cover	3-14
3.1.8.2 Removing the Left Cover	3-15
3.1.8.3 Removing the Front Cover	3-16
3.1.8.4 Removing the Engine Controller PCB	3-17
3.1.9 Video Controller Board	3-18
3.1.9.1 Removing the Right Cover	3-18
3.1.9.2 Removing the Video Controller PCB	3-19
3.1.10 Power supply board	3-20
3.1.10.1 Removing the Right Cover	3-20
3.1.10.2 Removing the Left Cover	3-21
3.1.10.3 Removing the Front Cover	3-22
3.1.10.4 Removing the Upper Cover	3-22
3.1.10.5 Removing the Rear Cover	3-24
3.1.10.6 Removing the Power Supply PCB	3-24
3.1.11 Top sensor	3-25
3.1.11.1 Removing the Right Cover	3-25
3.1.11.2 Removing the Left Cover	3-26
3.1.11.3 Removing the Front Cover	3-27
3.1.11.4 Removing the Upper Cover	3-28

3.1.11.5 Removing the Rear Cover.....	3-29
3.1.11.6 Removing the Paper Leading Edge/Paper Width Sensor PCB.....	3-30
3.2 LASER EXPOSURE SYSTEM.....	3-32
3.2.1 Laser Scanner Unit.....	3-32
3.2.1.1 Removing the Right Cover.....	3-32
3.2.1.2 Removing the Left Cover.....	3-33
3.2.1.3 Removing the Front Cover.....	3-33
3.2.1.4 Removing the Engine Controller PCB.....	3-34
3.2.1.5 Removing the Laser Scanner Unit.....	3-35
3.3 IMAGE FORMATION SYSTEM.....	3-37
3.3.1 Transfer Charging Roller.....	3-37
3.3.1.1 Removing the Transfer Charging Roller.....	3-37
3.4 PICKUP AND FEEDING SYSTEM.....	3-38
3.4.1 Pickup Unit.....	3-38
3.4.1.1 Removing the Transfer Charging Roller.....	3-38
3.4.1.2 Removing the Right Cover.....	3-38
3.4.1.3 Removing the Left Cover.....	3-39
3.4.1.4 Removing the Front Cover.....	3-40
3.4.1.5 Removing the Upper Cover.....	3-41
3.4.1.6 Removing the Rear Cover.....	3-42
3.4.1.7 Removing the Power Supply PCB.....	3-43
3.4.1.8 Removing the Fixing Assembly.....	3-44
3.4.1.9 Removing the Pickup Assembly.....	3-44
3.4.2 Manual Pickup Roller.....	3-45
3.4.2.1 Removing the Pickup Roller.....	3-45
3.4.3 Multi-purpose Pickup Solenoid.....	3-45
3.4.3.1 Removing the Right Cover.....	3-45
3.4.3.2 Removing the Pickup Solenoid.....	3-46
3.4.4 Manual Separation Pad.....	3-47
3.4.4.1 Removing the Separation Pad.....	3-47
3.4.5 Main Motor.....	3-47
3.4.5.1 Removing the Right Cover.....	3-47
3.4.5.2 Removing the Left Cover.....	3-48
3.4.5.3 Removing the Front Cover.....	3-49
3.4.5.4 Removing the Engine Controller PCB.....	3-49
3.4.5.5 Removing the Laser Scanner Unit.....	3-51
3.4.5.6 Removing the Main Motor.....	3-51
3.5 FIXING SYSTEM.....	3-53
3.5.1 Fixing Unit.....	3-53
3.5.1.1 Removing the Right Cover.....	3-53
3.5.1.2 Removing the Left Cover.....	3-54
3.5.1.3 Removing the Front Cover.....	3-54
3.5.1.4 Removing the Upper Cover.....	3-55
3.5.1.5 Removing the Rear Cover.....	3-56
3.5.1.6 Removing the Power Supply PCB.....	3-57
3.5.1.7 Removing the Fixing Assembly.....	3-58
3.5.2 Fixing Film Unit.....	3-58
3.5.2.1 Removing the Right Cover.....	3-58
3.5.2.2 Removing the Left Cover.....	3-59

3.5.2.3 Removing the Front Cover	3-60
3.5.2.4 Removing the Upper Cover	3-60
3.5.2.5 Removing the Rear Cover	3-62
3.5.2.6 Removing the Power Supply PCB	3-62
3.5.2.7 Removing the Fixing Assembly	3-63
3.5.2.8 Removing the Fixing Film Unit	3-64
3.5.3 Fixing Pressure Roller	3-64
3.5.3.1 Removing the Right Cover	3-64
3.5.3.2 Removing the Left Cover	3-65
3.5.3.3 Removing the Front Cover	3-66
3.5.3.4 Removing the Upper Cover	3-67
3.5.3.5 Removing the Rear Cover	3-68
3.5.3.6 Removing the Power Supply PCB	3-69
3.5.3.7 Removing the Fixing Assembly	3-70
3.5.3.8 Removing the Fixing Film Unit	3-70
3.5.3.9 Removing the Pressure Roller	3-71
3.5.4 Delivery Sensor	3-71
3.5.4.1 Removing the Right Cover	3-71
3.5.4.2 Removing the Left Cover	3-72
3.5.4.3 Removing the Front Cover	3-73
3.5.4.4 Removing the Upper Cover	3-74
3.5.4.5 Removing the Rear Cover	3-75
3.5.4.6 Removing the Delivery Sensor	3-76

3.1 EXTERNAL AND CONTROLS SYSTEM

3.1.1 Rear Cover

3.1.1.1 Removing the Right Cover

0008-3537

- 1) Open the delivery tray [1].
- 2) Open the upper cover [2].
- 3) Remove the screw [3].
- 4) Remove the 4 claws [4], and slide the right cover [5] in the direction of the arrow.

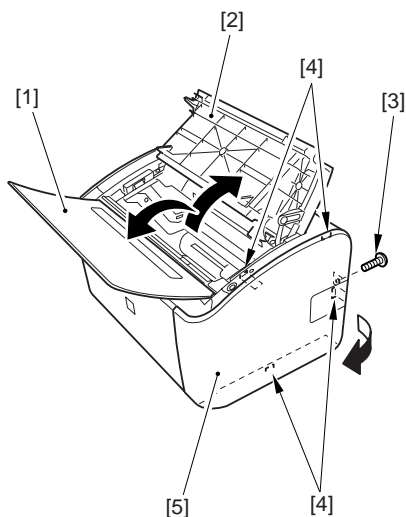

F-3-1

- 5) Remove the 3 claws [1], and slide the right cover [2] in the direction of the arrow to detach.

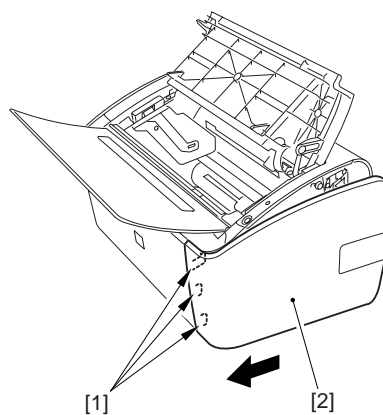

F-3-2

3.1.1.2 Removing the Left Cover

0008-3538

- 1) Open the delivery tray [1].
- 2) Open the upper cover [2].
- 3) Remove the screw [3].
- 4) Remove the 4 claws [4], and slide the left cover [5] in the direction of the arrow.

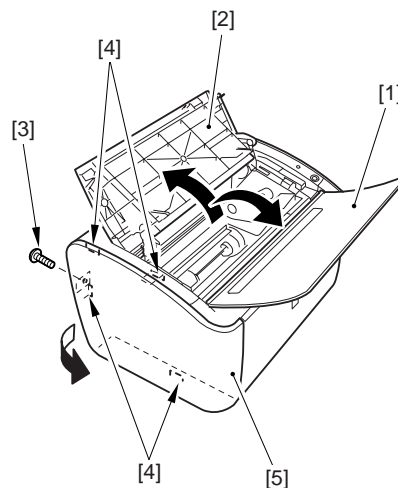

F-3-3

- 5) Remove the 3 claws [1], and slide the left cover [2] in the direction of the arrow to detach.

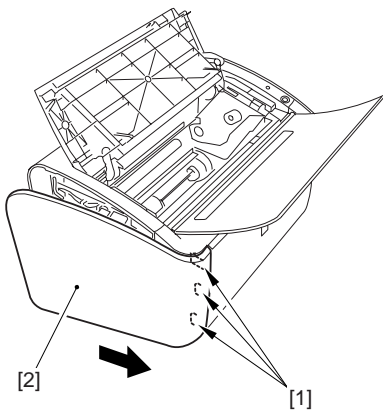

F-3-4

3.1.1.3 Removing the Front Cover

0008-3539

- 1) Remove the 2 claws [1].
- 2) Slide the front cover [2] in the direction of the arrow to detach.

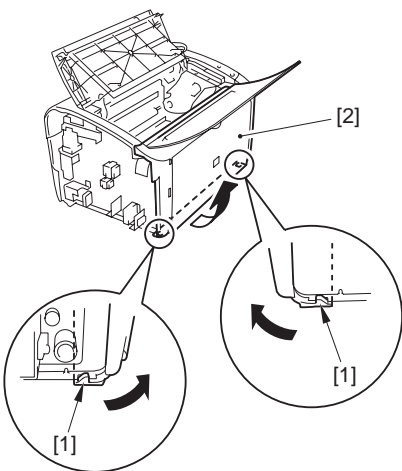

F-3-5

3.1.1.4 Removing the Upper Cover

0008-3540

- 1) Free the link stop [2] from the door link [1].
- 2) Remove the 2 screws [3].

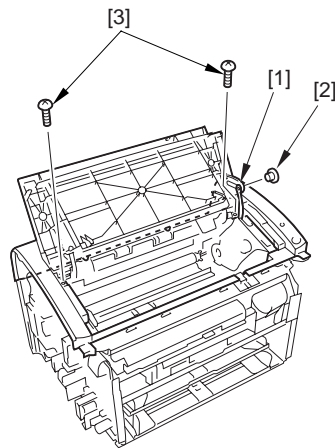

F-3-6

- 3) Slide the upper cover [1] in the direction of the arrow.
- 4) Remove the 2 claws [2] of the upper cover, and detach the cover.

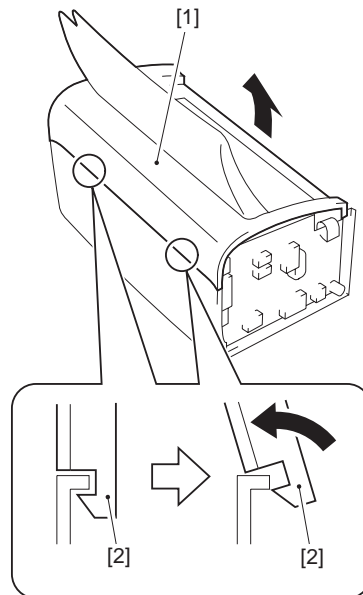

F-3-7



When mounting the upper cover, be sure to fit the 2 hooks [2] used to release the fixing assembly in the 2 hook holes [1] found in the cover.

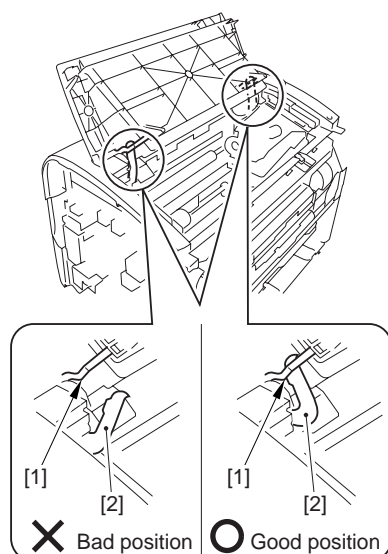

F-3-8

3.1.1.5 Removing the Rear Cover

0008-0972

1) Slide the rear cover [1] in the direction of the arrow to detach.

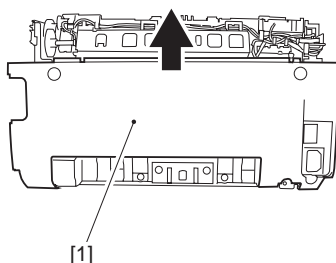

F-3-9

3.1.2 Right Cover

3.1.2.1 Removing the Right Cover

0008-0965

- 1) Open the delivery tray [1].
- 2) Open the upper cover [2].
- 3) Remove the screw [3].

4) Remove the 4 claws [4], and slide the right cover [5] in the direction of the arrow.

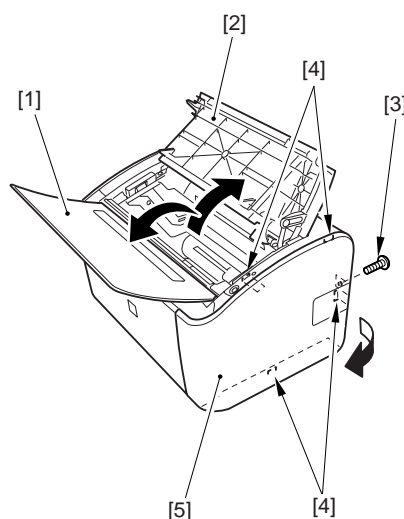

F-3-10

5) Remove the 3 claws [1], and slide the right cover [2] in the direction of the arrow to detach.

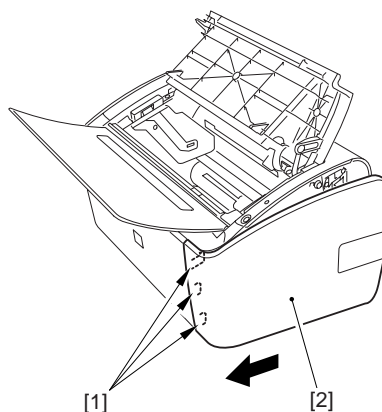

F-3-11

3.1.3 Left Cover

3.1.3.1 Removing the Left Cover

0008-0966

- 1) Open the delivery tray [1].
- 2) Open the upper cover [2].
- 3) Remove the screw [3].

4) Remove the 4 claws [4], and slide the left cover [5] in the direction of the arrow.

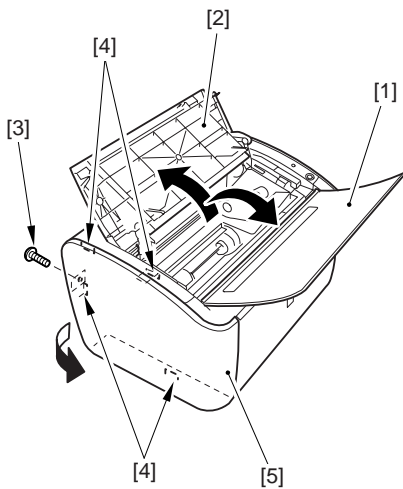

F-3-12

[5] in the direction of the arrow.

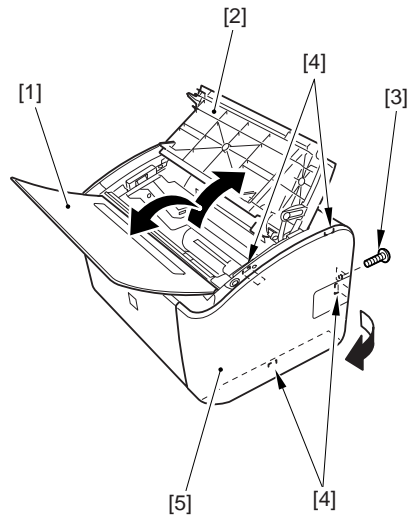

F-3-14

5) Remove the 3 claws [1], and slide the left cover [2] in the direction of the arrow to detach.

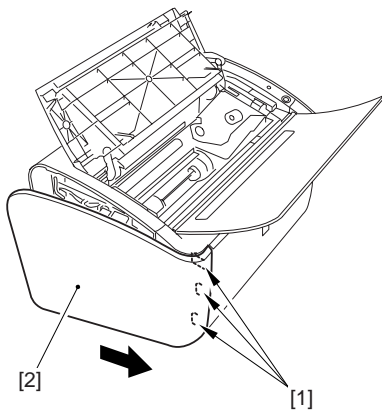

F-3-13

5) Remove the 3 claws [1], and slide the right cover [2] in the direction of the arrow to detach.

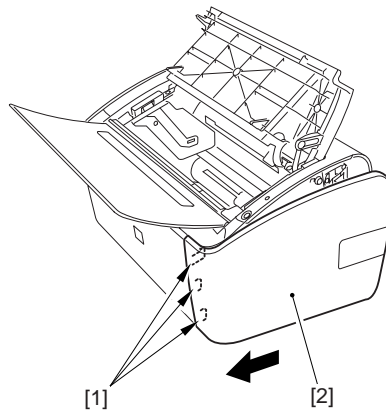

F-3-15

3.1.4 Upper Cover

3.1.4.1 Removing the Right Cover

0008-3533

- 1) Open the delivery tray [1].
- 2) Open the upper cover [2].
- 3) Remove the screw [3].
- 4) Remove the 4 claws [4], and slide the right cover

3.1.4.2 Removing the Left Cover

0008-3534

- 1) Open the delivery tray [1].
- 2) Open the upper cover [2].
- 3) Remove the screw [3].
- 4) Remove the 4 claws [4], and slide the left cover [5] in the direction of the arrow.

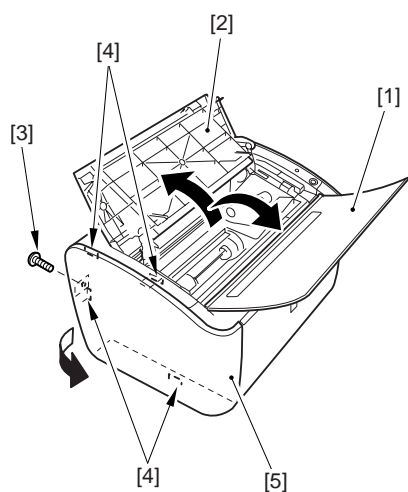

F-3-16

5) Remove the 3 claws [1], and slide the left cover [2] in the direction of the arrow to detach.

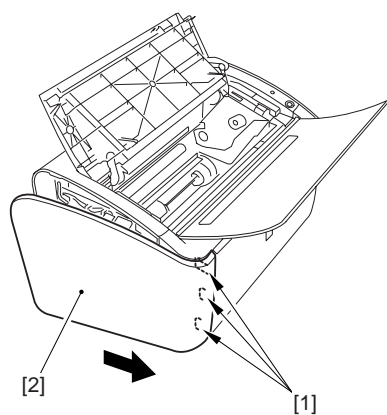

F-3-17

3.1.4.3 Removing the Front Cover

0008-3535

- 1) Remove the 2 claws [1].
- 2) Slide the front cover [2] in the direction of the arrow to detach.

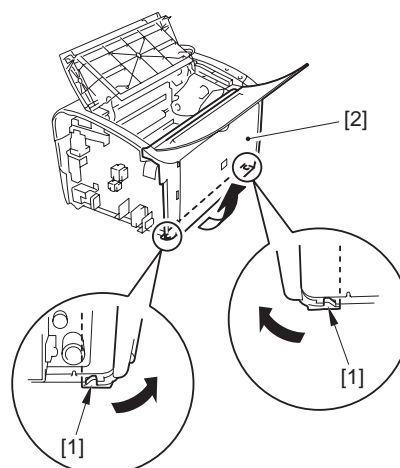

F-3-18

3.1.4.4 Removing the Upper Cover

0008-0971

- 1) Free the link stop [2] from the door link [1].
- 2) Remove the 2 screws [3].

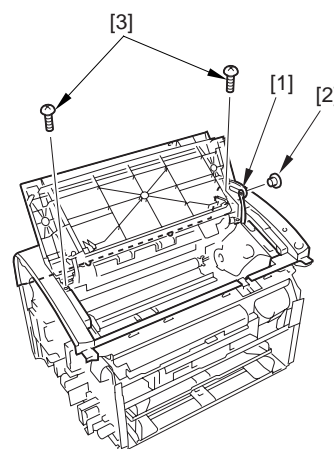

F-3-19

- 3) Slide the upper cover [1] in the direction of the arrow.
- 4) Remove the 2 claws [2] of the upper cover, and detach the cover.

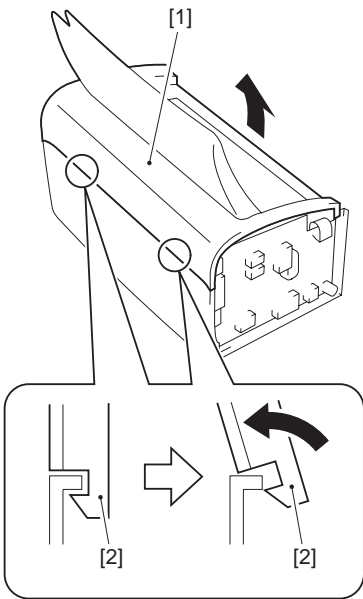

F-3-20



When mounting the upper cover, be sure to fit the 2 hooks [2] used to release the fixing assembly in the 2 hook holes [1] found in the cover.

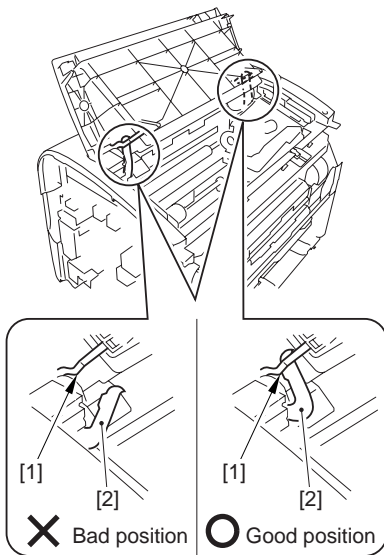

F-3-21

3.1.5 Front Cover

3.1.5.1 Removing the Right Cover

0008-3531

- 1) Open the delivery tray [1].
- 2) Open the upper cover [2].
- 3) Remove the screw [3].
- 4) Remove the 4 claws [4], and slide the right cover [5] in the direction of the arrow.

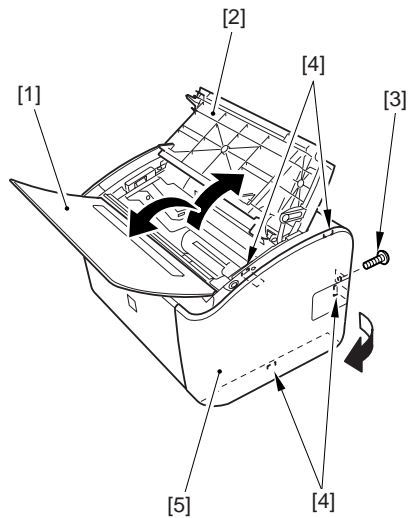

F-3-22

- 5) Remove the 3 claws [1], and slide the right cover [2] in the direction of the arrow to detach.

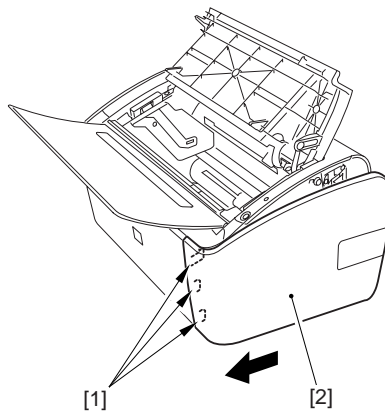

F-3-23

3.1.5.2 Removing the Left Cover

0008-3532

- 1) Open the delivery tray [1].
- 2) Open the upper cover [2].
- 3) Remove the screw [3].
- 4) Remove the 4 claws [4], and slide the left cover [5] in the direction of the arrow.

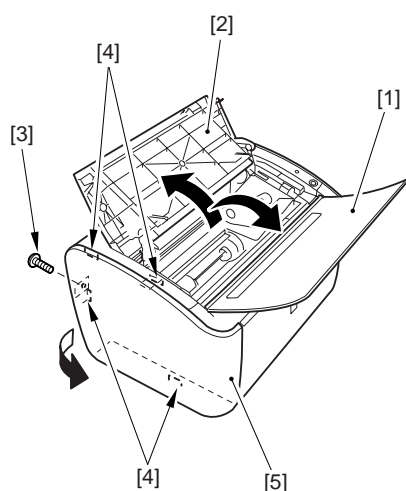

F-3-24

- 5) Remove the 3 claws [1], and slide the left cover [2] in the direction of the arrow to detach.

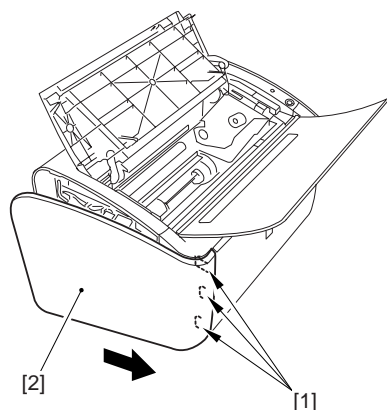

F-3-25

3.1.5.3 Removing the Front Cover

0008-0967

- 1) Remove the 2 claws [1].
- 2) Slide the front cover [2] in the direction of the arrow to detach.

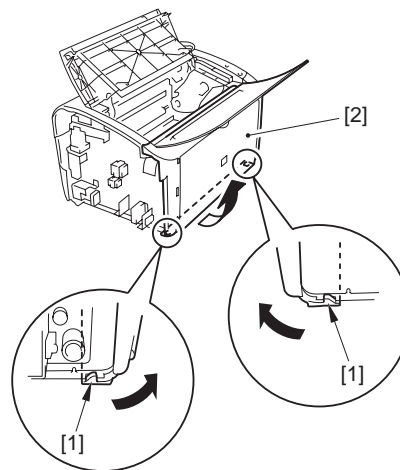

F-3-26

3.1.6 Delivery Tray

3.1.6.1 Removing the Delivery Tray

0008-0970

- 1) Remove the 2 shafts [1] of the delivery tray [2], and detach the tray.

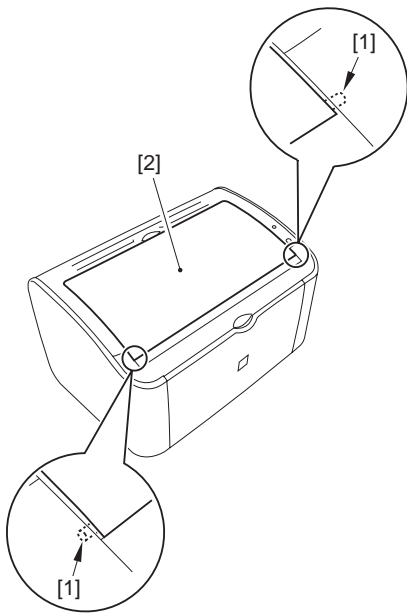

F-3-27

3.1.7 Pickup Tray

3.1.7.1 Removing the Pickup Tray

0008-0969

1) Free the 2 shafts [1] of the pickup tray [2], and detach the tray.

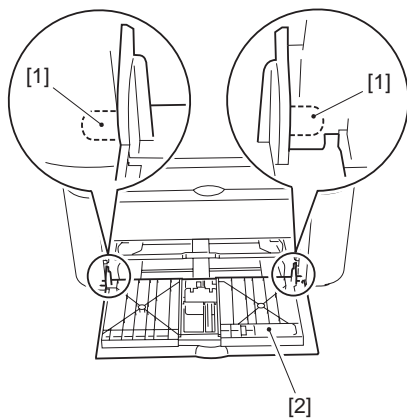

F-3-28

3.1.8 Engine controller board

3.1.8.1 Removing the Right Cover

0008-3542

- 1) Open the delivery tray [1].
- 2) Open the upper cover [2].
- 3) Remove the screw [3].
- 4) Remove the 4 claws [4], and slide the right cover [5] in the direction of the arrow.

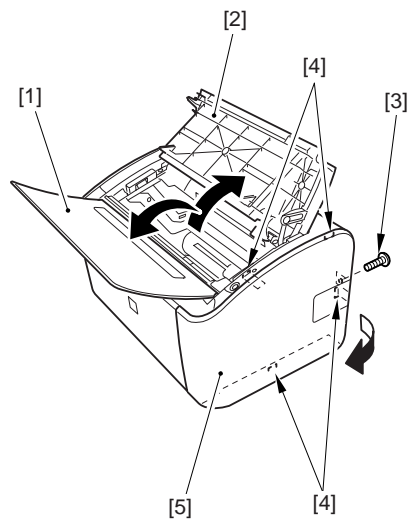

F-3-29

5) Remove the 3 claws [1], and slide the right cover [2] in the direction of the arrow to detach.

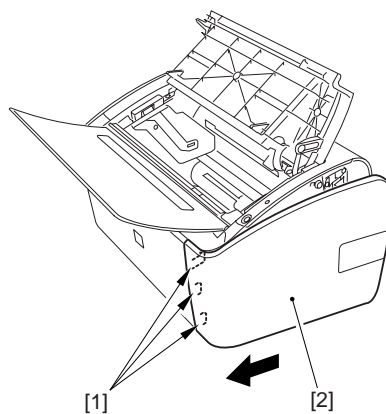

F-3-30

3.1.8.2 Removing the Left Cover

0008-3543

- 1) Open the delivery tray [1].
- 2) Open the upper cover [2].
- 3) Remove the screw [3].
- 4) Remove the 4 claws [4], and slide the left cover [5] in the direction of the arrow.

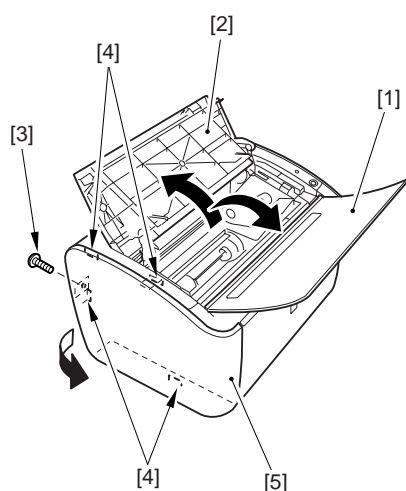

F-3-31

- 5) Remove the 3 claws [1], and slide the left cover [2] in the direction of the arrow to detach.

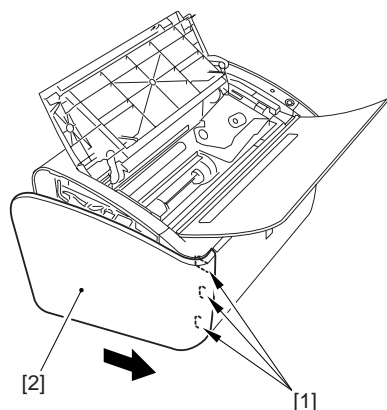

F-3-32

3.1.8.3 Removing the Front Cover

0008-3544

- 1) Remove the 2 claws [1].
- 2) Slide the front cover [2] in the direction of the arrow to detach.

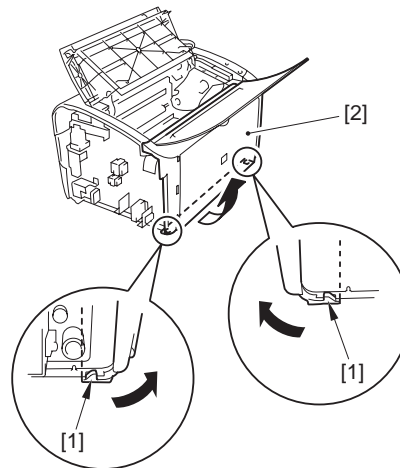

F-3-33

3.1.8.4 Removing the Engine Controller PCB

0008-1113

- 1) Remove the 4 screws [1].

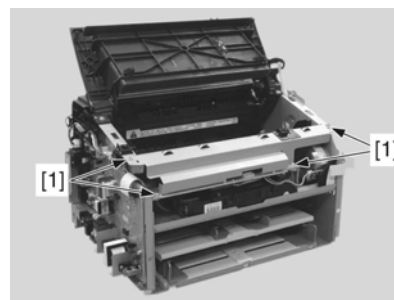

F-3-34

- 2) Remove the 2 claws [1], and detach the scanner cover [2].

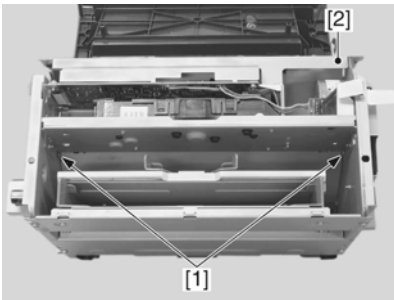

F-3-35

- 3) Free the 2 flat cables [1].
- 4) While pushing on the pin [2], free the cable guide [3].
- 5) Disconnect the connector [4].
- 6) Remove the screw [5].

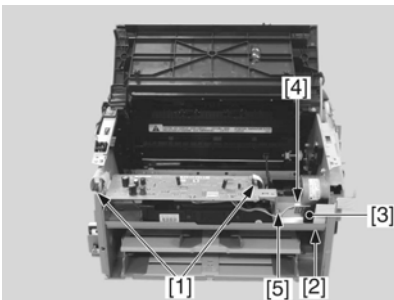

F-3-36

- 7) Disconnect the cable connector [1] found on the right side of the machine; then, detach the full flat cable [2].

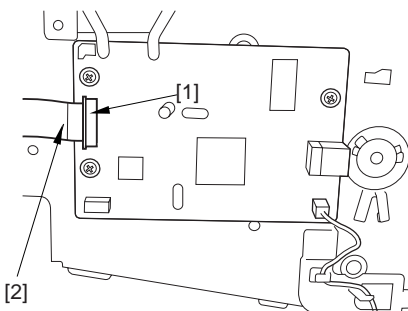

F-3-37

- 8) Disconnect the connector [1], and detach the engine

controller PCB [2].

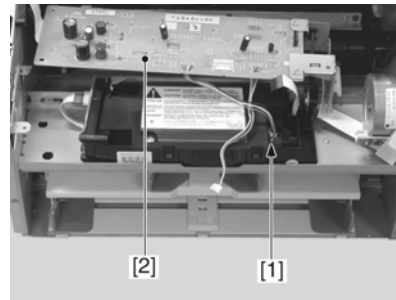

F-3-38

3.1.9 Video Controller Board

3.1.9.1 Removing the Right Cover

0008-7939

- 1) Open the delivery tray [1].
- 2) Open the upper cover [2].
- 3) Remove the screw [3].
- 4) Remove the 4 claws [4], and slide the right cover [5] in the direction of the arrow.

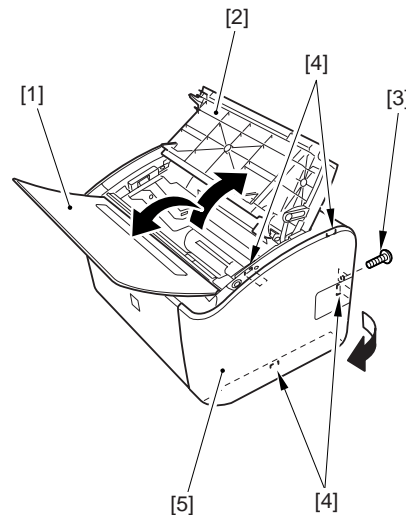

F-3-39

- 5) Remove the 3 claws [1], and slide the right cover [2] in the direction of the arrow to detach.

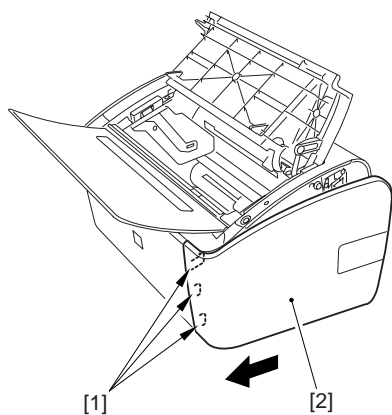

F-3-40

3.1.9.2 Removing the Video Controller PCB

0008-1120

- 1) Disconnect the cable connector [1]; then, detach the flat cable [2].
- 2) Remove the 3 screws [3], and disconnect the connector [4]; then, detach the video controller PCB [5].

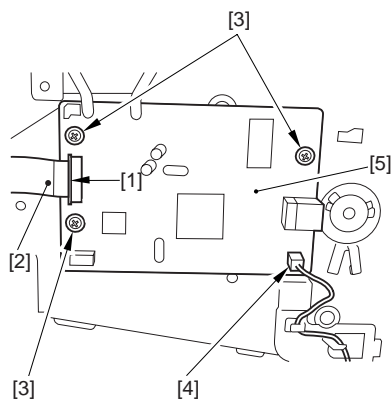

F-3-41

3.1.10 Power supply board

3.1.10.1 Removing the Right Cover

0008-3571

- 1) Open the delivery tray [1].
- 2) Open the upper cover [2].
- 3) Remove the screw [3].
- 4) Remove the 4 claws [4], and slide the right cover [5] in the direction of the arrow.

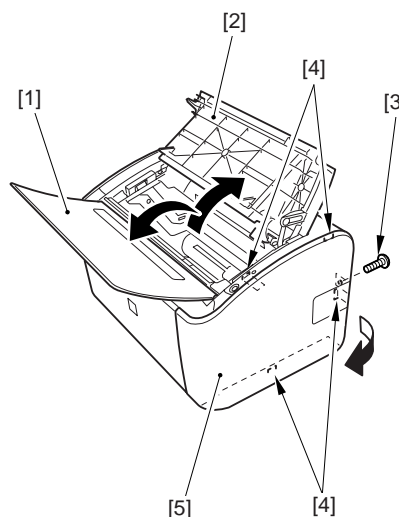

F-3-42

- 5) Remove the 3 claws [1], and slide the right cover [2] in the direction of the arrow to detach.

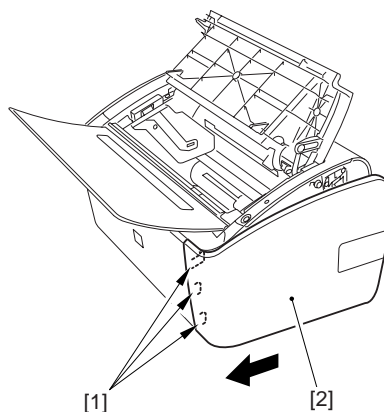

F-3-43

3.1.10.2 Removing the Left Cover

0008-3572

- 1) Open the delivery tray [1].
- 2) Open the upper cover [2].
- 3) Remove the screw [3].

4) Remove the 4 claws [4], and slide the left cover [5] in the direction of the arrow.

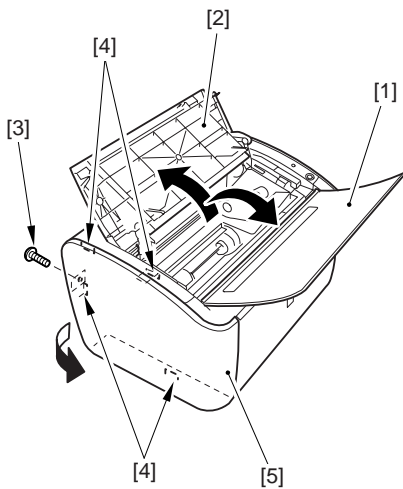

F-3-44

5) Remove the 3 claws [1], and slide the left cover [2] in the direction of the arrow to detach.

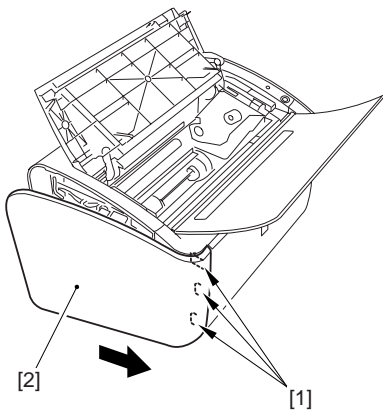

F-3-45

3.1.10.3 Removing the Front Cover

0008-3573

- 1) Remove the 2 claws [1].
- 2) Slide the front cover [2] in the direction of the arrow to detach.

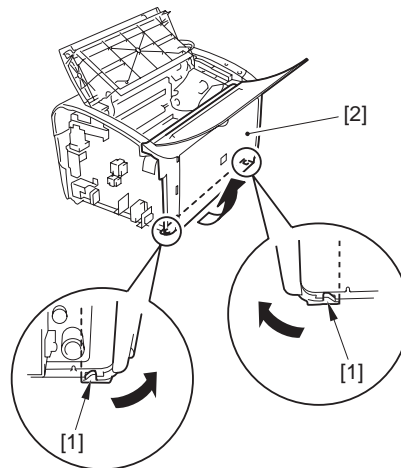

F-3-46

3.1.10.4 Removing the Upper Cover

0008-3574

- 1) Free the link stop [2] from the door link [1].
- 2) Remove the 2 screws [3].

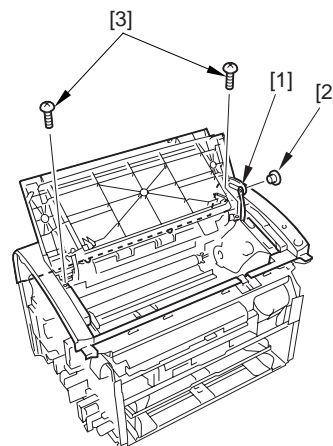

F-3-47

3) Slide the upper cover [1] in the direction of the arrow.

4) Remove the 2 claws [2] of the upper cover, and detach the cover.

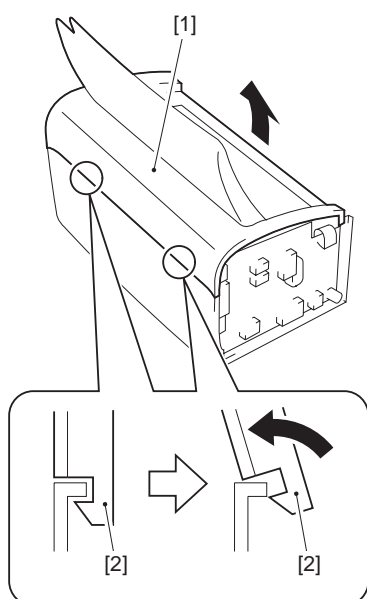

F-3-48



When mounting the upper cover, be sure to fit the 2 hooks [2] used to release the fixing assembly in the 2 hook holes [1] found in the cover.

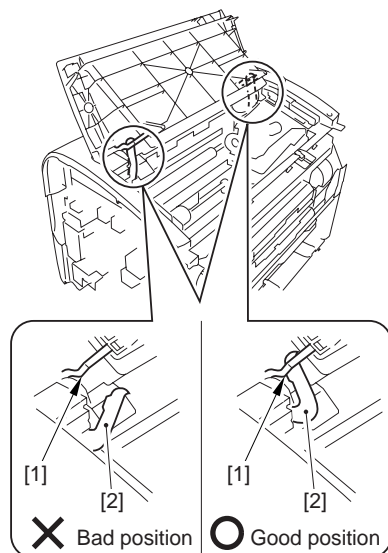

F-3-49

3.1.10.5 Removing the Rear Cover

0008-3575

1) Slide the rear cover [1] in the direction of the arrow to detach.

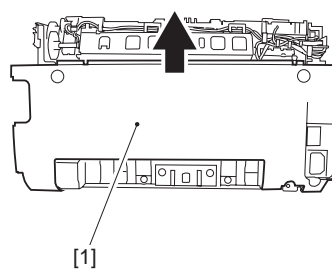

F-3-50

3.1.10.6 Removing the Power Supply PCB

0008-1107

1) Disconnect the flat cable [1].
2) Disconnect the 4 connectors [2], and free the harness [4] from the harness guide [3].

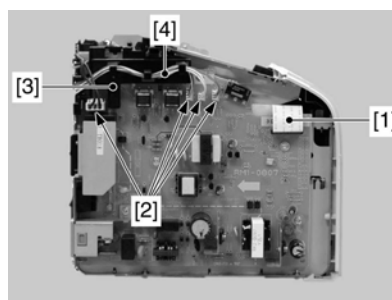

F-3-51

3) Disconnect the high-voltage connector [1].
4) Remove the 6 screws [2], and detach the power supply PCB [3].

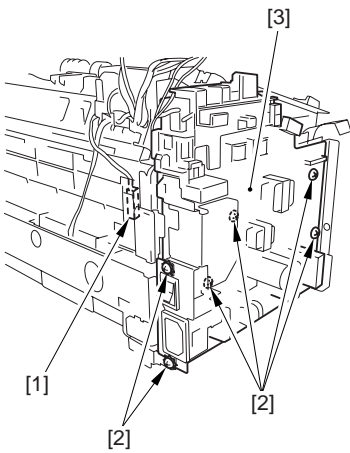

F-3-52

[2] in the direction of the arrow to detach.

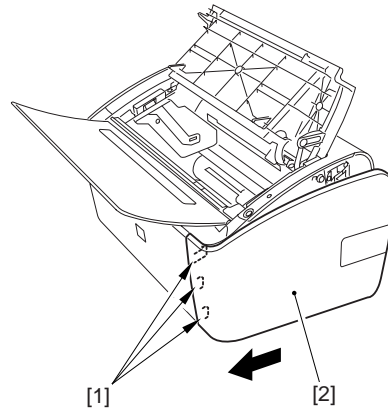

F-3-54

3.1.11 Top sensor

3.1.11.1 Removing the Right Cover

0008-3576

- 1) Open the delivery tray [1].
- 2) Open the upper cover [2].
- 3) Remove the screw [3].
- 4) Remove the 4 claws [4], and slide the right cover [5] in the direction of the arrow.

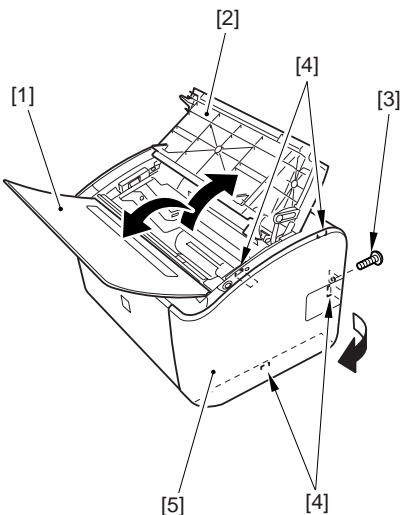

F-3-53

3.1.11.2 Removing the Left Cover

0008-3577

- 1) Open the delivery tray [1].
- 2) Open the upper cover [2].
- 3) Remove the screw [3].
- 4) Remove the 4 claws [4], and slide the left cover [5] in the direction of the arrow.

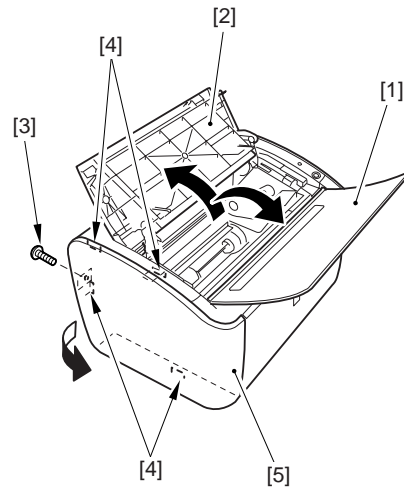

F-3-55

- 5) Remove the 3 claws [1], and slide the left cover [2] in the direction of the arrow to detach.

- 5) Remove the 3 claws [1], and slide the right cover

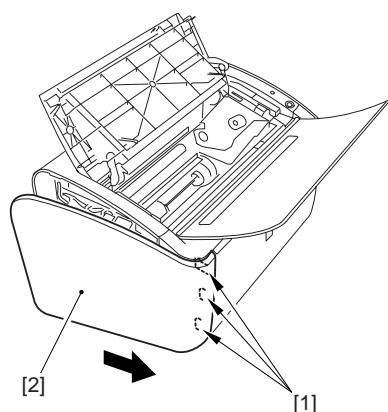

F-3-56

3.1.11.3 Removing the Front Cover

0008-3578

- 1) Remove the 2 claws [1].
- 2) Slide the front cover [2] in the direction of the arrow to detach.

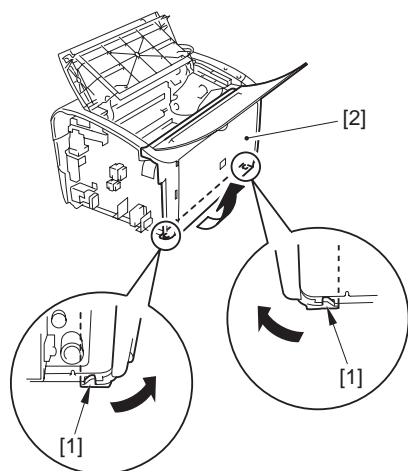

F-3-57

3.1.11.4 Removing the Upper Cover

0008-3579

- 1) Free the link stop [2] from the door link [1].
- 2) Remove the 2 screws [3].

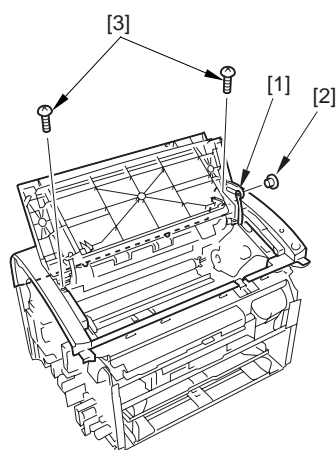

F-3-58

- 3) Slide the upper cover [1] in the direction of the arrow.
- 4) Remove the 2 claws [2] of the upper cover, and detach the cover.

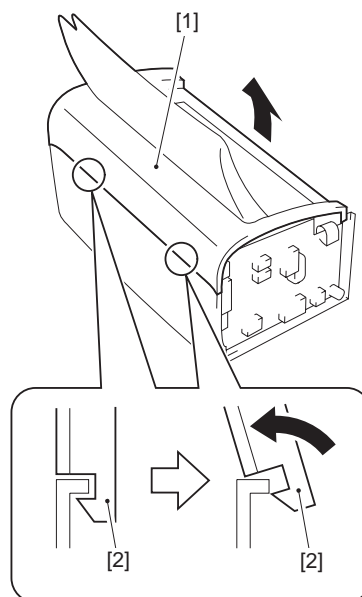

F-3-59



When mounting the upper cover, be sure to fit the 2 hooks [2] used to release the fixing assembly in the 2 hook holes [1] found in the cover.

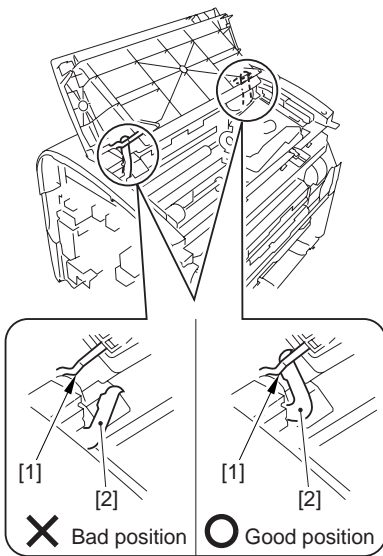

F-3-60

3.1.11.5 Removing the Rear Cover

0008-3580

1) Slide the rear cover [1] in the direction of the arrow to detach.

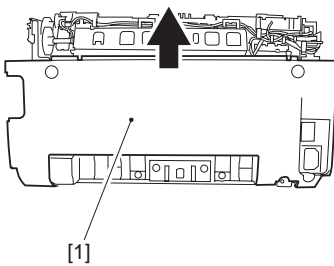

F-3-61

3.1.11.6 Removing the Paper Leading Edge/Paper Width Sensor PCB

0008-1122

1) Disconnect the connector [1], and free the harness [3] from the harness guide [2].

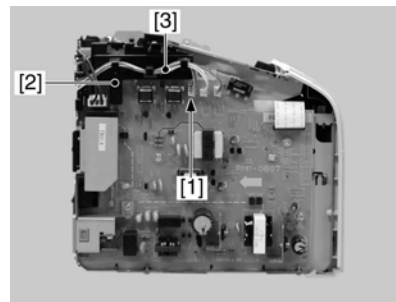

F-3-62

2) Remove the 2 screws [1], and detach the rear plate [2].

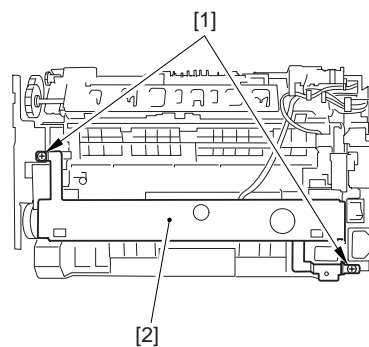

F-3-63

3) Remove the 2 claws [1], and detach the paper leading edge/paper width sensor PCB [2].

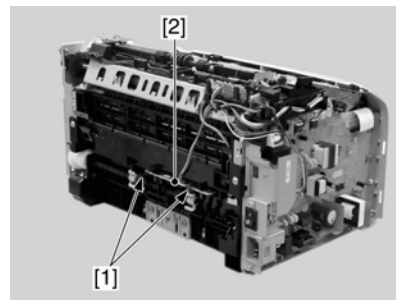

F-3-64

3.2 LASER EXPOSURE SYSTEM

3.2.1 Laser Scanner Unit

3.2.1.1 Removing the Right Cover

0008-3548

- 1) Open the delivery tray [1].
- 2) Open the upper cover [2].
- 3) Remove the screw [3].
- 4) Remove the 4 claws [4], and slide the right cover [5] in the direction of the arrow.

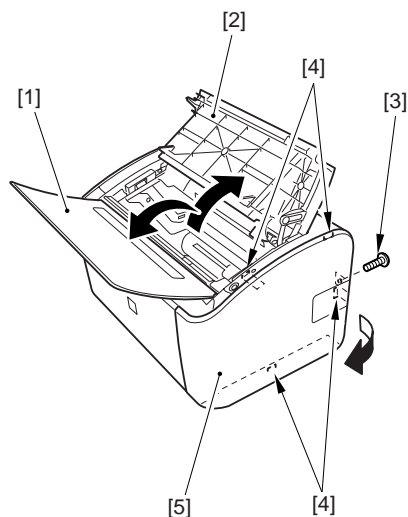

F-3-65

- 5) Remove the 3 claws [1], and slide the right cover [2] in the direction of the arrow to detach.

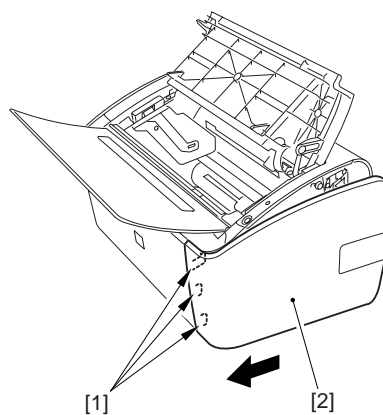

F-3-66

3.2.1.2 Removing the Left Cover

0008-3549

- 1) Open the delivery tray [1].
- 2) Open the upper cover [2].
- 3) Remove the screw [3].
- 4) Remove the 4 claws [4], and slide the left cover [5] in the direction of the arrow.

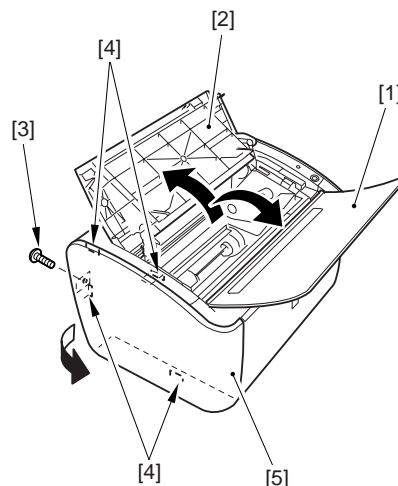

F-3-67

- 5) Remove the 3 claws [1], and slide the left cover [2] in the direction of the arrow to detach.

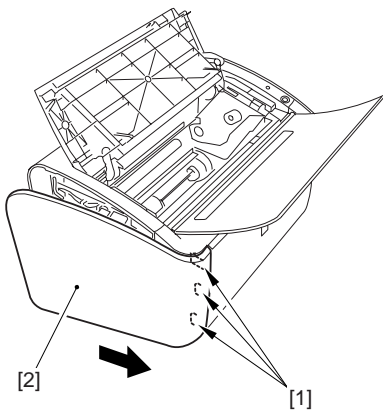

F-3-68

3.2.1.3 Removing the Front Cover

0008-3550

- 1) Remove the 2 claws [1].
- 2) Slide the front cover [2] in the direction of the arrow to detach.

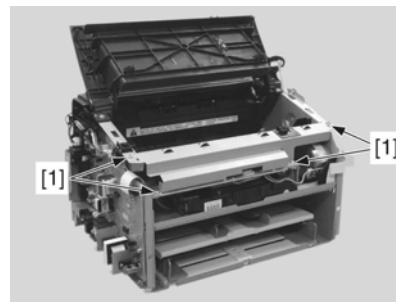

F-3-70

- 2) Remove the 2 claws [1], and detach the scanner cover [2].

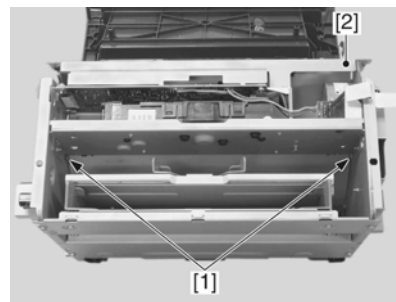

F-3-71

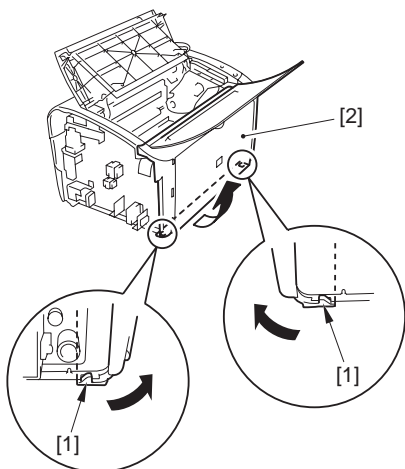

F-3-69

- 3) Free the 2 flat cables [1].
- 4) While pushing on the pin [2], free the cable guide [3].
- 5) Disconnect the connector [4].
- 6) Remove the screw [5].

3.2.1.4 Removing the Engine Controller PCB

0008-3551

- 1) Remove the 4 screws [1].

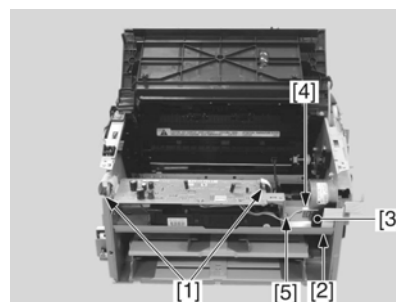

F-3-72

- 7) Disconnect the cable connector [1] found on the right side of the machine; then, detach the full flat cable [2].

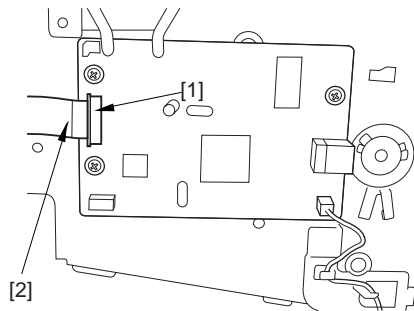

F-3-73

8) Disconnect the connector [1], and detach the engine controller PCB [2].

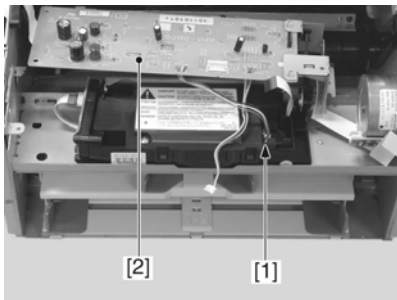

F-3-74

3.2.1.5 Removing the Laser Scanner Unit

0008-1063

1) Remove the 4 screws [1], and detach the laser scanner unit [2].

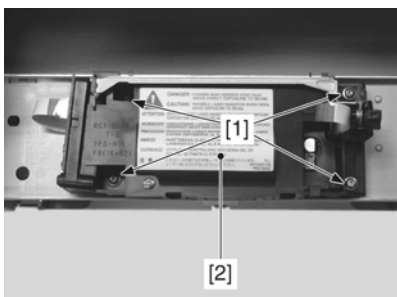

F-3-75

3.3 IMAGE FORMATION SYSTEM

3.3.1 Transfer Charging Roller

3.3.1.1 Removing the Transfer

Charging Roller

0008-1071

- 1) Open the delivery tray.
- 2) Open the upper cover.
- 3) Remove the 2 claws [1] of the transfer charging roller.
- 4) Remove the 2 claws [2] of the transfer guide.
- 5) Detach the transfer charging roller [4] together with the transfer guide [3].
- 6) Detach the transfer charging roller [4] from the transfer guide [3].

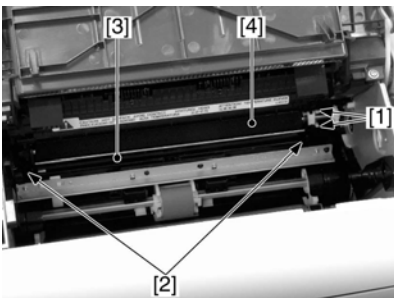

F-3-76



When removing the transfer roller from the machine, free its right side ([1] in the figure), and pull it out toward the right.

3.4 PICKUP AND FEEDING SYSTEM

3.4.1 Pickup Unit

3.4.1.1 Removing the Transfer Charging Roller

0008-3559

- 1) Open the delivery tray.
- 2) Open the upper cover.
- 3) Remove the 2 claws [1] of the transfer charging roller.
- 4) Remove the 2 claws [2] of the transfer guide.
- 5) Detach the transfer charging roller [4] together with the transfer guide [3].
- 6) Detach the transfer charging roller [4] from the transfer guide [3].

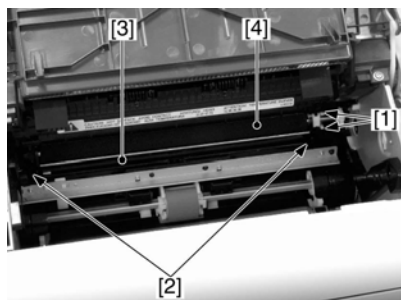

F-3-77



When removing the transfer roller from the machine, free its right side ([1] in the figure), and pull it out toward the right.

3.4.1.2 Removing the Right Cover

0008-3586

- 1) Open the delivery tray [1].
- 2) Open the upper cover [2].
- 3) Remove the screw [3].
- 4) Remove the 4 claws [4], and slide the right cover [5] in the direction of the arrow.

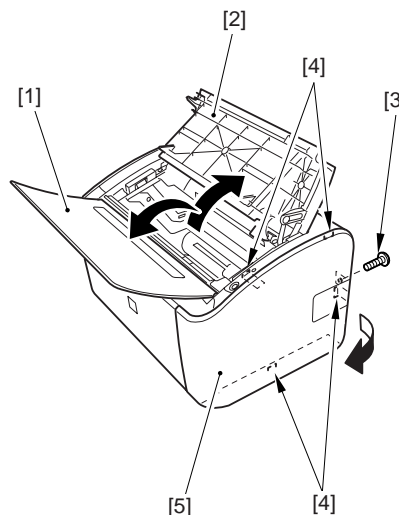

F-3-78

- 5) Remove the 3 claws [1], and slide the right cover [2] in the direction of the arrow to detach.

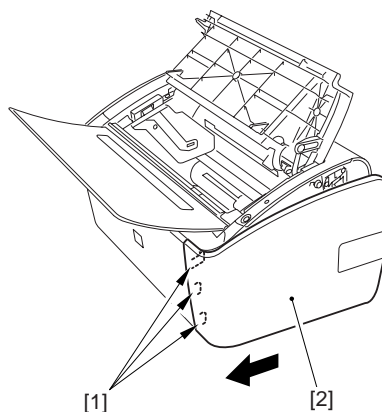

F-3-79

3.4.1.3 Removing the Left Cover

0008-3587

- 1) Open the delivery tray [1].
- 2) Open the upper cover [2].
- 3) Remove the screw [3].

4) Remove the 4 claws [4], and slide the left cover [5] in the direction of the arrow.

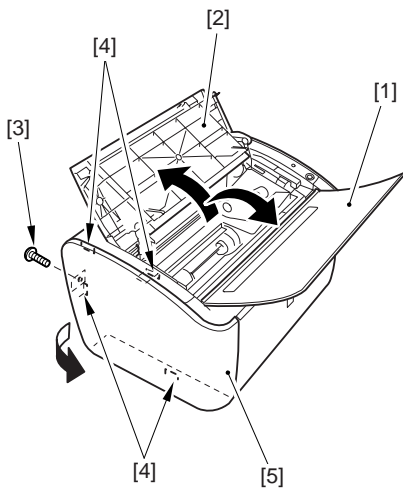

F-3-80

5) Remove the 3 claws [1], and slide the left cover [2] in the direction of the arrow to detach.

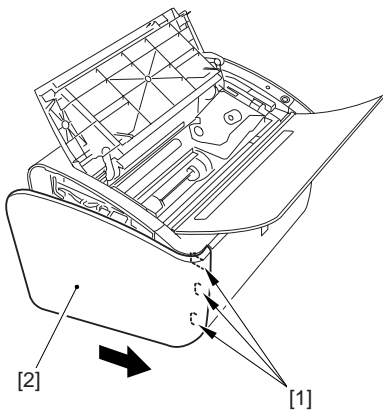

F-3-81

3.4.1.4 Removing the Front Cover

0008-3588

- 1) Remove the 2 claws [1].
- 2) Slide the front cover [2] in the direction of the arrow to detach.

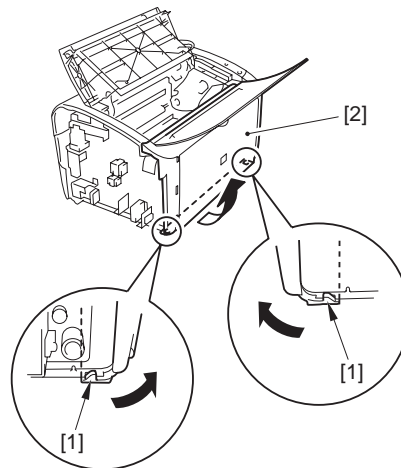

F-3-82

3.4.1.5 Removing the Upper Cover

0008-3589

- 1) Free the link stop [2] from the door link [1].
- 2) Remove the 2 screws [3].

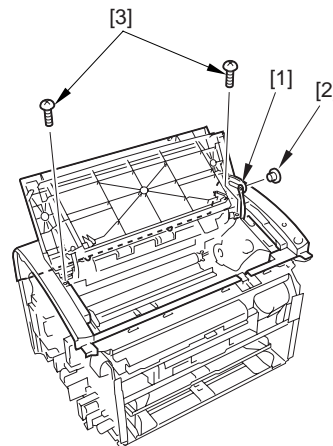

F-3-83

- 3) Slide the upper cover [1] in the direction of the arrow.
- 4) Remove the 2 claws [2] of the upper cover, and detach the cover.

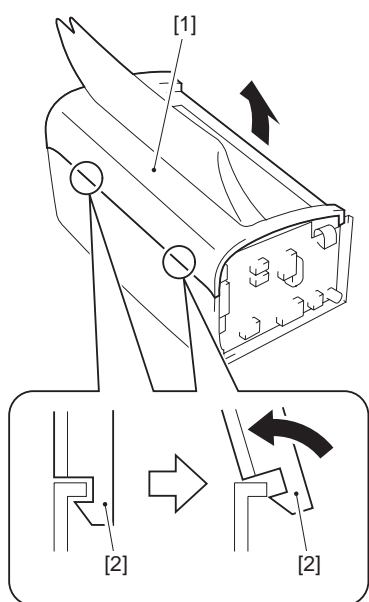

F-3-84



When mounting the upper cover, be sure to fit the 2 hooks [2] used to release the fixing assembly in the 2 hook holes [1] found in the cover.

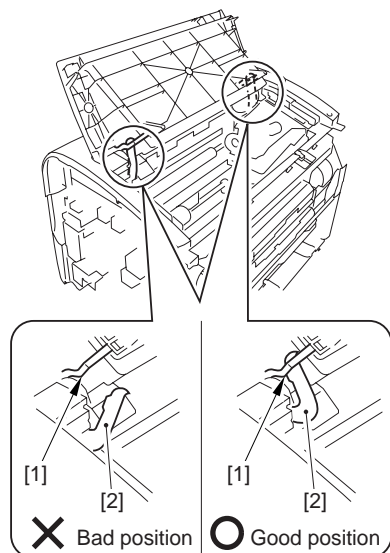

F-3-85

3.4.1.6 Removing the Rear Cover

0008-3590

1) Slide the rear cover [1] in the direction of the arrow to detach.

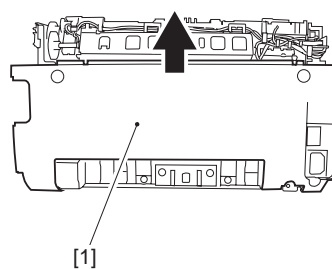

F-3-86

3.4.1.7 Removing the Power Supply PCB

0009-2767

1) Disconnect the flat cable [1].
 2) Disconnect the 4 connectors [2], and free the harness [4] from the harness guide [3].

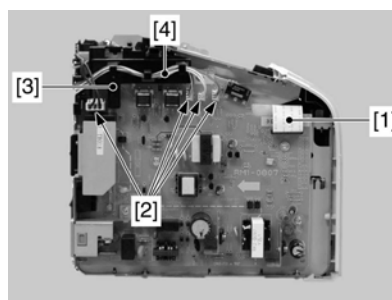

F-3-87

3) Disconnect the high-voltage connector [1].
 4) Remove the 6 screws [2], and detach the power supply PCB [3].

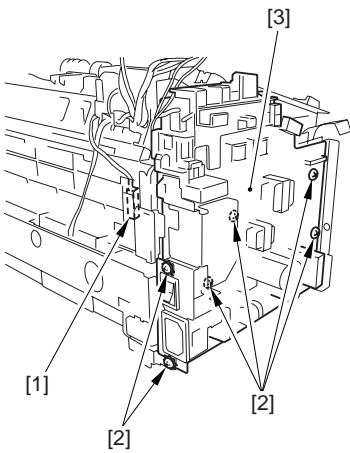

F-3-88

3.4.1.8 Removing the Fixing Assembly

0008-3591

1) Remove the 3 screws [1], and detach the fixing assembly [2].

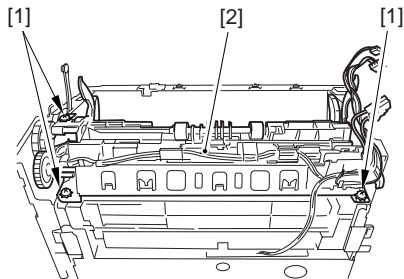

F-3-89

3.4.1.9 Removing the Pickup Assembly

0008-1059

1) Remove the 2 screws [1], and detach the rear plate [2].

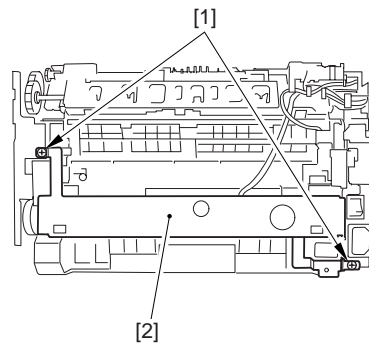

F-3-90

2) Detach the 6 adhesive segments [1] of the plastic film sheet.

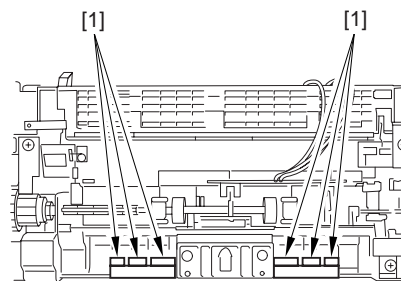

F-3-91

3) Remove the 6 screws [1], and detach the pickup assembly [2].

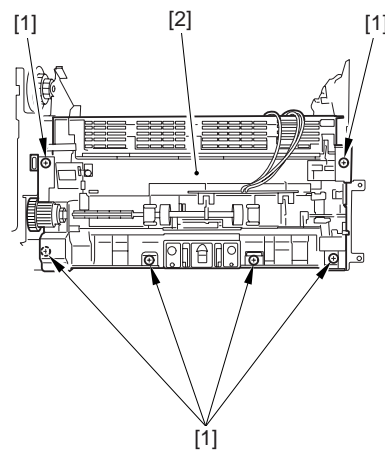

F-3-92

3.4.2 Manual Pickup Roller

3.4.2.1 Removing the Pickup Roller

0008-1076

- 1) Open the delivery tray.
- 2) Open the upper cover.
- 3) While picking the 2 claws [1], detach the pickup roller [2].

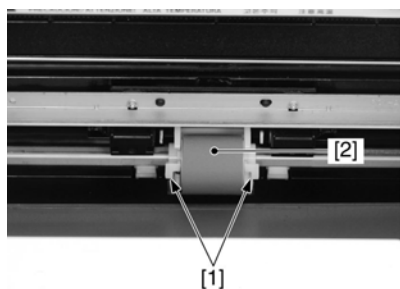

F-3-93

3.4.3 Multi-purpose Pickup Solenoid

3.4.3.1 Removing the Right Cover

0008-3546

- 1) Open the delivery tray [1].
- 2) Open the upper cover [2].
- 3) Remove the screw [3].
- 4) Remove the 4 claws [4], and slide the right cover [5] in the direction of the arrow.

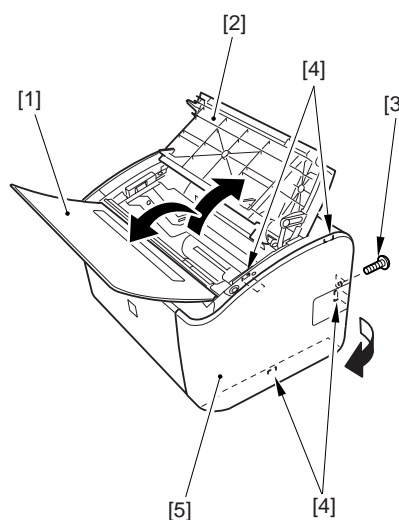

F-3-94

- 5) Remove the 3 claws [1], and slide the right cover [2] in the direction of the arrow to detach.

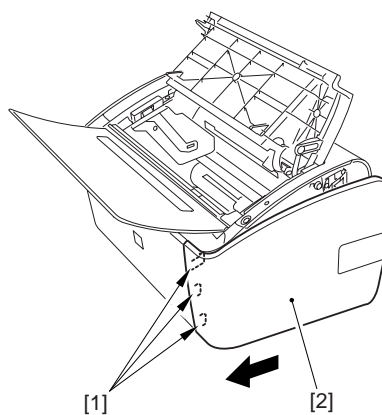

F-3-95

3.4.3.2 Removing the Pickup Solenoid

0008-1890

- 1) Disconnect the connector [1], and remove the screw [2]; then, detach the pickup solenoid [3].

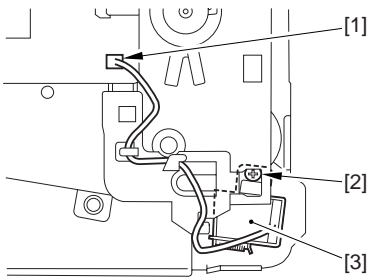

F-3-96

3.4.4 Manual Separation Pad

3.4.4.1 Removing the Separation Pad

0008-1070

1) Remove the 2 screws [1], and detach the separation pad [2].

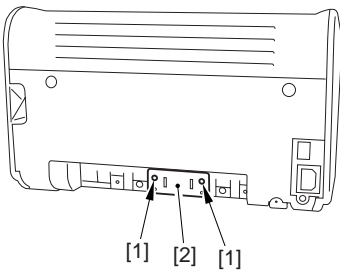

F-3-97

3.4.5 Main Motor

3.4.5.1 Removing the Right Cover

0008-3552

- 1) Open the delivery tray [1].
- 2) Open the upper cover [2].
- 3) Remove the screw [3].
- 4) Remove the 4 claws [4], and slide the right cover [5] in the direction of the arrow.

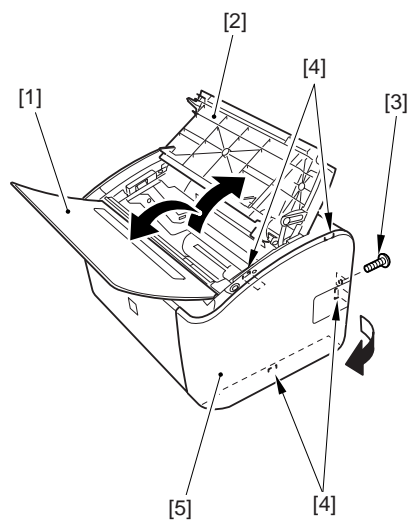

F-3-98

5) Remove the 3 claws [1], and slide the right cover [2] in the direction of the arrow to detach.

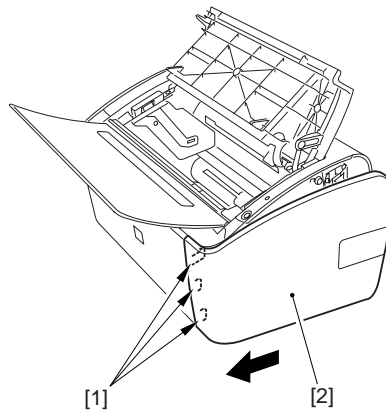

F-3-99

3.4.5.2 Removing the Left Cover

0008-3553

- 1) Open the delivery tray [1].
- 2) Open the upper cover [2].
- 3) Remove the screw [3].
- 4) Remove the 4 claws [4], and slide the left cover [5] in the direction of the arrow.

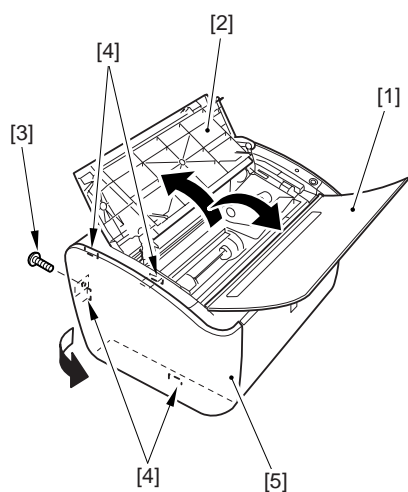

F-3-100

5) Remove the 3 claws [1], and slide the left cover [2] in the direction of the arrow to detach.

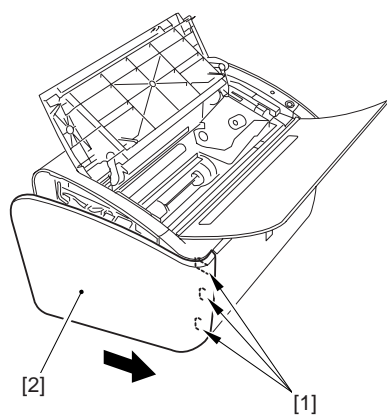

F-3-101

3.4.5.3 Removing the Front Cover

[0008-3555](#)

- 1) Remove the 2 claws [1].
- 2) Slide the front cover [2] in the direction of the arrow to detach.

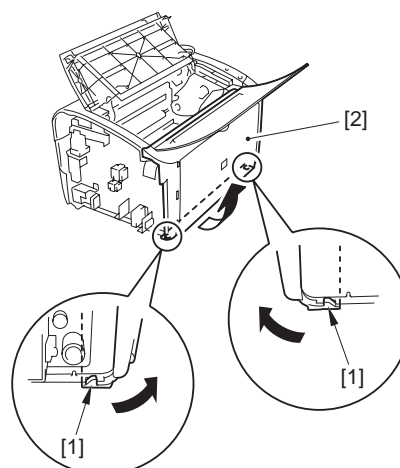

F-3-102

3.4.5.4 Removing the Engine Controller PCB

[0008-3557](#)

- 1) Remove the 4 screws [1].

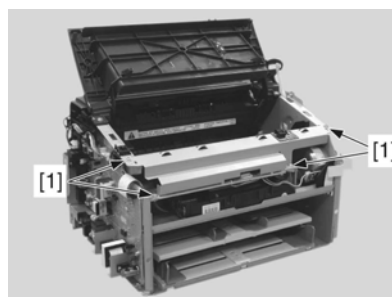

F-3-103

- 2) Remove the 2 claws [1], and detach the scanner cover [2].

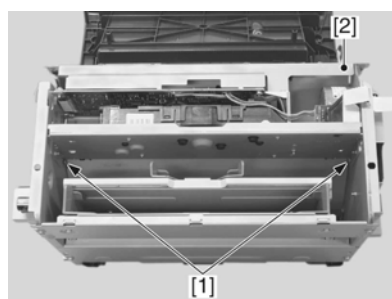

F-3-104

- 3) Free the 2 flat cables [1].
- 4) While pushing on the pin [2], free the cable guide [3].
- 5) Disconnect the connector [4].
- 6) Remove the screw [5].

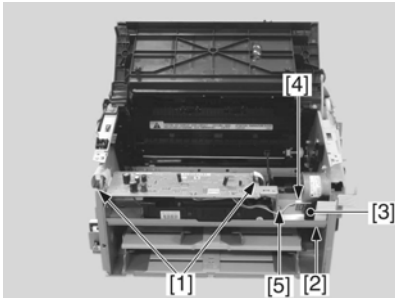

F-3-105

- 7) Disconnect the cable connector [1] found on the right side of the machine; then, detach the full flat cable [2].

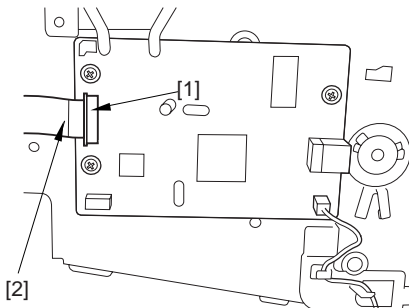

F-3-106

- 8) Disconnect the connector [1], and detach the engine controller PCB [2].

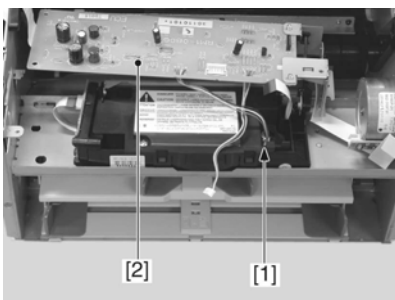

F-3-107

3.4.5.5 Removing the Laser Scanner Unit

0008-3558

- 1) Remove the 4 screws [1], and detach the laser scanner unit [2].

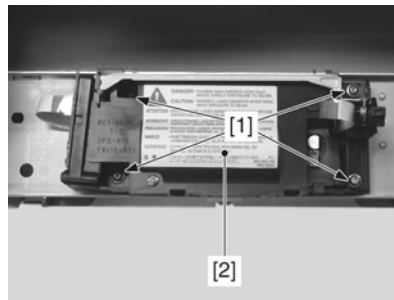

F-3-108

3.4.5.6 Removing the Main Motor

0008-1098

- 1) Remove the 2 screws [1], and detach the main motor [2].

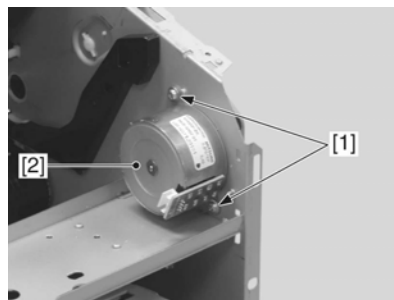

F-3-109

3.5 FIXING SYSTEM

3.5.1 Fixing Unit

3.5.1.1 Removing the Right Cover

0008-3581

- 1) Open the delivery tray [1].
- 2) Open the upper cover [2].
- 3) Remove the screw [3].
- 4) Remove the 4 claws [4], and slide the right cover [5] in the direction of the arrow.

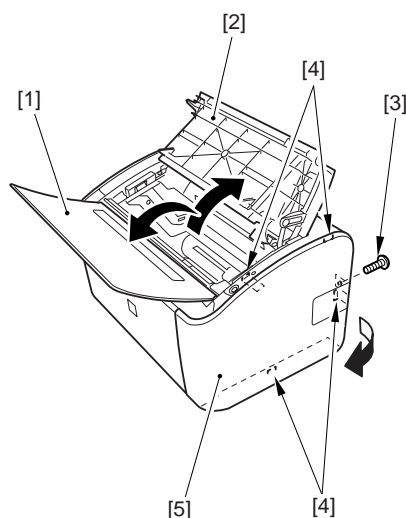

F-3-110

- 5) Remove the 3 claws [1], and slide the right cover [2] in the direction of the arrow to detach.

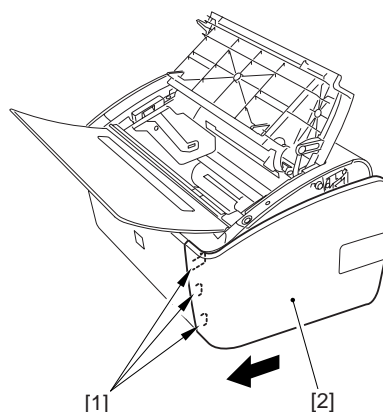

F-3-111

3.5.1.2 Removing the Left Cover

0008-3582

- 1) Open the delivery tray [1].
- 2) Open the upper cover [2].
- 3) Remove the screw [3].
- 4) Remove the 4 claws [4], and slide the left cover [5] in the direction of the arrow.

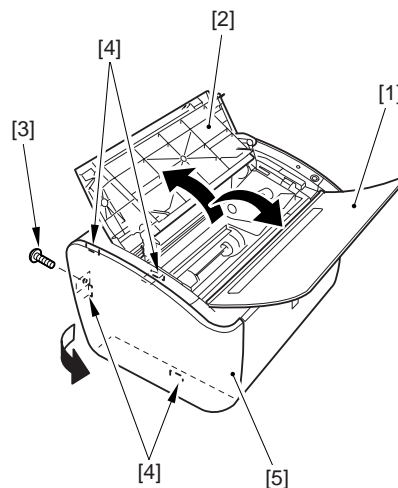

F-3-112

- 5) Remove the 3 claws [1], and slide the left cover [2] in the direction of the arrow to detach.

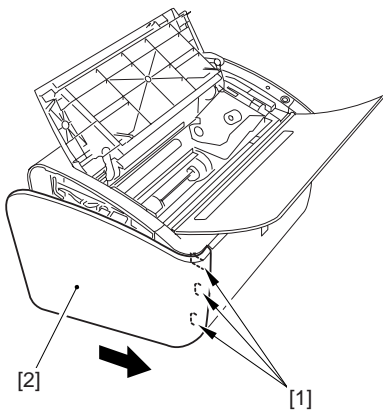

F-3-113

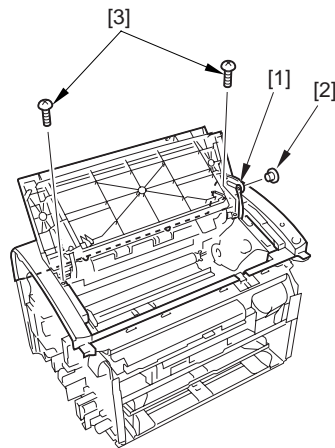

F-3-115

3.5.1.3 Removing the Front Cover

0008-3583

- 1) Remove the 2 claws [1].
- 2) Slide the front cover [2] in the direction of the arrow to detach.

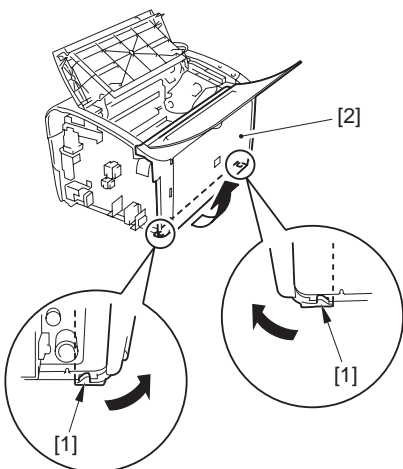

F-3-114

- 3) Slide the upper cover [1] in the direction of the arrow.
- 4) Remove the 2 claws [2] of the upper cover, and detach the cover.

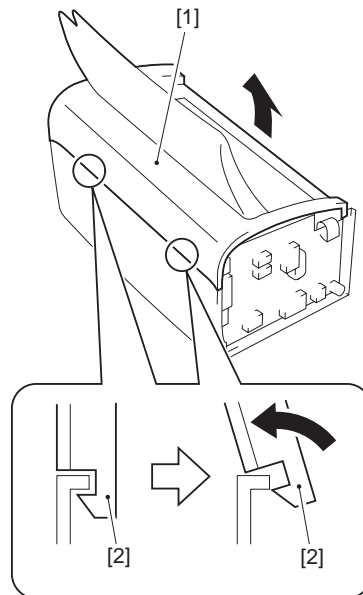

F-3-116

3.5.1.4 Removing the Upper Cover

0008-3584

- 1) Free the link stop [2] from the door link [1].
- 2) Remove the 2 screws [3].



When mounting the upper cover, be sure to fit the 2 hooks [2] used to release the fixing assembly in the 2 hook holes [1] found in the cover.

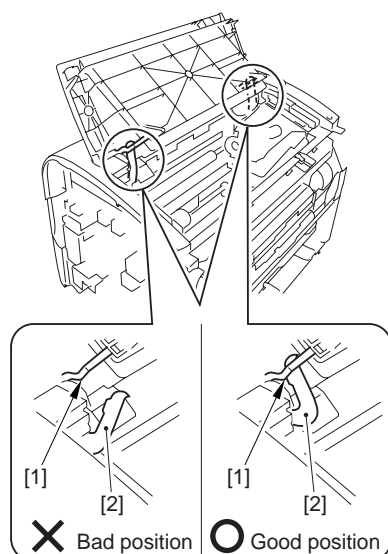

F-3-117

3.5.1.5 Removing the Rear Cover

0008-3585

- 1) Slide the rear cover [1] in the direction of the arrow to detach.

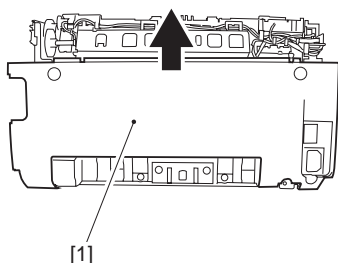

F-3-118

3.5.1.6 Removing the Power Supply PCB

0009-2768

- 1) Disconnect the flat cable [1].
- 2) Disconnect the 4 connectors [2], and free the harness [4] from the harness guide [3].

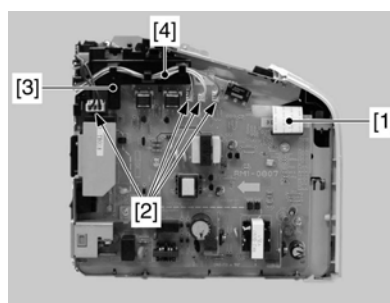

F-3-119

- 3) Disconnect the high-voltage connector [1].
- 4) Remove the 6 screws [2], and detach the power supply PCB [3].

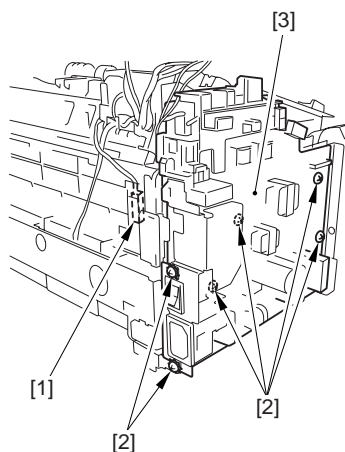

F-3-120

3.5.1.7 Removing the Fixing Assembly

0008-1069

- 1) Remove the 3 screws [1], and detach the fixing assembly [2].

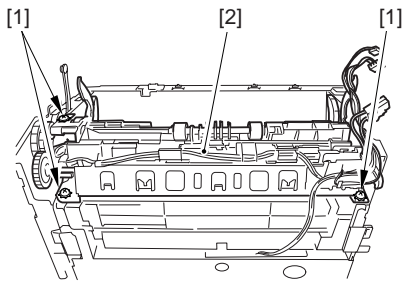

F-3-121

3.5.2 Fixing Film Unit

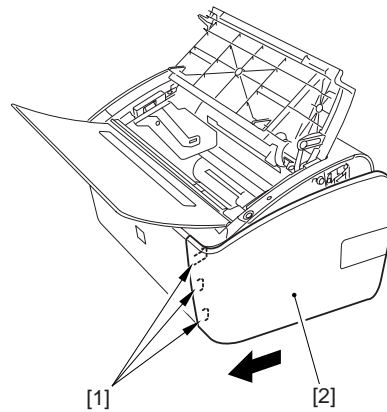

F-3-123

3.5.2.1 Removing the Right Cover

0008-3592

- 1) Open the delivery tray [1].
- 2) Open the upper cover [2].
- 3) Remove the screw [3].
- 4) Remove the 4 claws [4], and slide the right cover [5] in the direction of the arrow.

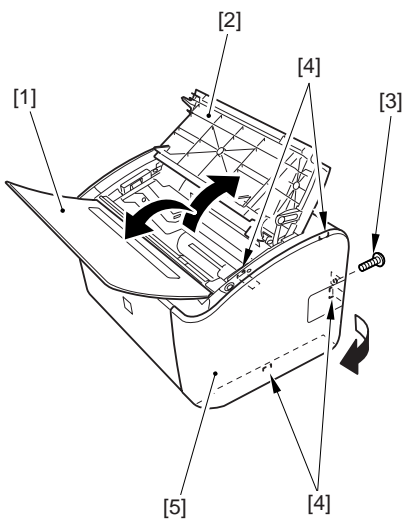

F-3-122

- 5) Remove the 3 claws [1], and slide the right cover [2] in the direction of the arrow to detach.

3.5.2.2 Removing the Left Cover

0008-3596

- 1) Open the delivery tray [1].
- 2) Open the upper cover [2].
- 3) Remove the screw [3].
- 4) Remove the 4 claws [4], and slide the left cover [5] in the direction of the arrow.

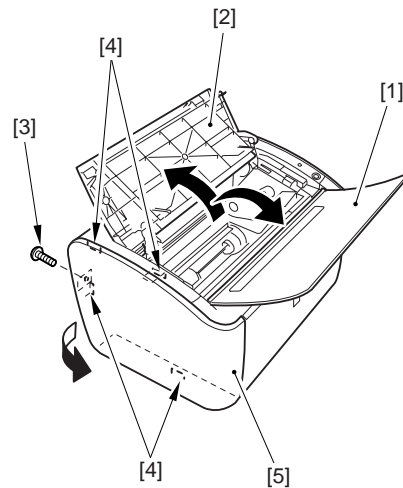

F-3-124

- 5) Remove the 3 claws [1], and slide the left cover [2] in the direction of the arrow to detach.

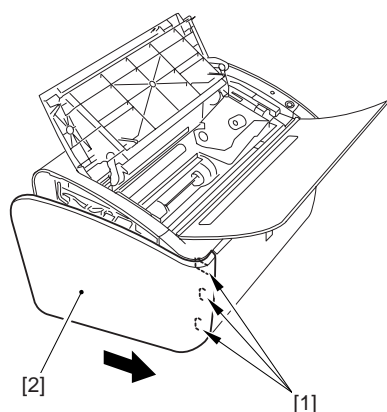

F-3-125

3.5.2.3 Removing the Front Cover

0008-3599

- 1) Remove the 2 claws [1].
- 2) Slide the front cover [2] in the direction of the arrow to detach.

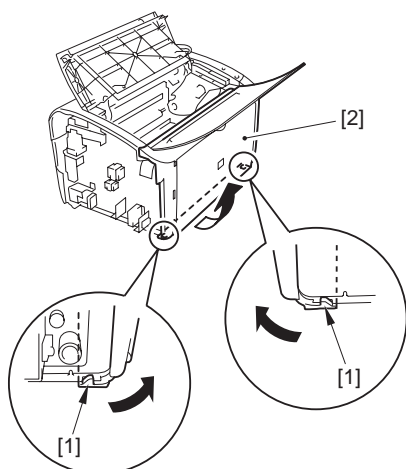

F-3-126

3.5.2.4 Removing the Upper Cover

0008-3602

- 1) Free the link stop [2] from the door link [1].
- 2) Remove the 2 screws [3].

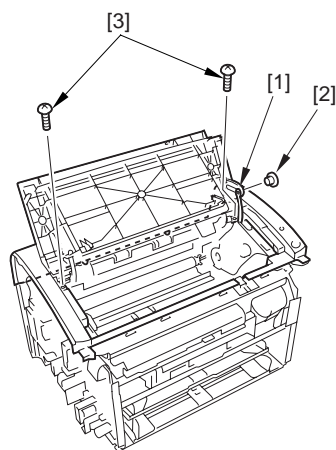

F-3-127

- 3) Slide the upper cover [1] in the direction of the arrow.
- 4) Remove the 2 claws [2] of the upper cover, and detach the cover.

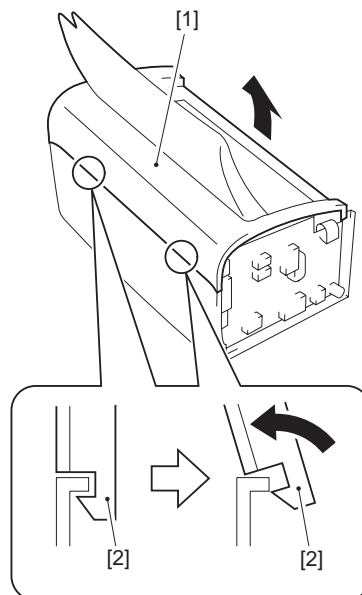

F-3-128



When mounting the upper cover, be sure to fit the 2 hooks [2] used to release the fixing assembly in the 2 hook holes [1] found in the cover.

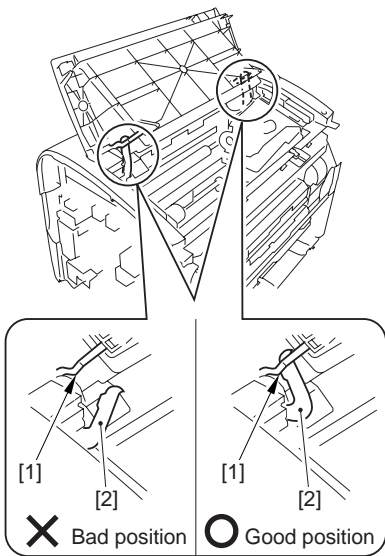

F-3-129

3.5.2.5 Removing the Rear Cover

0008-3608

1) Slide the rear cover [1] in the direction of the arrow to detach.

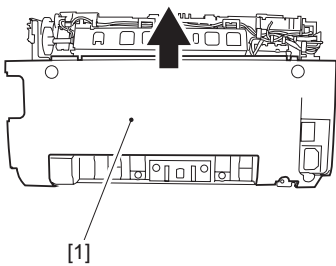

F-3-130

3.5.2.6 Removing the Power Supply PCB

0009-2769

- 1) Disconnect the flat cable [1].
- 2) Disconnect the 4 connectors [2], and free the harness [4] from the harness guide [3].

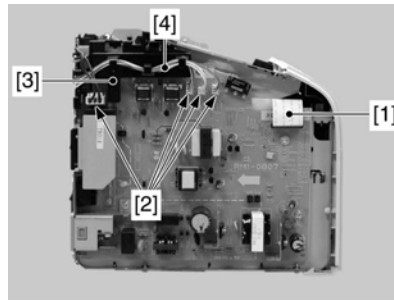

F-3-131

- 3) Disconnect the high-voltage connector [1].
- 4) Remove the 6 screws [2], and detach the power supply PCB [3].

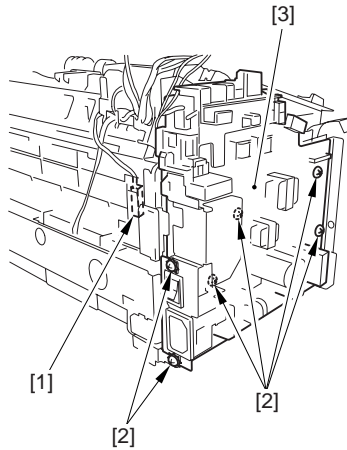

F-3-132

3.5.2.7 Removing the Fixing Assembly

0008-3605

- 1) Remove the 3 screws [1], and detach the fixing assembly [2].

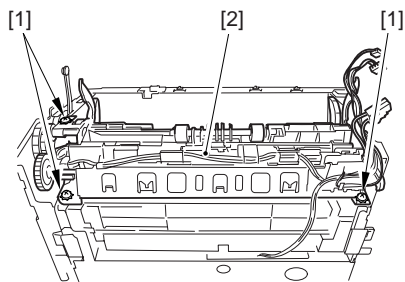

F-3-133

3.5.2.8 Removing the Fixing Film Unit

0008-1087

- 1) Free the harness [2] from the harness guide [1].

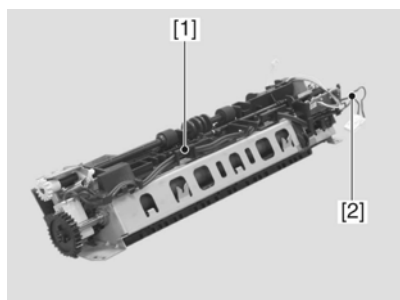

F-3-134

- 2) Remove the 2 screws [1], and detach the fixing cover [2].

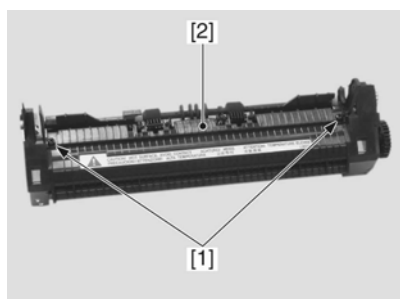

F-3-135

- 3) Remove the 2 springs [1], and detach the 2 releasing levers [2].
- 4) Remove the 2 locking plate [3], and detach the fixing film unit [4].

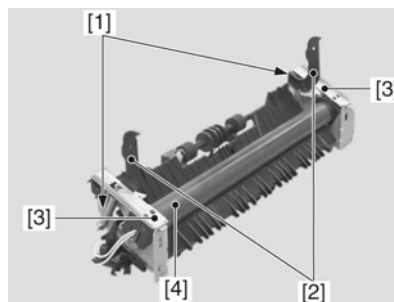

F-3-136

3.5.3 Fixing Pressure Roller

3.5.3.1 Removing the Right Cover

0008-3593

- 1) Open the delivery tray [1].
- 2) Open the upper cover [2].
- 3) Remove the screw [3].
- 4) Remove the 4 claws [4], and slide the right cover [5] in the direction of the arrow.

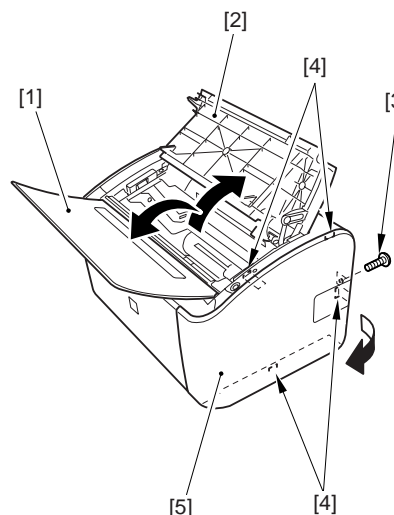

F-3-137

- 5) Remove the 3 claws [1], and slide the right cover [2] in the direction of the arrow to detach.

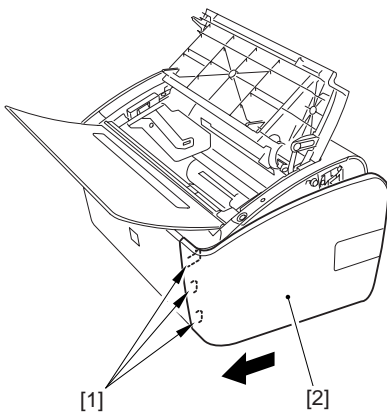

F-3-138

3.5.3.2 Removing the Left Cover

0008-3597

- 1) Open the delivery tray [1].
- 2) Open the upper cover [2].
- 3) Remove the screw [3].
- 4) Remove the 4 claws [4], and slide the left cover [5] in the direction of the arrow.

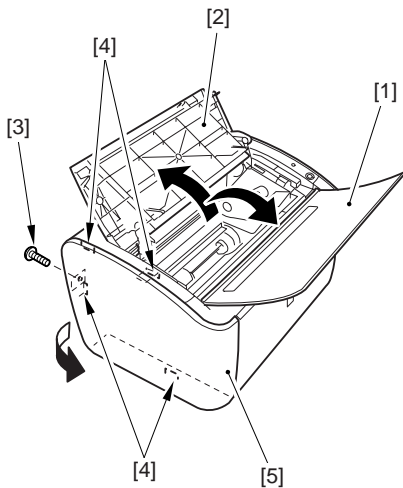

F-3-139

- 5) Remove the 3 claws [1], and slide the left cover [2] in the direction of the arrow to detach.

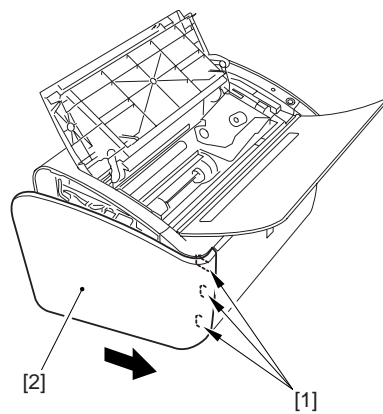

F-3-140

3.5.3.3 Removing the Front Cover

0008-3600

- 1) Remove the 2 claws [1].
- 2) Slide the front cover [2] in the direction of the arrow to detach.

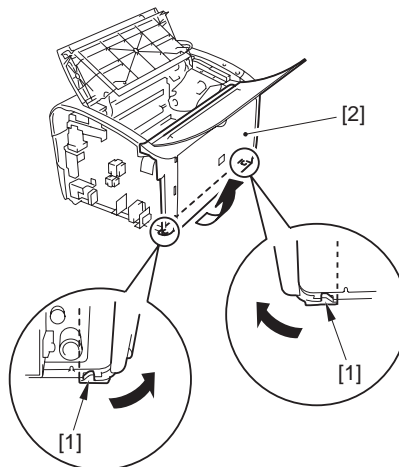

F-3-141

3.5.3.4 Removing the Upper Cover

0008-3603

- 1) Free the link stop [2] from the door link [1].
- 2) Remove the 2 screws [3].

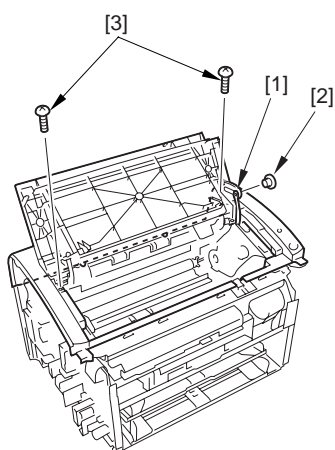

F-3-142

3) Slide the upper cover [1] in the direction of the arrow.

4) Remove the 2 claws [2] of the upper cover, and detach the cover.

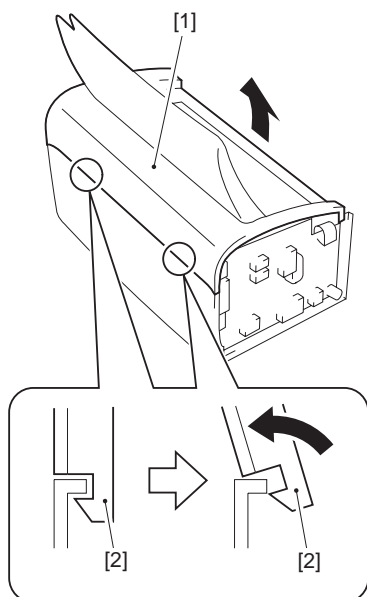

F-3-143



When mounting the upper cover, be sure to fit the 2 hooks [2] used to release the fixing assembly in the 2 hook holes [1] found in the cover.

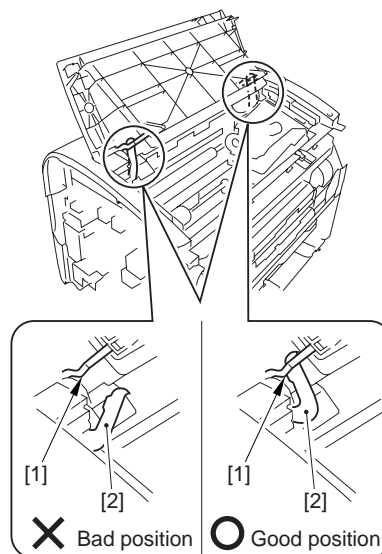

F-3-144

3.5.3.5 Removing the Rear Cover

0008-3609

1) Slide the rear cover [1] in the direction of the arrow to detach.

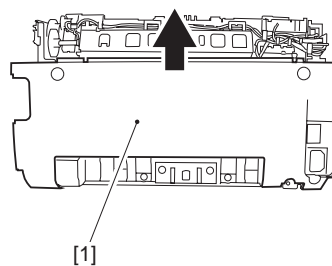

F-3-145

3.5.3.6 Removing the Power Supply PCB

0009-2770

1) Disconnect the flat cable [1].
 2) Disconnect the 4 connectors [2], and free the harness [4] from the harness guide [3].

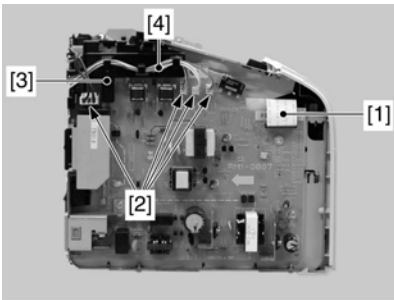

F-3-146

- 3) Disconnect the high-voltage connector [1].
- 4) Remove the 6 screws [2], and detach the power supply PCB [3].

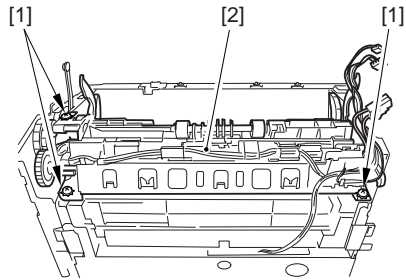

F-3-148

3.5.3.8 Removing the Fixing Film Unit

0008-3611

- 1) Free the harness [2] from the harness guide [1].

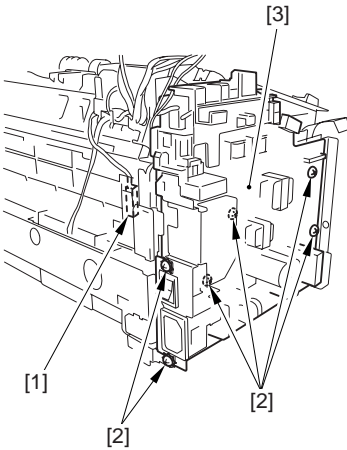

F-3-147

3.5.3.7 Removing the Fixing Assembly

0008-3606

- 1) Remove the 3 screws [1], and detach the fixing assembly [2].

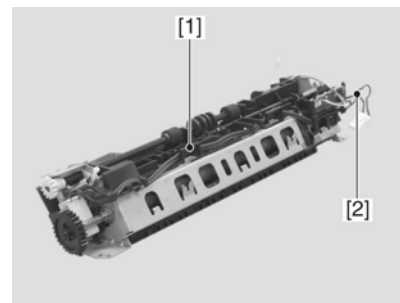

F-3-149

- 2) Remove the 2 screws [1], and detach the fixing cover [2].

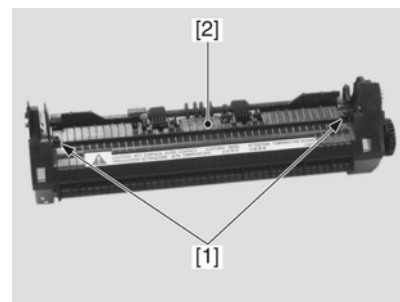

F-3-150

- 3) Remove the 2 springs [1], and detach the 2 releasing levers [2].
- 4) Remove the 2 locking plate [3], and detach the fixing film unit [4].

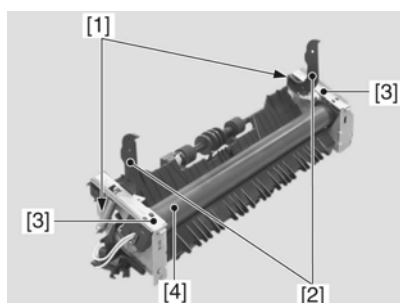

F-3-151

3.5.3.9 Removing the Pressure Roller

0008-1092

1) Remove the claw [1] and the gear [2]; then, detach the pressure roller [3].

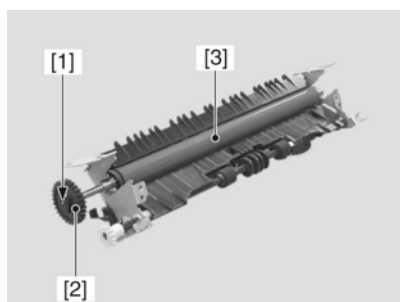

F-3-152

3.5.4 Delivery Sensor

3.5.4.1 Removing the Right Cover

0008-3594

1) Open the delivery tray [1].
 2) Open the upper cover [2].
 3) Remove the screw [3].
 4) Remove the 4 claws [4], and slide the right cover [5] in the direction of the arrow.

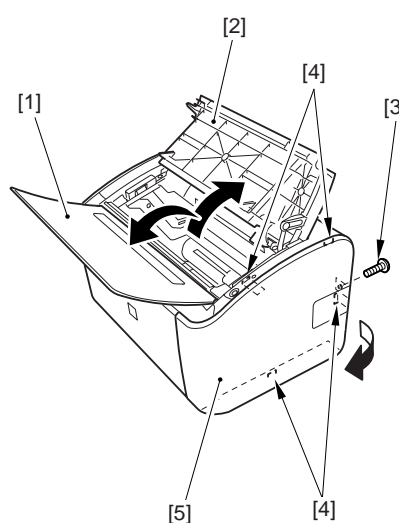

F-3-153

5) Remove the 3 claws [1], and slide the right cover [2] in the direction of the arrow to detach.

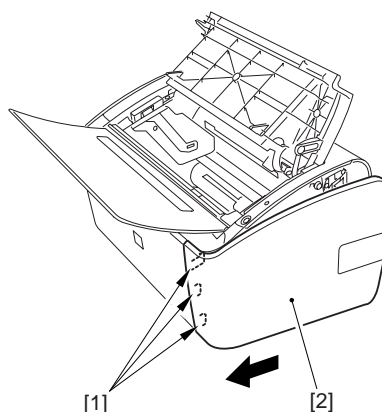

F-3-154

3.5.4.2 Removing the Left Cover

0008-3598

1) Open the delivery tray [1].
 2) Open the upper cover [2].
 3) Remove the screw [3].
 4) Remove the 4 claws [4], and slide the left cover [5] in the direction of the arrow.

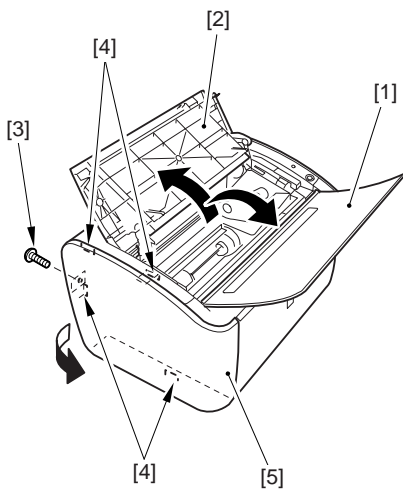

F-3-155

5) Remove the 3 claws [1], and slide the left cover [2] in the direction of the arrow to detach.

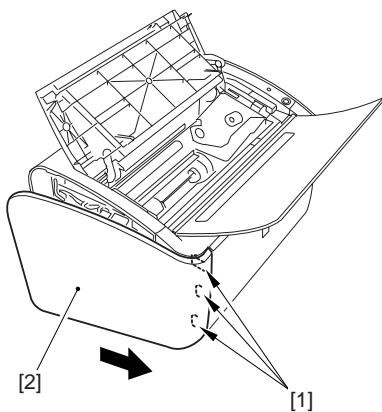

F-3-156

3.5.4.3 Removing the Front Cover

0008-3601

- 1) Remove the 2 claws [1].
- 2) Slide the front cover [2] in the direction of the arrow to detach.

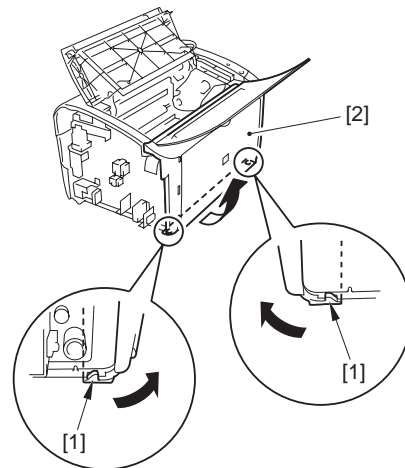

F-3-157

3.5.4.4 Removing the Upper Cover

0008-3604

- 1) Free the link stop [2] from the door link [1].
- 2) Remove the 2 screws [3].

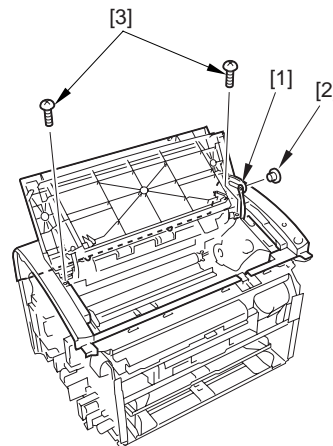

F-3-158

- 3) Slide the upper cover [1] in the direction of the arrow.
- 4) Remove the 2 claws [2] of the upper cover, and detach the cover.

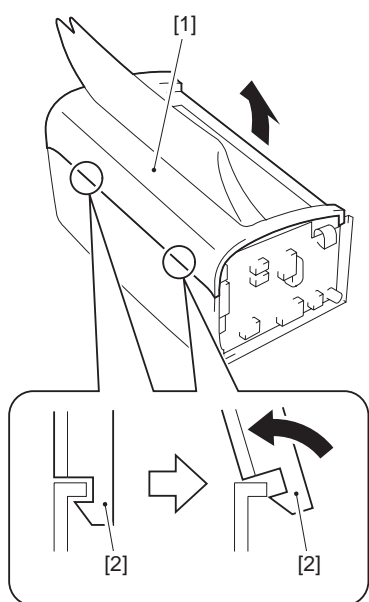

F-3-159



When mounting the upper cover, be sure to fit the 2 hooks [2] used to release the fixing assembly in the 2 hook holes [1] found in the cover.

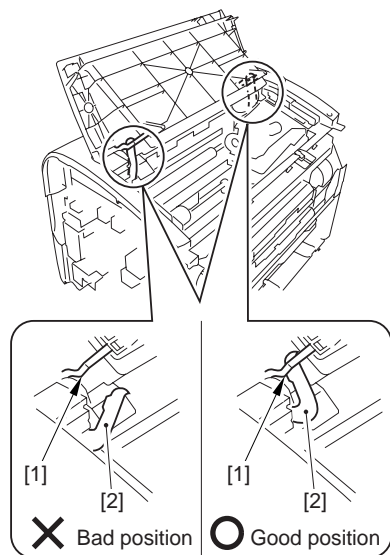

F-3-160

3.5.4.5 Removing the Rear Cover

0008-3607

1) Slide the rear cover [1] in the direction of the arrow to detach.

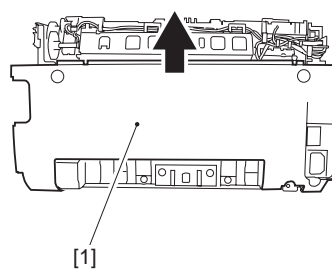

F-3-161

3.5.4.6 Removing the Delivery Sensor

0008-1094

1) Disconnect the connector [1], and free the harness [3] from the harness guide [2].

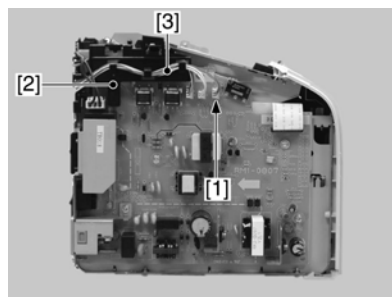

F-3-162

2) Remove the 2 claws [1], and detach the delivery sensor [2].

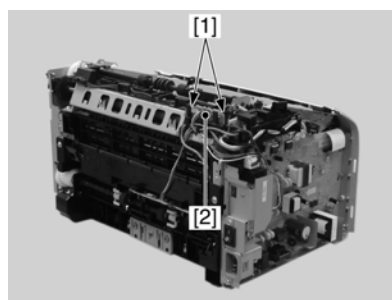

F-3-163

Chapter 4 MAINTENANCE AND INSPECTION

Contents

4.1 Periodically Replaced Parts	4-1
4.1.1 Periodic Replacement Parts	4-1
4.2 Consumables	4-2
4.2.1 Consumable Parts	4-2
4.3 Periodical Service	4-3
4.3.1 Periodic Service	4-3
4.4 Cleaning.....	4-4
4.4.1 Items to Clean.....	4-4
4.4.2 Cleaning (external covers).....	4-4
4.4.3 Cleaning (printer unit)	4-5

4.1 Periodically Replaced Parts

4.1.1 Periodic Replacement Parts

0008-0559

No parts require periodic replacement in this printer.

4.2 Consumables

4.2.1 Consumable Parts

0008-0561

No parts require consumables in this printer.

4.3 Periodical Service

4.3.1 Periodic Service

0008-0562

The printer has no parts that require periodic servicing.

4.4 Cleaning

4.4.1 Items to Clean

0008-0656

T-4-1

Items to clean	Timing of cleaning
External covers	when soiled
Pickup roller	when the performance of pickup has dropped
Separation pad	when the performance of the pad has dropped
Feed roller	when the performance of the roller has dropped
Transfer charging roller	when the back of paper becomes soiled; or, when a dropout (white spot) appears at intervals of about 146 mm in images
Static eliminator	when a polka dot pattern appears in images
Fixing inlet guide	when paper becomes soiled; when a black line appears in vertical direction at random intervals; when paper jams occur; when paper wrinkles



At the start of cleaning work, be sure to turn off the power and disconnect the power plug. Otherwise, a fire hazard or electric shock will be a possibility.

4.4.2 Cleaning (external covers)

0008-0658

Moisten a soft cloth with water or a solution of mild detergent, and wipe off the dirt. (Be sure that the cloth is well wrung.)

If you have used detergent, be sure to wipe off its residue using a soft cloth moistened with water (well wrung).

After removing the dirt, dry wipe the area with a soft cloth.

4.4.3 Cleaning (printer unit)

0008-0659

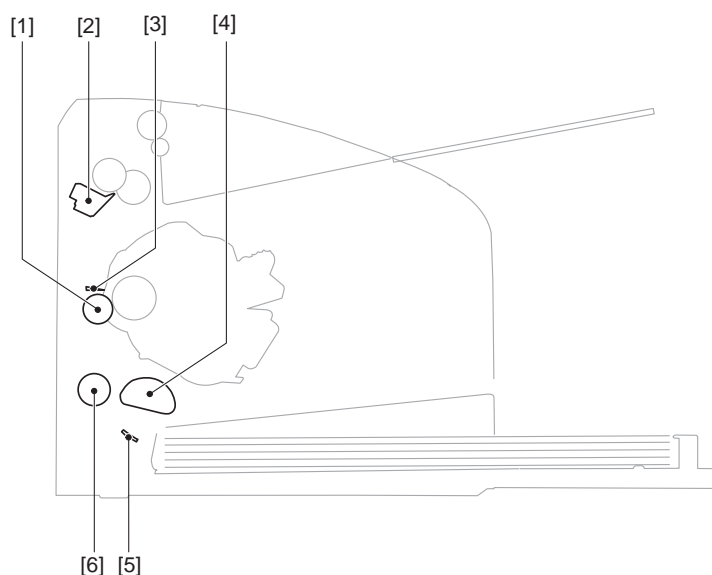

F-4-1

Be sure to follow the instructions given below when cleaning the components as part of service work:

[1] Transfer Charging Roller

As a rule, do not touch or clean the part. If absolutely necessary, be sure to take full care not to touch the roller and bring solvent or oil into contact with the roller.

Cleaning must be dry-wiping with lint-free paper. Never use water or solvent.

[2] Fixing Inlet Guide

Dry wipe with lint-free paper.

[3] Static Eliminator

Clean with a brush.

[4] Pickup Roller

Dry wipe with lint-free paper.

[5] Separation Pad

Dry wipe the rubber portion with lint-free paper.

[6] Feed Roller

Dry wipe with lint-free paper.



- * Do not touch the sponge portion of the transfer charging roller. Otherwise, the back of paper may become soiled or the image may suffer dropouts (white spots).
 - * Never use solvent.
 - * If the use of lint-free paper fails to remove dirt or the roller is deformed, replace
-

Chapter 5 TROUBLESHOOTING

Contents

5.1 Countermeasures	5-1
5.1.1 Image Faults	5-1
5.1.1.1 Partially Blank/Streaked	5-1
5.1.1.1.1 Image Faults Occurring at Specific Intervals	5-1
5.1.1.1.2 Smudged/Streaked	5-1
5.1.1.1.2.1 Image Fault Caused by Soiling of the Fixing Assembly	5-1
5.1.1.1.3 Ghost / Memory	5-2
5.1.1.1.3.1 Initial Offset in a Low Temperature/Humidity Environment	5-2
5.1.1.1.3.2 Black Lines Caused by Drum Memory	5-3
5.2 MEASUREMENT AND ADJUSTMENT	5-5
5.2.1 Mechanical Adjustment	5-5
5.2.1.1 Checking the Pressure of the Pressure Roller (nip)	5-5
5.3 SERVICE TOOLS	5-6
5.3.1 Special Tools	5-6
5.3.2 Solvent/Oil List	5-6
5.4 Location of Convector	5-7
5.4.1 Location of Convector	5-7
5.5 ERROR CODE TABLE	5-8
5.5.1 Overview	5-8
5.5.2 Service Messages	5-8

5.1 Countermeasures

5.1.1 Image Faults

5.1.1.1 Partially Blank/Streaked

5.1.1.1.1 Image Faults Occurring at Specific Intervals

0008-1391

Description

The fault occurs in main scanning direction.

Field Remedy

Refer to the following table to identify a specific roller or component. Then, clean or replace the roller or component:

T-5-1

Interval (mm; approx)	Roller or component
55	Feed roller
46	Transfer charging roller
38	Primary charging roller
76	Photosensitive drum
31	Developing cylinder
57	Fixing film unit
56	Pressure roller

5.1.1.2 Smudged/Streaked

5.1.1.2.1 Image Fault Caused by Soiling of the Fixing Assembly

0009-1225

Cause

When the machine has been used for a long time, its fixing assembly is likely to have become worn, readily allowing residual toner to stick to the fixing film or the pressure roller and, ultimately, soiling print images.

Field Remedy

Execute "clean fixing assembly" using the printer driver as follows:

- 1) Place an A4 or LTR blank sheet of paper in the pickup tray or the manual feed tray.

- 2) Bring up the Printer Status screen.
- 3) From the Options menu, select "cleaning".

Supplementary Information

This symptom may not disappear after a single session of cleaning. If such is the case, execute cleaning once again. If it still remains after executing cleaning multiple times, replacement of the fixing assembly is recommended.

Image Sample

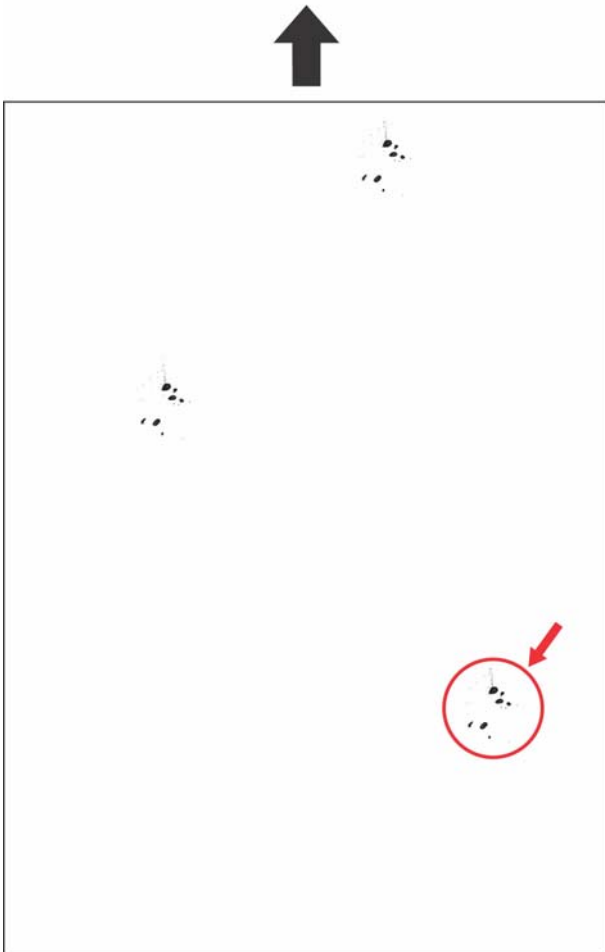

F-5-1

5.1.1.3 Ghost / Memory

5.1.1.3.1 Initial Offset in a Low Temperature/Humidity Environment

0009-1221

Cause

When a machine is shipped from the factory, the inside of its fixing film unit is coated with grease to facilitate sliding. When prints are made in a low temperature/humidity environment immediately after the machine is turned on, however, the grease can fail to soften and spread evenly.

As a result, the fixing film unit tends to become partially heated, causing offset images.

Field Remedy

Set the printer driver as follows:

- * For "paper type" under "pickup", select "plain paper L".

Reference Information

The foregoing driver setting is valid when plain paper is used. If paper is not plain paper, avoid changing the driver setting.

Supplementary Information

- * This symptom is limited to immediately after the machine is put into use. In other words, the machine will be free of the symptom once it has been used for a time.
- * This symptom occurs in keeping with the fixing film rotation or the pressure roller rotation (i.e., 56 to 57 mm).

Image Sample

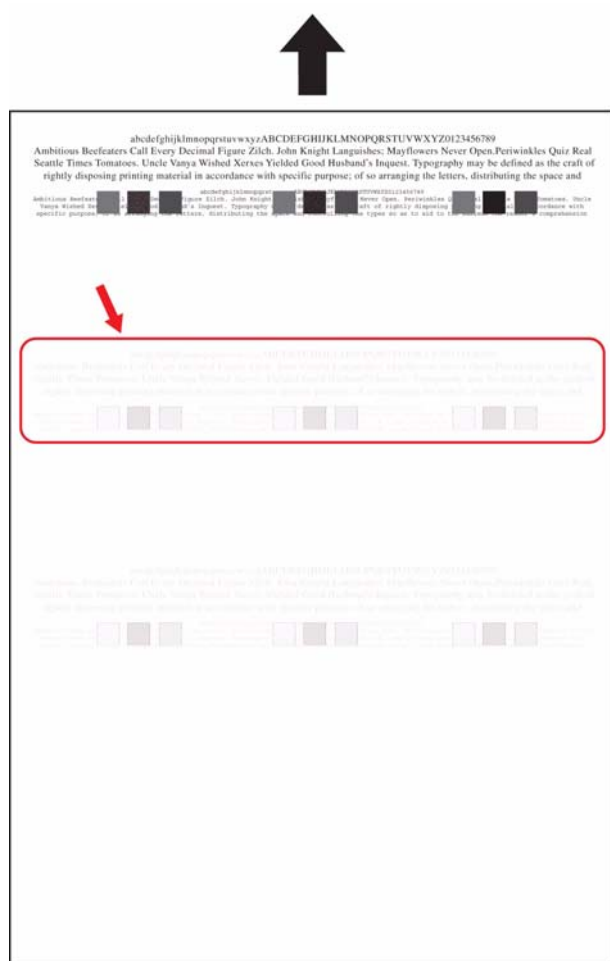

F-5-2

5.1.1.3.2 Black Lines Caused by Drum Memory

0009-1229

Cause

When the drum cartridge is being transported, friction that may occur between the drum and the primary charging

roller inside it can cause electric changes, leaving positive charges on the drum. When printing is executed in a low temperature/humidity environment, these charges can cause horizontal black lines on the drum.

Field Remedy

Make about 5 to 10 prints; then, leave the machine in the office environment (normal temperature/humidity conditions) for 2 hr or so.

Supplementary Information

* This symptom is noticeable in a low temperature/humidity environment, and is absent under normal environmental conditions.

* This symptom occurs in keeping with the primary charging roller rotation (38 mm).

Image Sample

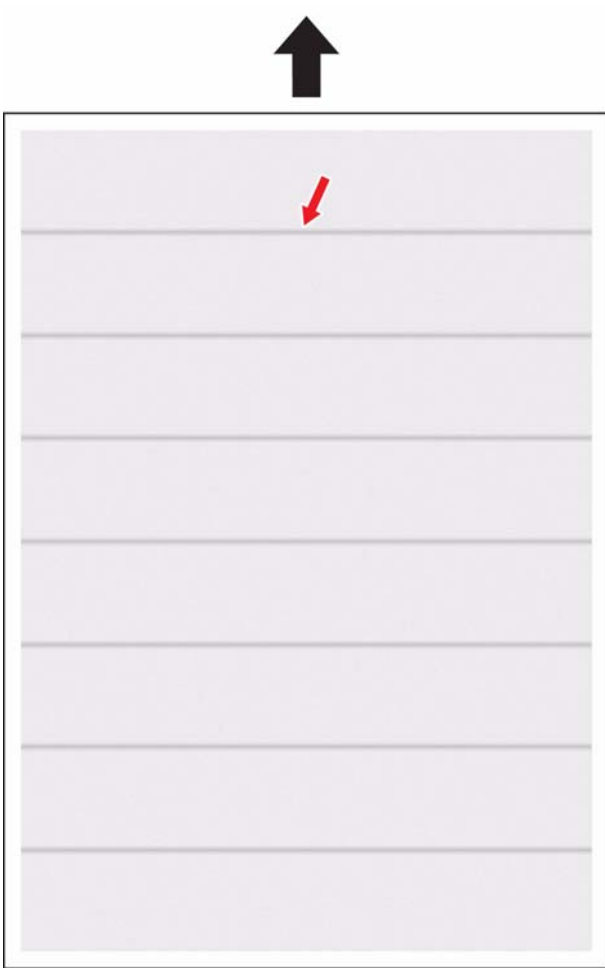

F-5-3

5.2 MEASUREMENT AND ADJUSTMENT

5.2.1 Mechanical Adjustment

5.2.1.1 Checking the Pressure of the Pressure Roller (nip) 0008-0569

The machine's fixing assembly does not permit adjustment of its nip. The wrong nip, however, can cause fixing faults, requiring a check as follows:

1. Take a solid black printout to the user's. (Use the EP cartridge and A4 print paper for the printout.)
2. With the printed face of the solid black print paper facing downward, place it in the machine's manual feed tray.
3. Make a text print.
4. When the leading edge of the print paper starts to appear in the face-down delivery slot, turn off the power.

About 60 sec after you have turned off the power, open the upper cover and pull out the print paper from the machine.

5. Measure the area of the toner on the print paper the its shiny, and check to make sure that it is as indicated:

* center (a): 6.2 to 6.4 mm

* left/right (b, c): 6.7 to 6.9 mm

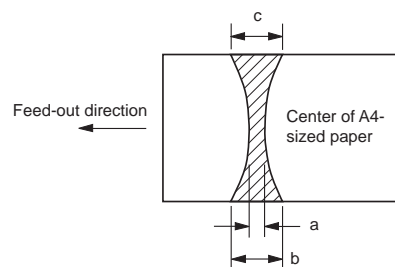

F-5-4

5.3 SERVICE TOOLS

5.3.1 Special Tools

0008-0564

The machine requires no special tools that must be used in addition to its standard set of tools.

5.3.2 Solvent/Oil List

0008-0975

T-5-2

No.	Name	Use	Components	Remarks
1	Alcohol	Cleaning: plastic (note), rubber, metal, oil, and toner stains	Alcohol	-Flammable: keep away from flame -Purchase locally
2	Lubricant	Apply to gears, between shaft and bushing	Special oil Special solid lubricating material Lithium soap	-Tool No. HY9-0007
3	Lubricant	Apply between pressure roller shaft and grounding plate	High performance grease Carbon black Graphite	-Electricity grease -Tool No. CK-8007



When cleaning the external covers, use a firmly squeezed wet cloth.

5.4 Location of Connectors

5.4.1 Location of Connectors

0009-4697

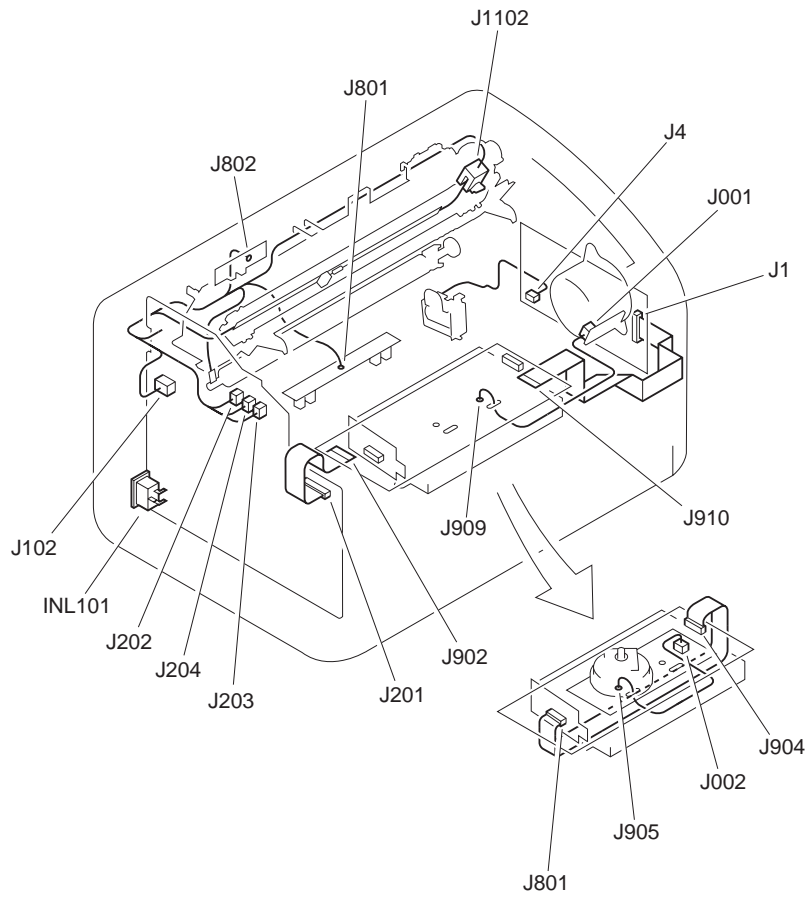

F-5-5

5.5 ERROR CODE TABLE

5.5.1 Overview

0008-0664

The printer unit does not have a display panel (LCD) for status indication, and all messages needed to indicate printer operation (status, error) appear on a PC display using a screen called "status window."

The status window is a window designed to communicate to the user the status of the machine by means of messages and animations.

The messages appear in the message area [1] and the sub message area [2], and a message may be a user message or a service message; the former is used to prompt the user to take a specific action, while the latter is mat for a service person.

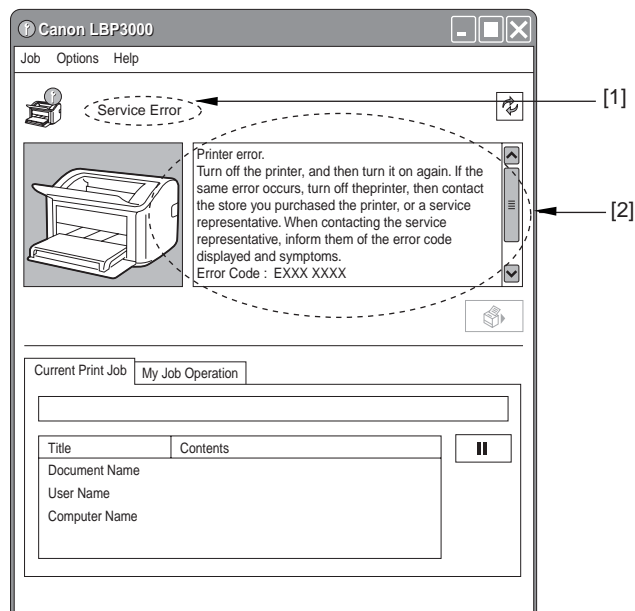

F-5-6

The service messages are described below; for user messages, refer to the User Guide that comes with the printer unit:

5.5.2 Service Messages

0008-0665

A service message will be indicated in response to a fault in the printer unit, and is also called an error code.

An error code is indicated in the message area of the status window, and its detail code (Exxx, xxx being 3 numerals) is indicated in the sub message area.

T-5-3

Error code	Major cause/detection	Remedy
E000	The thermistor has an open circuit or a short circuit.	<ul style="list-style-type: none"> - Check the connector of the fixing film unit. - Replace the fixing film unit. - Replace the power supply PCB. - Replace the engine controller PCB.
	The heater has an open circuit. The thermal fuse has blown.	
	The power supply PCB has a fault.	
	The engine controller PCB has a fault.	
E100	The scanner assembly has a fault.	<ul style="list-style-type: none"> - Check the connector of the laser scanner assembly. - Replace the laser scanner assembly. - Replace the engine controller PCB.
E197	There is an engine communication error.	<ul style="list-style-type: none"> - Replace the engine controller PCB.
E747	There is a fault in the video controller memory.	<ul style="list-style-type: none"> - Replace the video controller PCB.

Chapter 6 APPENDIX

Contents

6.1 OUTLINE OF ELECTRICAL COMPONENTS	6-1
6.1.1 Clutch/Solenoid	6-1
6.1.1.1 Solenoid	6-1
6.1.2 Motor	6-1
6.1.2.1 Motor	6-1
6.1.3 Sensor	6-2
6.1.3.1 Sensor	6-2
6.1.4 Switch	6-3
6.1.4.1 Switch	6-3
6.1.5 Lamps, Heaters, and Others	6-4
6.1.5.1 Heater	6-4
6.1.6 PCBs	6-5
6.1.6.1 PCBs	6-5

6.1 OUTLINE OF ELECTRICAL COMPONENTS

6.1.1 Clutch/Solenoid

6.1.1.1 Solenoid

0008-0929

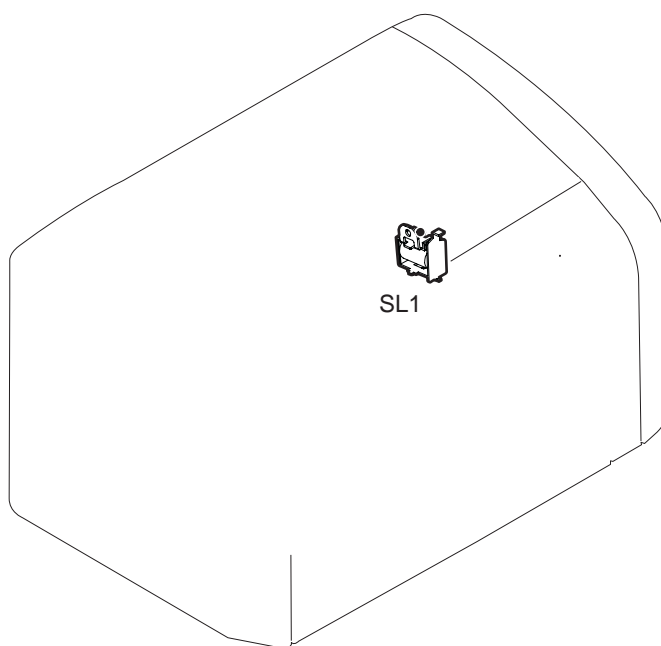

F-6-1

T-6-1

Notation	Name
SL1	Pickup solenoid

6.1.2 Motor

6.1.2.1 Motor

0008-0935

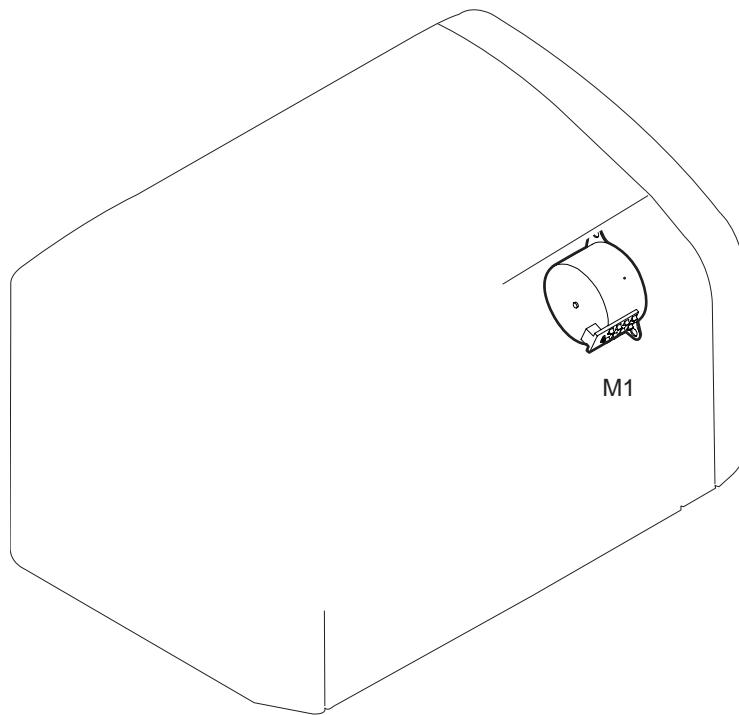

F-6-2

T-6-2

Notation	Name
M1	Main motor

6.1.3 Sensor

6.1.3.1 Sensor

0008-0938

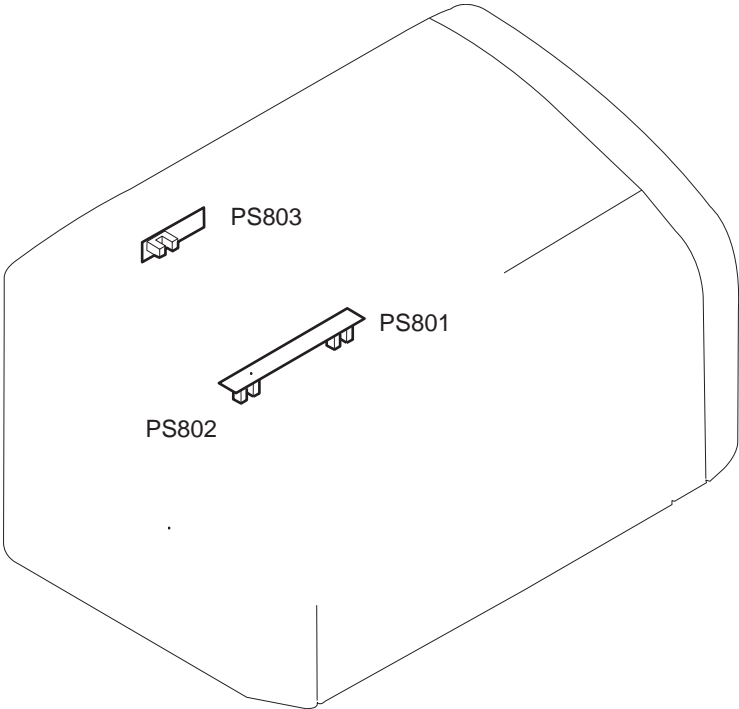

F-6-3

T-6-3

Notation	Name
PS801	Top of page sensor
PS802	Paper width sensor
PS803	Paper delivery sensor

6.1.4 Switch

6.1.4.1 Switch

0008-0939

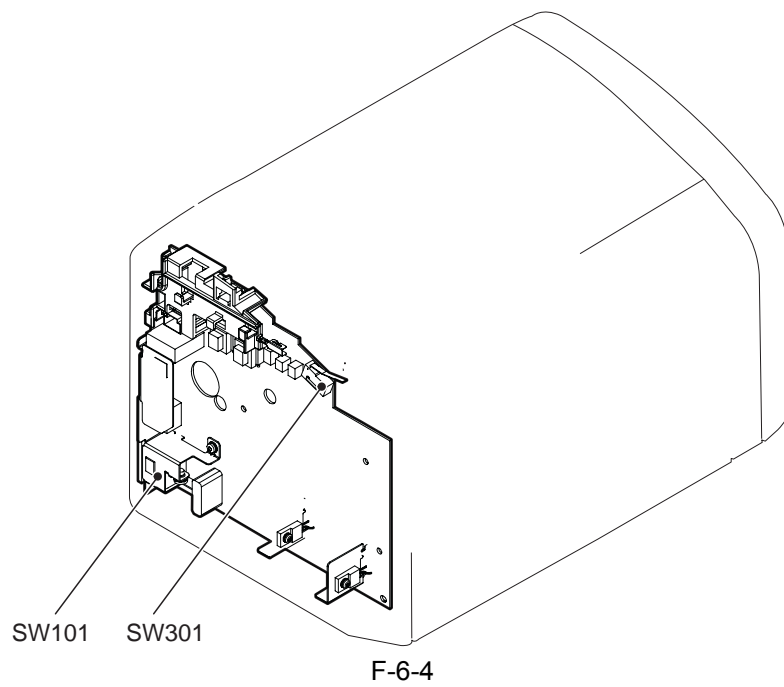

F-6-4

T-6-4

Notation	Name
SW101	Power switch
SW301	Door switch

6.1.5 Lamps, Heaters, and Others

6.1.5.1 Heater

0008-0941

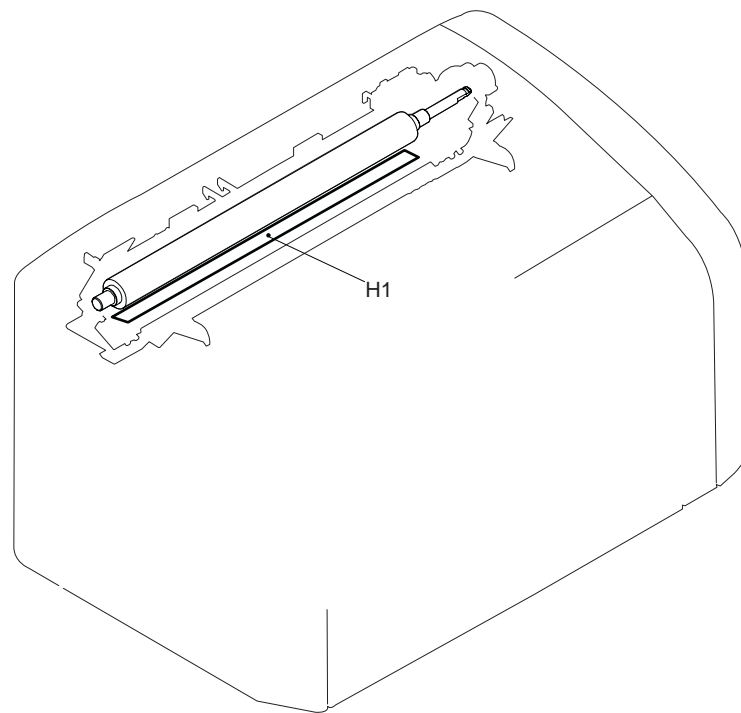

F-6-5

T-6-5

Notation	Name
H1	Fixing heater

6.1.6 PCBs

6.1.6.1 PCBs

0008-0943

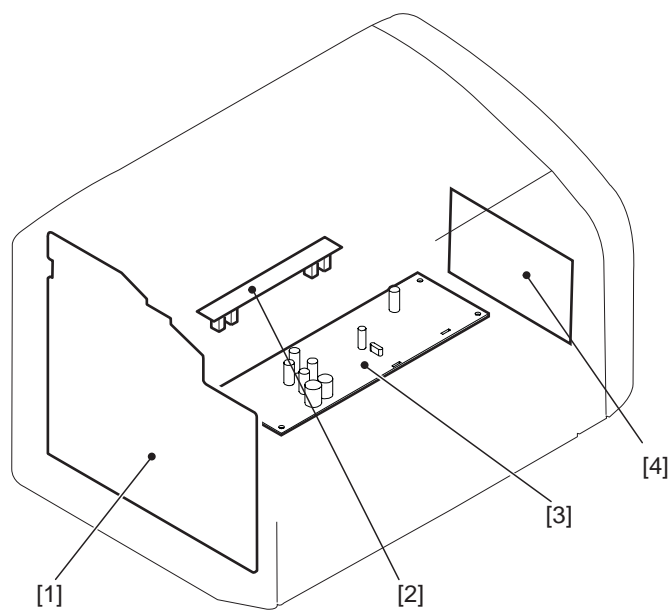

F-6-6

T-6-6

No.	Name
[1]	Power supply PCB
[2]	Top of Page/Paper Width Sensor PCB
[3]	Engine controller PCB
[4]	Video controller PCB

Feb 23 2005

Canon