

PIXMA MP760

SERVICE MANUAL

Canon

PIXMA MP760

SERVICE MANUAL

REVISION 0

| | | |
|-------------|----------|----------|
| PIXMA MP760 | H12-4602 | 120V USA |
| PIXMA MP760 | H12-4603 | 230V EMB |
| PIXMA MP760 | H12-4604 | 230V GB |
| PIXMA MP760 | H12-4605 | 230V EUM |
| PIXMA MP760 | H12-4606 | 120V CND |
| PIXMA MP760 | H12-4608 | 230V AUS |
| PIXMA MP760 | H12-4609 | 230V AE |

Scope

This manual has been issued by Canon Inc., to provide the service technicians of this product with the information necessary for qualified persons to learn technical theory, installation, maintenance, and repair of products. The manual covers information applicable in all regions where the product is sold. For this reason, it may contain information that is not applicable to your region.

Revision

This manual could include technical inaccuracies or typographical errors due to improvements or changes made to the product. When changes are made to the contents of the manual, Canon will release technical information when necessary. When substantial changes are made to the contents of the manual, Canon will issue a revised edition.

The following do not apply if they do not conform to the laws and regulations of the region where the manual or product is used:

Trademarks

Product and brand names appearing in this manual are registered trademarks or trademarks of the respective holders.

Copyright

All rights reserved. No parts of this manual may be reproduced in any form or by any means or translated into another language without the written permission of Canon Inc., except in the case of internal business use.

Copyright © 2004 by Canon Inc.

CANON INC.

Inkjet MFP/FAX Quality Assurance Div.

5-1 Hakusan 7-Chome, Toride-city, Ibaraki 302-8501, Japan

I. MANUAL OUTLINE

This manual consists of the following three parts to provide information necessary to service the PIXMA MP760:

Part 1: Maintenance

Information on maintenance and troubleshooting of the PIXMA MP760

Part 2: Technical Reference

New technology and technical information such as FAQ's (Frequently Asked Questions) of the PIXMA MP760

Part 3: Appendix

Block diagrams and pin layouts of the PIXMA MP760

Reference:

This manual does not provide sufficient information for disassembly and reassembly procedures. Refer to the graphics in the separate Parts Catalog.

II. TABLE OF CONTENTS

Part 1: MAINTENANCE

| | |
|--------|--|
| 1 - 1 | 1. MAINTENANCE |
| 1 - 1 | 1-1. Adjustment, Periodic Maintenance, Periodic Replacement Parts, and Replacement Consumables by Service Engineer |
| 1 - 3 | 1-2. Customer Maintenance |
| 1 - 3 | 1-3. Product Life |
| 1 - 4 | 1-4. Special Tools |
| 1 - 5 | 1-5. Serial Number Location |
| 1 - 6 | 2. LIST OF ERROR DISPLAY / INDICATION |
| 1 - 6 | 2-1. Users Error Messege |
| 1 - 9 | 2-2. New Error Codes and Recovery Methods |
| 1 - 11 | 2-3. Warnings |
| 1 - 11 | 2-4. Troubleshooting by Symptom |
| 1 - 16 | 3. REPAIR |
| 1 - 16 | 3-1. Notes on Service Part Replacement (and Disassembling / Reassembling) |
| 1 - 19 | 3-2. Special Notes on Repair Servicing |
| 1 - 19 | 3-2-1 Flexible Cable and Harness Wiring, Connection |
| 1 - 21 | 3-3. Adjustment / Settings |
| 1 - 21 | 3-3-1 Paper Feed Motor Adjustment |
| 1 - 22 | 3-3-2 Gear Phase Adjustment |
| 1 - 24 | 3-3-3 Lift Cam Shaft Ass'y Adjustment |
| 1 - 25 | 3-3-4 Solenoid Cam Spring Location |
| 1 - 25 | 3-3-5 Carriage Shaft Clip Location |
| 1 - 26 | 3-3-6 White Sheet Location |
| 1 - 28 | 3-3-7 Grease Application |
| 1 - 30 | 3-3-8 Waste Ink Counter Setting |
| 1 - 30 | 3-4. User Data Flow |
| 1 - 33 | 3-5. Service Switches |
| 1 - 33 | 3-5-1 Hardware Switches |
| 1 - 33 | 3-5-2 Service Data Setting |
| 1 - 34 | 3-5-3 Service Data Registration / Setting Method |
| 1 - 35 | 3-5-4 Service Data Flowchart |
| 1 - 39 | 3-5-5 Explanation of service data |
| 1 - 40 | 3-5-6 New SSSWs / parameters added to this model |
| 1 - 42 | 3-5-7 SSSW Default Setting |
| 1 - 60 | 3-6. Test Mode / Factory Mode |
| 1 - 60 | 3-6-1 Test Mode / Factory Mode Overview |
| 1 - 61 | 3-6-2 Test Mode Menu |
| 1 - 62 | 3-6-3 Factory Mode |
| 1 - 63 | 3-6-4 Operation Panel Test |
| 1 - 64 | 3-6-5 Print Test |
| 1 - 66 | 3-6-6 CD-R Calibration (230V only) |
| 1 - 66 | 3-6-7 IRDA test |
| 1 - 66 | 3-7. Upgrading the version of SPCNT Flash ROM |
| 1 - 67 | 3-8. Verification Items |

| | |
|--------|------------------------------------|
| 1 - 67 | 3-8-1 EEPROM information print |
| 1 - 69 | 4. Cleaning Your Machine |
| 1 - 69 | 4-1 Caution |
| 1 - 69 | 4-2 Cleaning the Exterior |
| 1 - 69 | 4-3 Cleaning the Scan area |
| 1 - 70 | 4-4 Cleaning the Interior |
| 1 - 70 | 4-5 Cleaning the Paper Feed Rollor |
| 1 - 71 | 4-6 Cleaning the Bottom Plate |
| 1 - 72 | 5. Transportation |

Part 2: TECHNICAL REFERENCE

| | |
|-------|--|
| 2 - 1 | 1. New Technologies |
| 2 - 3 | 2. Cleaning Mode and Amount of Ink Purged |
| 2 - 5 | 3. Print Mode |
| 2 - 9 | 4. FAQ (Problems Specific to the MP760 and Corrective Actions) |

Part 3: APPENDIX

| | |
|-------|-------------------|
| 3 - 1 | 1. Wiring Diagram |
| 3 - 2 | 2. Specification |

Part 1

Maintenance

1. MAINTENANCE

1-1 Adjustment, Periodic Maintenance, Periodic Replacement Parts, and Replacement Consumables by Service Engineer

(1) Adjustment

| Adjustment | Timing | Purpose | Tool | Approx time |
|---|---|---|---|-------------|
| ALL CLEAR (EEPROM initialization) * 1 | At SPCNTBOARDASSY replacement | To initialize settings other than the following -Service/User soft SW -Various counter -TYPE Setting | None To initialize the settings, select # 8 CLEAR –ALL in the service mode | 1 min |
| TYPE settings (EEPROM settings) * 1 | -At SPCNTBOARDASSY replacement -At executing All clear | -To set the type -To set the destination | None Select # 5 TYPE in the service mode Power SW OFF/ON* 1 | 1 min |
| Waste ink counter resetting (EEPROM settings) | At bottom case unit replacement At ink absorber INK ABSORBER (HY7-2885/2886/2887/2888/2889/2890/2891/2953) | To reset the waste ink counter. | None Select # 7 PRINTER in the service mode, and input “ 0” at # 5 INK ABS CAPA. | 1min |
| Waste ink counter setting (EEPROM initialization) | At SPCNTBOARDASSY replacement | Waste ink counter setting | None Print out the EEPROM information, and select # 7 PRINTER in the service mode. Then, register at # 5 INK ABS CAPA. | 1 min |
| CD-R sensor / automatic print head alignment sensor correction (EEPROM settings) (230V only) | At SPCNTBOARDASSY replacement At carriage unit replacement | To correct the CD-R and automatic print head alignment sensor. | None. (Correction performed through FACTORY MODE-[2] PRINTER-SHUKKEN at the same time as printing.) | 1 min |

| Adjustment | Timing | Purpose | Tool | Approx time |
|--|--|--|---|-------------|
| Print head alignment | - At print head replacement - At SPCNTBOARDASS'Y replacement | To ensure accurate dot placement. | None.(Main body buttons) Computer (settings via the printer driver) | 2 min |
| Paper feed motor position adjustment* * 2 | At paper feed motor unit replacement | To adjust the belt tension. (Position the paper feed motor so that the belt is stretched tight.) | None For the adjustment, refer to [3-3 Adjustment/Settings (1) PAPER FEED MOTOR Installation Adjustment. | 2 min |
| Grease application | -At carriage unit replacement -At chassis' upper gear replacement -At LIFT CAM SHAFT replacement | -To maintain sliding properties of the carriage, carriage shaft, and shaft lift. -To protect the chassis' upper gear. -To LIFT CAM SHAFT replacement | -FLOIL KG-107A -MOLYKOTE HP300 | 1 min |

Note: DO NOT loosen the red screws on both sides of the main chassis, securing the carriage shaft positioning.

* 1: When SPCNT BOARD ASS'Y is replaced, be sure to select the settings of [# 8CLEAR] -[ALL] and [# 5TYPE] in Service Mode, and turn the power OFF/ON with the Power button (Software Power: OFF/ON). DO NOT turn the power OFF/ON by removing and inserting the power code (Hardware Power: OFF/ON). In this case, data may not be written correctly.

* 2: Red screws of paper feed motor
The red screws securing the paper feed motor may be loosened only at replacement of the paper feed motor unit.

(2) Periodic maintenance

| Adjustment | Timing | Purpose | Tool | Approx. time |
|------------|--------|---------|------|--------------|
| None | | | | |

(3) Periodic replacement parts

| Adjustment | Timing | Purpose | Tool | Approx. time |
|------------|--------|---------|------|--------------|
| None | | | | |

(4) Replacement consumables

| Adjustment | Timing | Purpose | Tool | Approx. time |
|------------|--------|---------|------|--------------|
| None | | | | |

1-2 Customer Maintenance

| Adjustment | Timing | Purpose | Tool | Approx. time |
|--------------------------------|--|-----------------------------------|---|--------------|
| Print head alignment | At print head replacement. | To ensure accurate dot placement. | None Main body buttons Computer (automatic settings via the printer driver) | 3min |
| Print head cleaning | When print quality is not satisfying. | To improve nozzle conditions. | None Main body buttons Computer (settings via the printer driver) | 1 min |
| Print head deep cleaning | When print quality is not satisfying, and not improved by print head cleaning. | To improve nozzle conditions. | None Computer (setting via the printer driver) | 2min |
| Ink tank replacement | When an ink tank becomes empty.(No ink error) | - | - | 2min |
| Paper feed roller cleaning | When paper does not feed properly. | To clean the paper feed rollers. | None Main body buttons | 2min |
| CD-R print position adjustment | At CD-R printing, when necessary | To correct CD-R print position. | None Computer (application software) | 2min |
| Bottom plate cleaning | When the back side of the paper is smeared | To clean the platen ribs. | None Computer (application software) | 1min |

1-3 Product Life

(1) Main body

Specified print volume (a), (b), or the years of use (c), whichever comes first.

(a) Scanning Section: 15,000 pages

(b) Printing Section: 18,000 pages

| | | Copy | Print |
|-------|---|-------------|-------------|
| Bk | 1,500 character pattern + Post card Address printing | 3,420 pages | 3,960 pages |
| | 1,500 character pattern | - | - |
| Color | A4, 7.5% duty per color pattern | 2,520 pages | 2,880 pages |
| | A4, photo, borderless printing | 180 pages | 360 pages |
| | L, photo, borderless printing | 1,080 pages | 1,980 pages |
| | Postcard, photo, borderless printing | 360 pages | 1,260 pages |

(c) Years of use

5 years of use

(2) Ink tank

| | | |
|-----------|-------------|--|
| BCI-3eBK: | 900 pages | (J EIDA STD patternJ 1, plain paper standerd mode) |
| | 740 pages | (Black 1,500 character pattern, plain paper / standard mode) |
| | 1,300 pages | (ISO J IS-SCID No. 5 / plain paper / standard mode) |
| BCI-6C: | 550 pages | (ISO J IS-SCID No. 5 / plain paper / standard mode) |
| BCI-6M: | 430 pages | (ISO J IS-SCID No. 5 / plain paper / standard mode) |
| BCI-6Y: | 360 pages | (ISO J IS-SCID No. 5 / plain paper / standard mode) |
| BCI-6BK: | 2,000 pages | (ISO J IS-SCID No. 5 / plain paper / standard mode) |

1-4 Special Tools

| Name | Tool No. | Application | Remarks |
|-------------------|--------------|---|---------------------------------|
| MOLYKOTE HP300 | CK-8012-000 | To be applied to the chassis' upper gear, and to the sliding portion of the shaft lift. | New |
| FLOIL KG-107A | QY9-0057-000 | To be applied to the sliding portion of the carriage and the bearing portion of the carriage shaft. | In common with other models. |

1-5 Serial Number Label Location

On the right side of the backside in the bottom case (close to the rating plate)

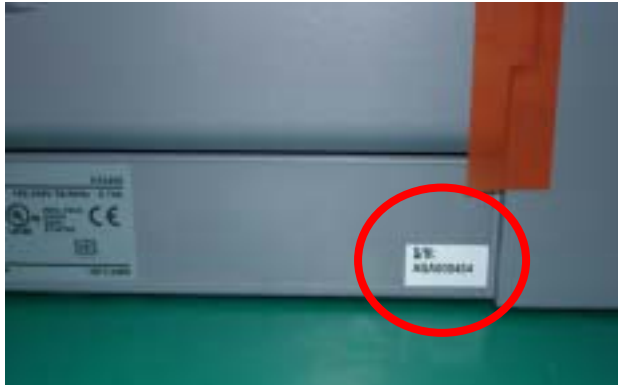

Figure1-1 Serial Number Label Location

2. LIST OF ERROR DISPLAY / INDICATION

User error messages

Look for the applicable error message and execute the appropriate countermeasures.

Error Codes

As for the causes and countermeasures, only the error codes that are newly incorporated in the unit remedies unique to the product are included in New Error Codes and Recovery Methods. For the causes and countermeasures of other error codes, refer to the separate G3/G4 Facsimile Error Code List (Rev. 2).

Service error code output

When service data # 1 SSSW SW01 Bit0 is set to " 1" the following service error codes are displayed when an error occurs.

2-1 User's error message

"Print head does not work. Clear foreign object from print head. Turn off and on"

Printing position correction failed

Cause: Carriage movement prevented by one of the following.

Damaged shaft.

Parts deformed. (Carriage or guide frame)

Insufficient grease.

Solution: Replace the shaft.

Replace the deformed parts.

Apply more grease.

Cause: Bi-directional print displacement correction failed because the carriage motor is out of step, or some similar reason.

Solution: Replace the carriage motor.

Home position error

Cause1: Tried to stop the carriage unit that has been moving or to move the carriage unit at a pause by force.

Solution1: Do not touch the carriage unit other than cartridge replacement position.

Cause2: Foreign body in carriage section.

Solution2: Open flatbed ass'y and remove the foreign body.

Cause3: Loose carriage belt.

Solution3: Replace carriage unit

Cause4: Carriage motor does not work.

Solution4 (1) Switch power OFF/ON.

(2) Replace carriage motor.

Cause5: The position of the carriage cannot be detected (due to smears on the carriage encoder film or SPCNT board failure).

Solution5: (1) Switch power off/on.

(2) Wipe the carriage encoder film with a cloth soaked with alcohol.

(3) Replace the carriage encoder film.

(4) Replace the SPCNT board.

Note:

This error message means the same as service error codes # # 338 and # # 340. When this error occurs in this model, it is not treated as a service error, but as a user error, and the error message is displayed.

“Scanning Unit (Printer Cover) is open.”

Cause: You opened the scanning unit (printer cover) during an operation.

Solution: Close the scanning unit (printer cover).

Cause: Damaged scanner open arm ass’y, damaged scanner sensor arm, or SPCNT board ass’y failure.

Solution: Replace the scanner open arm ass’y, replace the scanner sensor arm, or replace the SPCNT board ass’y.

“The paper is jammed. Clear the paper and press [OK].”

Cause: The paper is jammed.

Solution: Clear the paper and press [OK] .

“Error Turn the machine off and on”

Cause: The printer’s internal unit has malfunctioned.

Solution: Clear the paper.

Press [OK]

Reattachment the Print head.

Switch power off/on.

Check the service error code and refer to an appropriate solution.

“The machine's memory is full. Delete documents, or print from PC if the data is image.”

Cause: The machine’s memory is full because you tried to copy a very detailed document.

Solution: Divide the document and copy each part separately.

“Cannot write to memory card. (displayed as [write-protect error])”

Cause: The memory card inserted in the card slot is write-protected.

Solution: Release the write protection of the memory card.

Cause: The setting [Memory Card Protect] is set to [ON] .

Solution: Set [Memory Card Protect] to [OFF] , and connect the USB cable again.

“?” Cannot read from memory card.

Cause: The question mark [?] indicates that the data may be a J PEG file containing an image with the resolution size: 6400 dpi x 6400 dpi or greater. If the data is not in the J PEG format, it is not included in the number of images.

Solution: Print from the computer.

“Error during scanning memory card. Pull the card and turn the machine off and on.”

Cause: Data in the memory card cannot be accessed.

Solution: Check the data in the memory card from a digital camera.

Check the connection between the multi-card board and the SPCNT board.

Replace the Multi Cards Board.

Replace the SPCNT board.

“There is no images in memory card”

Cause: The image data in the memory card are not in the file formats that are valid in this machine.

Solution: Print from the computer.

2-2 New Error Codes and Recovery Methods

Those error codes that have been added starting with the product and those error codes for which remedies unique to the product are offered are shown together with causes and remedies, where applicable.

341 Maintenance jet waste ink capacity full

Solution: Replace the waste ink absorber as follows in the error occurs:

- (1) Select [7] PRINTER TEST in the service mode and select [5] INK ABS CAPA under the [7] , then input “ 0” .
- (2) Check to make sure that no image exist in memory; then, turn off the power, remove the appropriate parts, and replace the waste ink absorber.

342 Cleaning absorption waste ink capacity full

Solution: Replace the waste ink absorber as follows in the error occurs:

- (1) Select [7] PRINTER TEST in the service mode and select [5] INK ABS CAPA under the [7] , then input “ 0” .
- (2) Check to make sure that no image exist in memory; then, turn off the power, remove the appropriate parts, and replace the waste ink absorber.

343 Ink detection waste ink capacity full

Solution: Replace the waste ink absorber as follows in the error occurs:

- (1) Select [7] PRINTER TEST in the service mode and select [5] INK ABS CAPA under the [7] , then input “ 0” .
- (2) Check to make sure that no image exist in memory; then, turn off the power, remove the appropriate parts, and replace the waste ink absorber.

352 Printer control EEPROM head information error

Cause: The EEPROM for printer control is faulty.

Solution:

- (1) Turn off and then on the power.
- (2) Turn off the power, and replace the printhead.
- (3) Replace the SPCNT board.

NOTE:

In the presence of # # 352, the carriage unit will not move to printhead replacement position even when the inner cover is opened. Moreover the carriage will not be locked in position even when the power is turned off. When replacing the printhead, be sure to turn off the power, and draw out the carriage before replacement.

355 Lit-up motor for CD-R print malfunctioned

Cause: In performing a CD-R print, the motor to lift up the carriage shaft is malfunctioned.

Solution:(1) Turn off and then on the power.

(2) Check the connection from the SHEET FEED unit to the SPCNT board ass'y (J PM1).

(3) Replace the SHEET FEED ASS'Y.

(4) Replace the SPCNT board.

356 ASF cam sensor error

Cause: An error occurs at the ASF cam sensor in the ASF (Auto Sheet Feeder) unit.

Solution: (1) To reboot, press [OK] button or turn off and then on the power.

(2) Replace the SHEET FEED ASS'Y.

357 ASF paper feed (AP) position error

Cause: An error occurs at the AP positioning in the ASF (Auto Sheet Feeder) unit.

Solution: (1) To reboot, press [OK] button or turn off and then on the power.

(2) Replace the SHEET FEED ASS'Y.

(3) Replace the SPCNT board.

358 USB Host VBUS overcurrent error

Cause: Overcurrent is applied to the VBUS signal of USB.

Solution: (1) To reboot, press [OK] button or turn off and then on the power.

(2) Replace the SPCNT board.

359 Paper feed position error

Cause: An error occurs at the paper feed positioning.

Solution: (1) To reboot, press [OK] button or turn off and then on the power.

(2) Replace the SHEET FEED ASS'Y.

(3) Replace the SPCNT board.

360 Paper feed cam sensor error

Cause: An error occurs at the paper feed cam sensor.

Solution: (1) To reboot, press [OK] button or turn off and then on the power.

(2) Replace the SHEET FEED ASS'Y

(3) Replace the SPCNT board.

361 Valve sensor error

Cause: An error occurs at the valve sensor in the Purge unit.

Solution: (1) To reboot, press [OK] button or turn off and then on the power.

(2) Replace the SPCNT board.

362 Motor driver malfunctioned error

Cause: The motor driver is malfunctioned due to heating, etc.

Solution: (1) To reboot, press [OK] button or turn off and then on the power.

(2) Replace the SPCNT board.

2-3 Warnings

Main body (no LCD indications)

| Displayed warning | Remarks |
|-------------------|---------|
| None | None |

2-4 Troubleshooting by symptom

| | Symptom | Solution | Remarks |
|----------------|--|--|---------|
| General errors | The unit does not power on. | (1) Check the power cord connection. (2) Check the connection between the SPCNT board (J PSU1) and power supply unit. (3) Replace the power supply unit. | |
| | Nothing is displayed. | (1) Check the connection between the Operation panel unit and SPCNT board (J PANEL1). (2) Replace the SCANNER unit. (3) Replace the SPCNT board. | |
| | Part of the Viewer does not display anything. | (1) If the test mode can be used, check for faulty dot in Viewer (2) Check the connection between the Operation panel unit and SPCNT board (J PNL1). (3) Replace the SCANNER UNIT. (4) Replace the SPCNT board ass'y. | |
| | The keys do not work. | (1) Check the connection between the SCANNER UNIT and SPCNT board (J PNL1). (2) Replace the SCANNER UNIT. (3) Replace the SPCNT board. | |

| | Symptom | Solution | Remarks |
|-------------------|--|--|---------|
| Printing problems | The paper is not feed properly. (The Paper feed motor does not run.) | 1) Check the connection from the sheet feed unit to the SPCNT board assy (J PM1). (2) Replace the sheet feed unit. (3) Replace the SPCNT board ass'y. | |
| | The paper is not picked up from the auto sheet feeder. | (1) Check the foreign matter in the paper feed section. (2) Check the connection SHEET FEED UNIT to the SPCNT board ass'y (J PM1). (3) Replace the SHEET FEED UNIT. (4) Replace SPCNT board ass'y. | |
| | The carriage motor does not run. | (1) Check the connection from the SHEET FEED unit to the SPCNT board ass'y (J PM1). (2) Replace the SHEET FEED unit. (3) Replace the SPCNT board ass'y. | |
| | Carriage error (The carriage comes into contact with the push-on plates at the left and right sides, resulting in noise.) | (1) Check if grease adheres to the carriage encoder film. (2) Using lint-free paper impregnated with alcohol, wipe the carriage encoder film with care so as not to scratch the film. (3) If a lot of grease adheres to the carriage, replace the carriage board because grease might be spread to the sensor on the carriage board. (4) Replace the carriage encoder film. | |

| | Symptom | Solution | Remarks |
|------------------------|--|---|---------|
| Printing Quality Error | <ul style="list-style-type: none"> • The printer does not at all. • Printing stops midway. • Certain colors are not printed. | <ol style="list-style-type: none"> (1) Remove the printhead and re-install it. (2) Carry out nozzle cleaning on the printhead five times with the cleaning operation, than visually check the test print for non-discharge of ink from nozzle (Fig. 1-2) (3) Remove and reinstall the printhead. (4) Replace the appropriate ink tank. (5) Replace the printhead. (6) Replace the SPCNT board ass'y. (7) Replace the purge unit. | |
| | <p>Blotches appear Blank ink appear</p> | <ol style="list-style-type: none"> (1) Remove and reinstall the printhead. (2) Carry out nozzle cleaning on the printhead five times with the cleaning operation, than visually check the test print for non-discharge of ink from nozzle (Fig. 1-2) (3) Perform print head refreshing, and print out Nozzle check pattern. Visually check the test print for non-discharge of ink from nozzle (Fig. 1-2) (4) Replace the appropriate ink tank. (5) Replace the printhead. (6) Check the connection of the carriage ribbon cable and the SPCNT board. (J HD1, J HD2) (7) Replace the carriage unit. (8) Replace the SPCNT board. (9) Replace the purge unit. | |

| | Symptom | Solution | Remarks |
|--------------------------------|---|--|---------|
| The Scanning Image Is Abnormal | Nothing is printed. | (1) Check the connection between the contact sensor and SPCNT board (J CCD1). (2) Replace the SCANNER unit. (3) Replace the SPCNT board ass'y. | |
| | The image has vertical stripes. | (1) Clean the Document glass. (2) Check the connection between the contact sensor and SPCNT board (J CCD1). (3) Replace the SCANNER unit. (4) Replace the SPCNT board ass'y. | |
| | The halftone image contains black dots. | (1) Clean the Document glass. (2) Check the connection between the SCANNER unit and SPCNT board (J CCD1). (3) Replace the SCANNER unit. (4) Replace the SPCNT board ass'y. | |
| Faulty CD-R (230V only) | The CD-R Tray is not recognized. | (1) Remove the CD-R Tray, and place the CD-R Tray again. (2) Check the connection between the CARRIAGE UNIT and SPCNT board ASS'Y (J HD1, J HD2). (3) Replace the CARRIAGE UNIT. (4) Replace the SPCNT BOARD ASS'Y. | |
| Other | (As-received failure) The display appers in English. | Select the settings of [# 8CLEAR] -[ALL] and [# 5TYPE] (Type setting) in Service Mode, and turn the power OFF/ON with the power button (Software Power: OFF/ON). | |

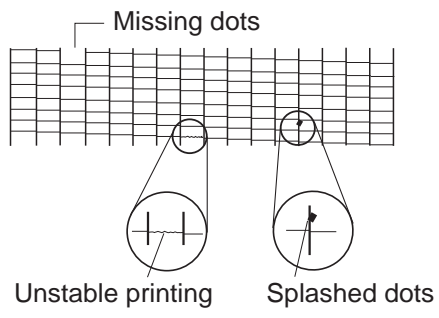

Figure1-2 Defective Pattern (Sample)

3. REPAIR

3-1 Notes on Service Part Replacement (and Disassembling / Reassembling)

| Service part | Notes on replacement* | Adjustment / settings | Operation check |
|---|--|---|--|
| SPCNT BOARD ASS'Y (HY7-3223) | - Before removal of the SPCNT board ass'y, remove the power cord, and allow for approx. 1 minute (for discharge of capacitor's accumulated charges), to prevent damages to the SPCNT board ass'y. - Before replacement, check the waste ink amount (by service test print or EEPROM information print). | After replacement: 1. Clear ALL * 2 (Initialize the EEPROM.) 2. TYPE setting * 2 Power SW OFF/ON 3. Reset the waste ink counter. 4. Service data setting 5. CD-R sensor calibration [See 3-6 Test mode 3-6-5 CD-R Calibration] [See 3-6. Service SW, for details of 1 to 4] 6. Perform the print head alignment in the user mode. | - EEPROM information print - Service test print - Copy - Printing via parallel or USB connection - Direct printing from a digital camera |
| INK ABSORBER (HY7-2885/2886/2887/ 2888/2889/2890/2891/ 2953) | | After replacement: 1. Reset the waste ink counter. [See 3.3. Adjustment / Settings, 3-3-8 Waste ink counter setting] | - EEPROM information print |
| CARRIAGE UNIT (HY7-2862) | Apply grease to the sliding portions. [See 3-3. Adjustment / Settings, 3-3-7 Grease application.] | 1. CD-R sensor calibration [See 3-6-5. CD-R Calibration] 2. Perform the print head alignment in the user mode. | - Service test print (Confirm CD-R and automatic print head alignment sensor correction.) |
| PAPER FEED MOTOR (HY7-2912) | - The red screws securing the paper feed motor are allowed to be loosened. (DO NOT loosen any other red screws.) | 1. Adjust the paper feed motor. [See 3-3. Adjustment / Settings, 3-3-1 Paper feed motor adjustment.] | |

| Service part | Notes on replacement* 1 | Adjustment / settings* 2 | Operation check |
|--------------------------------------|--|---|---------------------|
| LIFT CAM SHAFT (HY7-2902) | -Grease application to the sliding portions [See 3-3. Adjustment / Settings, 3-3-7 Grease application.] | After replacement: 1. LIFT CAM SHAFT phase adjustment See 3-3. Adjustment / Settings, 3-3-3 LIFT CAM SHAFT.] | -Service test print |
| TIMING SLIT STRIP FILM (HY7-2863) | -Upon contact with the film, wipe the film with ethanol. - Confirm no grease is on the film. (Wipe off any grease thoroughly with ethanol.) - Do not bend the film | After replacement: 1. Perform the print head alignment in the user mode. | -Service test print |
| TIMING SLIT DISK FILM (HY7-3083) | | | |
| PRINT HEAD (QY6-0049) | | After replacement: 1. Perform the print head alignment in the user mode. | -Service test print |
| PAPER EXIT TRAY ASS'Y (HY7-3220) | Align the left side of the tray with the T-part' angle of Solenoid Cam Gear to insert (after removing the tray, the angle returns to almost vertical by the force exerted by the spring). Then pull the tray open a little (approx. 30 – 60 degrees) and move it toward the left side to insert the other side of the shaft (see the photo in Figure 1-7). | | |
| LEFT COVER (HY7-3219) | Align the two claws of the bottom frame with the claws of the left cover (see the photo in Figure 1-8). | | |
| RIGHT COVER (HY7-3221) | Align the three claws of the bottom frame with the claws of the right cover (see the photo in Figure 1-9). | | |

* 1: General notes:

- Make sure that the flexible cables and wires in the harness are in the proper position and connected correctly.
[See 3-2. Special Notes on Repair Sericing, 3-3-1 Flexible cable and harness wiring, connection, for details.]
- Do not drop the ferrite core, which may cause damage.
- Protect electrical parts from damage due to static electricity.
- Before removing a unit, after removing the power cord, allow the printer to sit for approx. 1 minute (for capacitor discharging to protect the logic board ass'y from damages).
- Do not touch the timing slit strip film and timing slit disk film. No grease or abrasion is allowed.
- Protect the units from soiled with ink.
- Protect the housing from scratches.
- Exercise caution with the red screws, as follows:
 - i. The red screws of the paper feed motor may be loosened only at replacement of the paper feed motor unit (DO NOT loosen them in other cases).
 - ii. DO NOT loosen the red screws on both sides of the main chassis, securing the carriage shaft positioning (they are not adjustable in servicing).

- * 2: When SPCNT BOARD ASS'Y is replaced, be sure to select the settings of [# 8CLEAR] -[ALL] and [# 5TYPE] in Service Mode, and turn the power OFF/ON with the Power button (Software Power: OFF/ON). DO NOT turn the power OFF/ON by removing and inserting the power code (Hardware Power: OFF/ON). In this case, data may not be written correctly.



To attach the PAPER EXIT TRAY UNIT, align the tray with the T-part of the Solenoid Cam Gear to insert. Then pull the tray open a little and move it toward the left side to insert the other side of the shaft.

Figure1-3 Solenoid Cam Gear

The following photos show the left and the right cover claws. Align them for assembling.

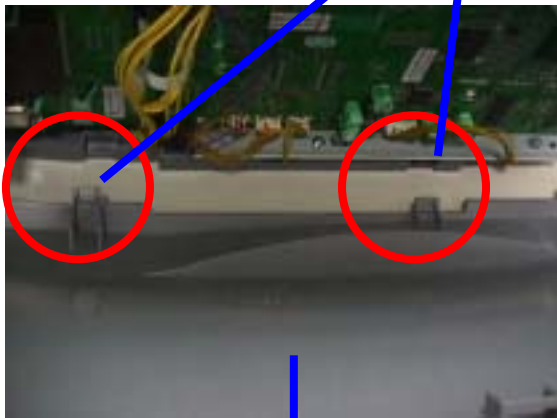

Figure1-4 LEFT COVER

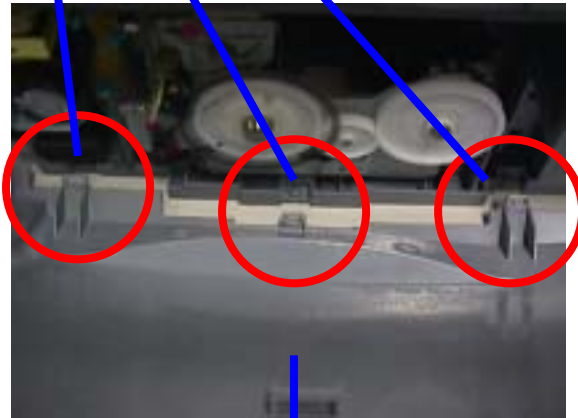

Figure1-5 RIGHT COVER

3-2 Special Notes on Repair Servicing

3-2-1 Flexible cable and harness wiring, connection

Be careful of wiring of the flexible cables and harness. Improper wiring or connection may cause breakage of a line, leading to ignition or emission of smoke.

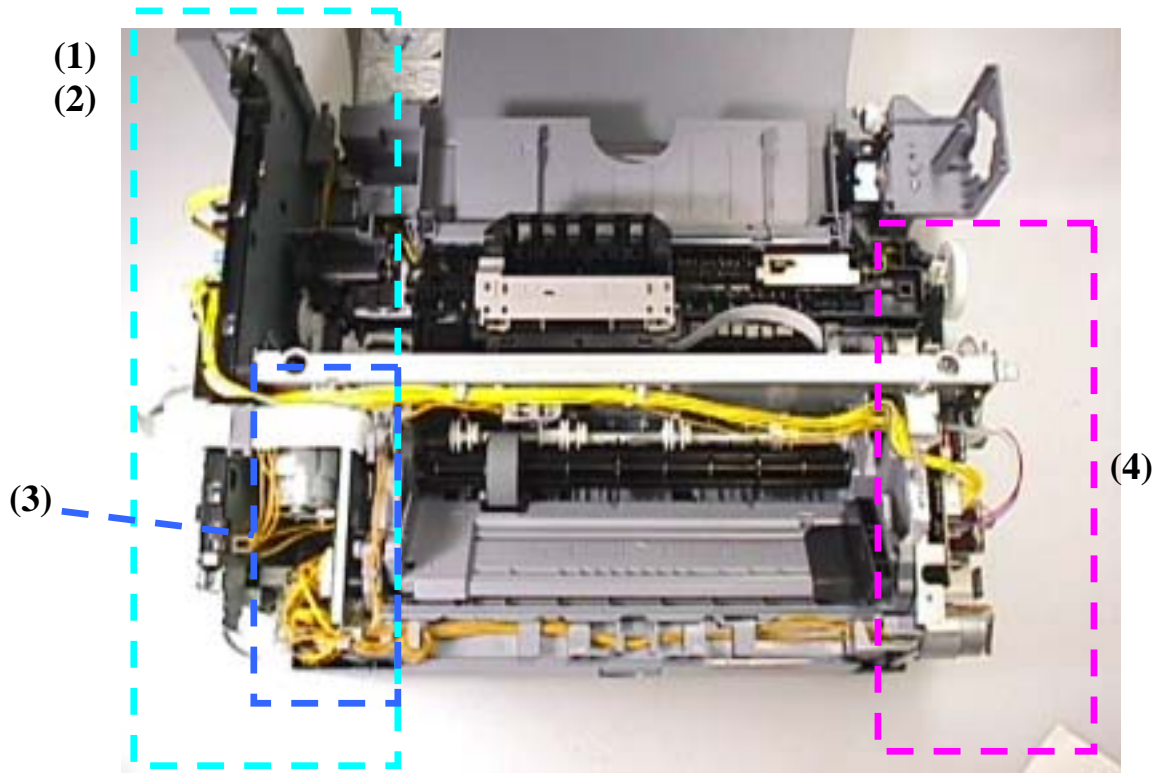

Figure 1-6 Flexible cable and harness wiring, connection

(1) IRDA board wiring

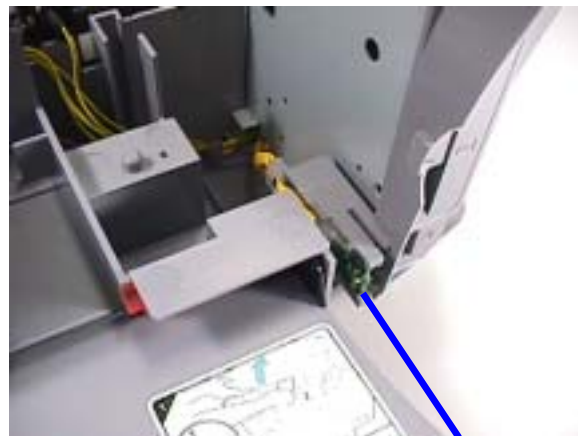

Figure 1-7 Cable Guide wiring

(2) SPCNT BOARD ASS'Y wiring

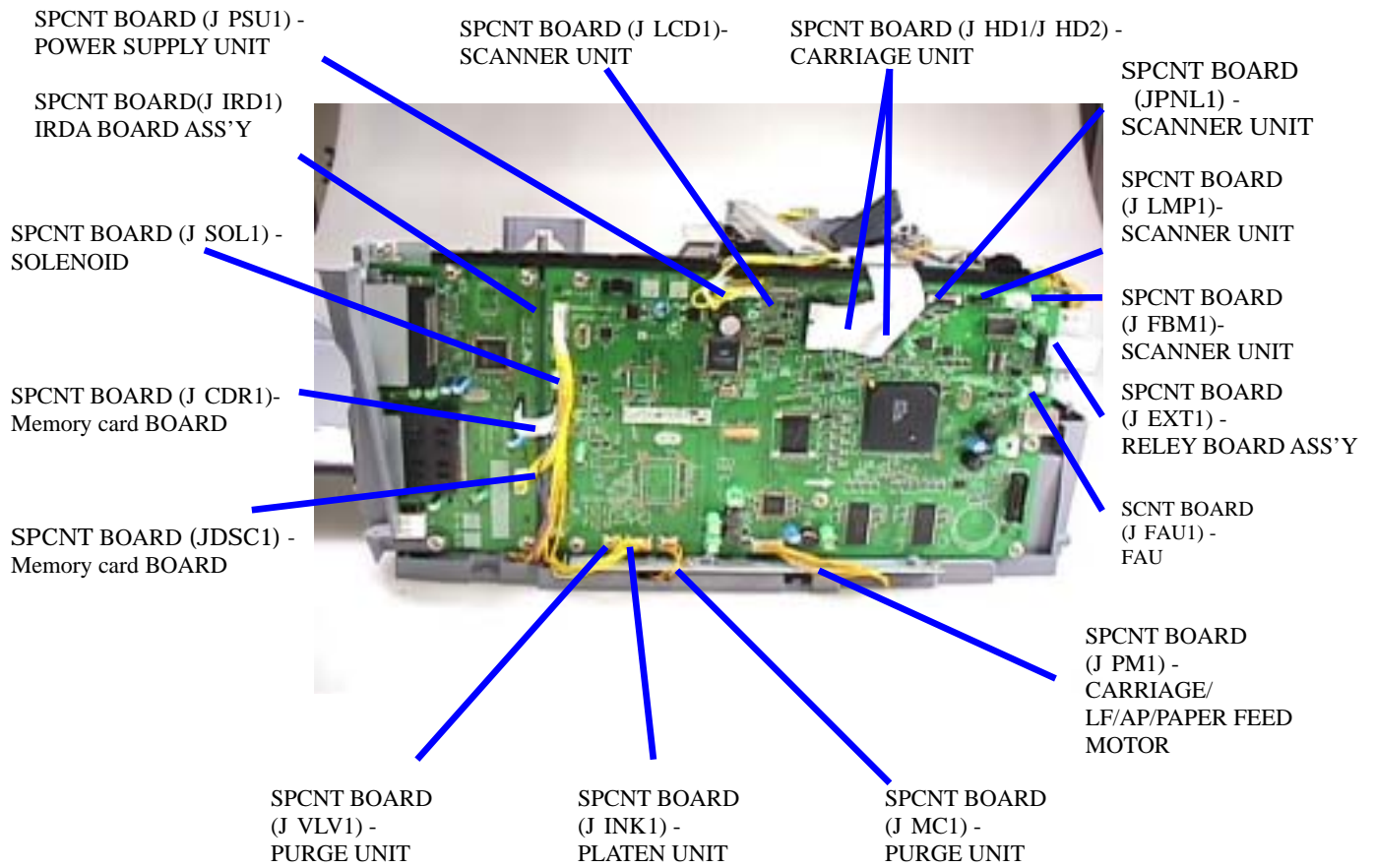

Figure 1-8 SPCNT BOARD ASS'Y wiring

(3) RELAY BOARD ASS'Y wiring

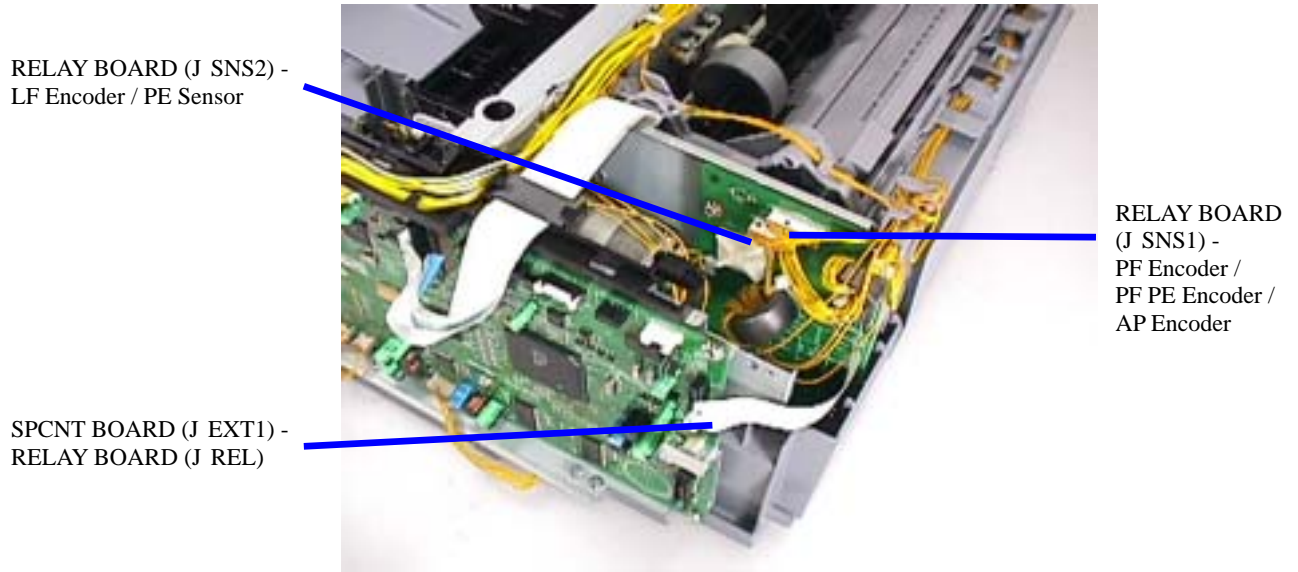

Figure1-9 RELAY BOARD ASS'Y wiring

(4) POWER SUPPLY UNIT wiring

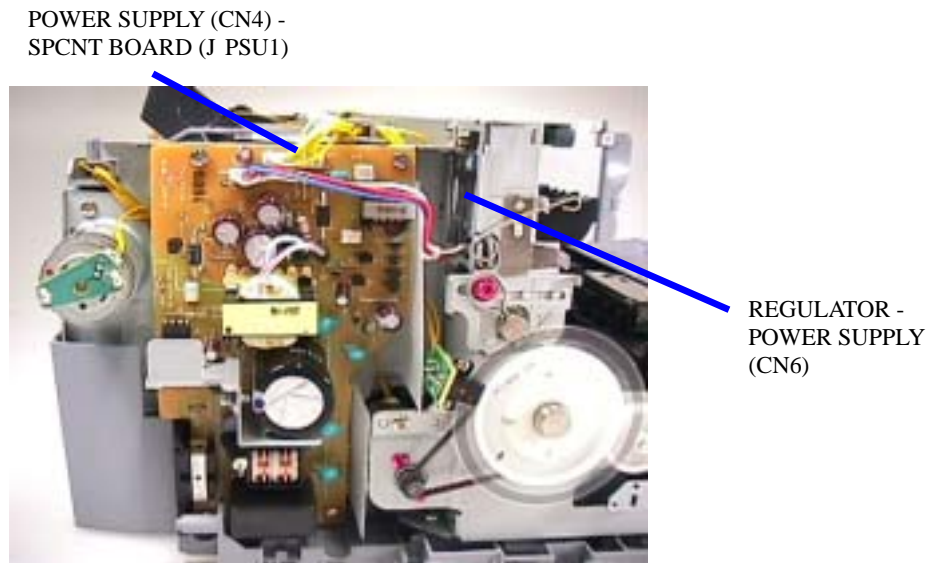

Figure1-10 POWER SUPPLY UNIT wiring

3-3 Adjustment / Settings

3-3-1 PAPER FEED MOTOR Adjustment

Perform the following adjustments when the paper feed motor unit is replaced:

- 1) When attaching the motor, fasten the screws so that the belt is properly stretched (in the direction indicated by the blue arrow in the figure below).
- 2) After replacement, be sure to perform the service test print, and confirm that no strange noise or faulty print operation (due to dislocation of the belt or gear, or out-of-phase motor, etc.) occurs.

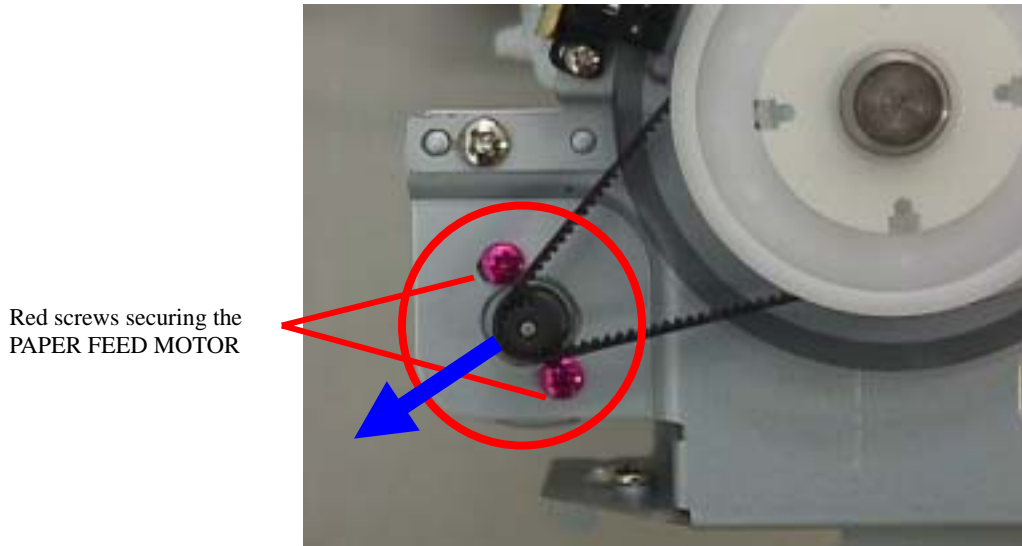

Figure 1-11 PAPER FEED MOTOR Adjustment

Note:

The red screws securing the paper feed motor may be loosened only at replacement of the paper feed motor unit. DO NOT loosen them in other cases.

3-3-2 CARRIAGE SHAFT gear adjustment

In installing a carriage shaft, the gear phase should be adjusted.

- (1) Insert the metallic pin shown below to the hole in the PURGE UNIT (see the photo (a) below) (until it reaches the end).

[Metallic pin]

- Diameter: 2.0 mm or less, and Length: 20.0 mm or more

(Use “ CARRIAGE SHAFT L SPRING: HY7-2867” , or unbent clip can be used in place of the pin.)

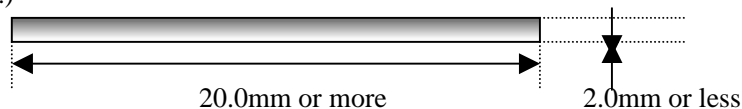

- (2) With the metallic pin inserted, turn the LIFT GEAR 2 clockwise (in the direction indicated by the arrow in the photo (b) below) until it reaches the end. (Stop when it cannot turn farther any more.) Under the conditions above, confirm that the ASF ARM LOCK LEVER is located upward (see Photo (c)) and the capping section is located at the capping position (see Photo (d)).

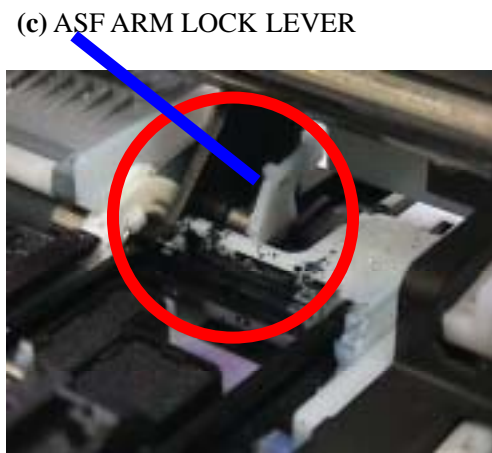
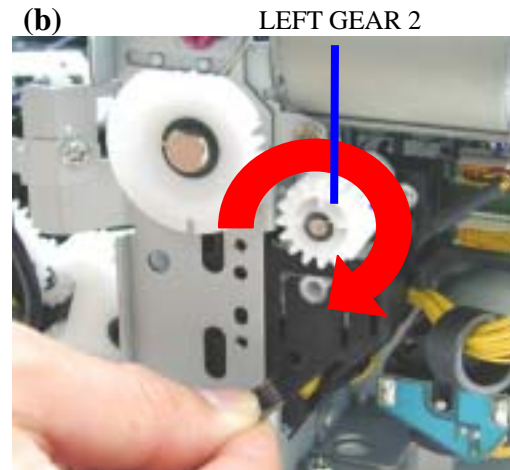
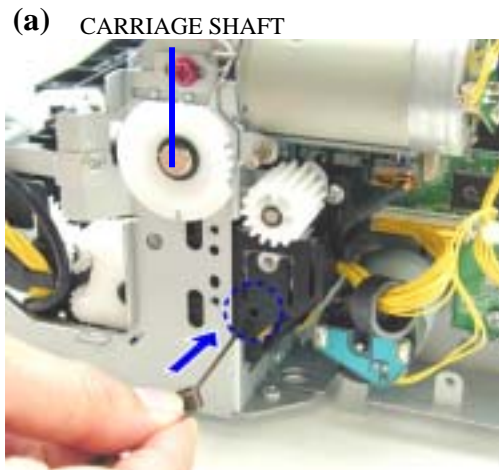

(3) Install the LEFT GEAR 1 by aligning it on the cutout of the CR SHAFT CAM R.

Align the two parts so that both surfaces shown at the top are horizontal.
Or, adjust so that the part of the CR SHAFT CAM R shown at the bottom is just at the bottom.

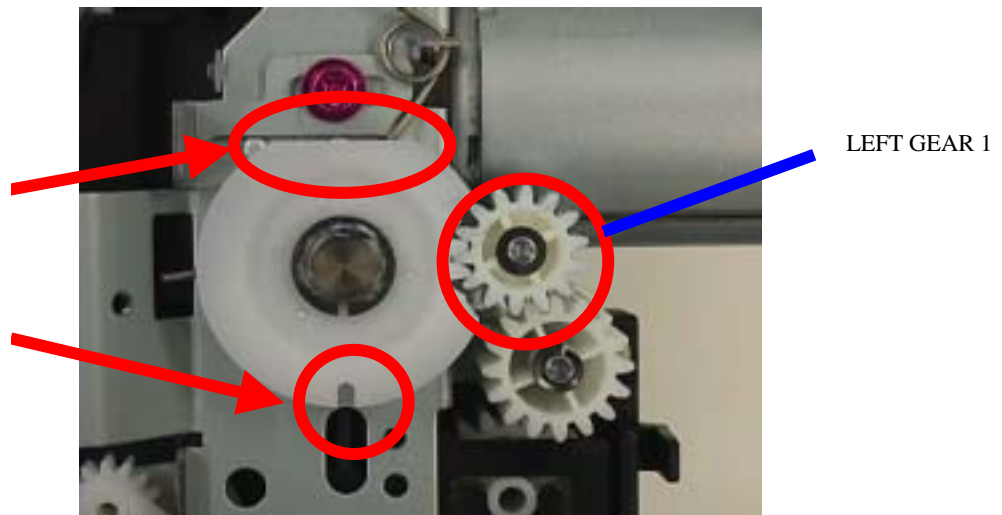

Figure 1-12 CARRIAGE SHAFT gear adjustment

3-3-3 Positioning in LIFT CAM SHAFT ASS'Y adjustment

- (1) Remove the PRESSURE ROLLER SPRING from the hook of the chassis, and apply it to the gash of the LIFT CAM SHAFT ASS'Y.

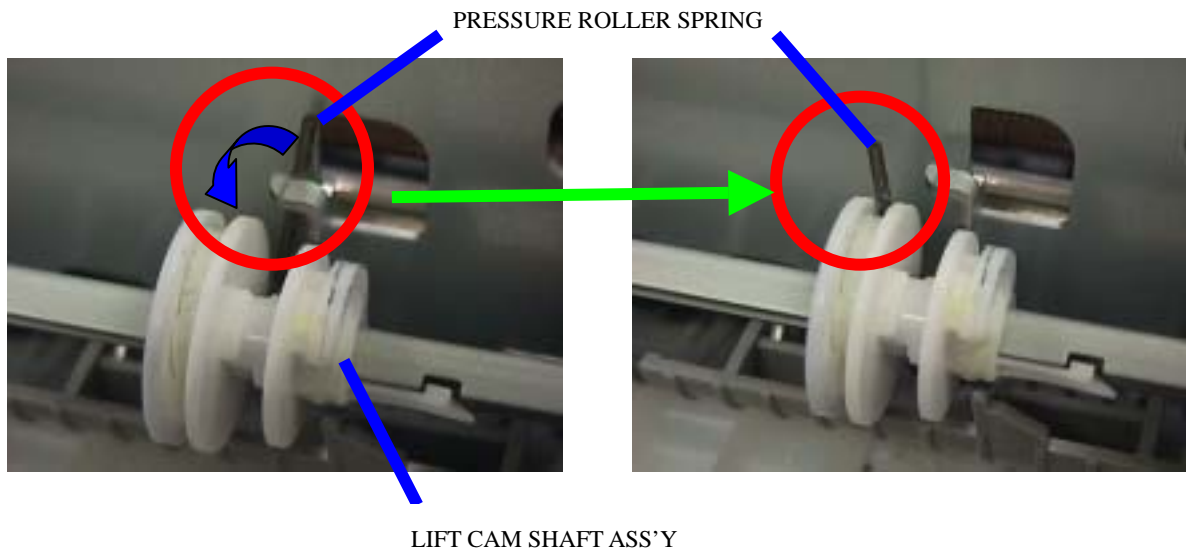

Figure 1-13 Positioning in LIFT CAM SHAFT ASS'Y adjustment 1

- (2) Turn the gear of the LIFT CAM SHAFT ASS'Y in the direction indicated by the arrow “a” in the photo (clockwise) until it reaches the end.
- (3) Turn the gear of the LIFT CAM SHAFT ASS'Y in the direction indicated by the arrow “b” in the photo below (counterclockwise) until it reaches the end.

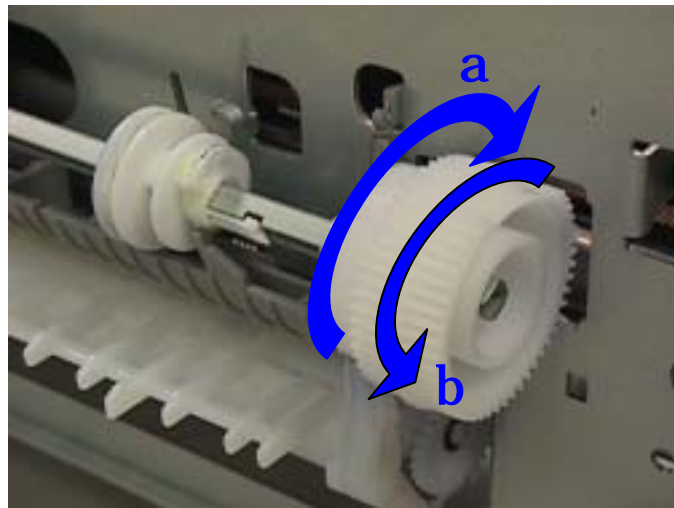

Figure1-14 Positioning in LIFT CAM SHAFT ASS'Y adjustment 2

3-3-4 SOLENOID CAM location

(1) Install the spring so that the Short end of the spring is at the top and the Long end of the spring is at the bottom. (The part has a protection against reverse installation.)

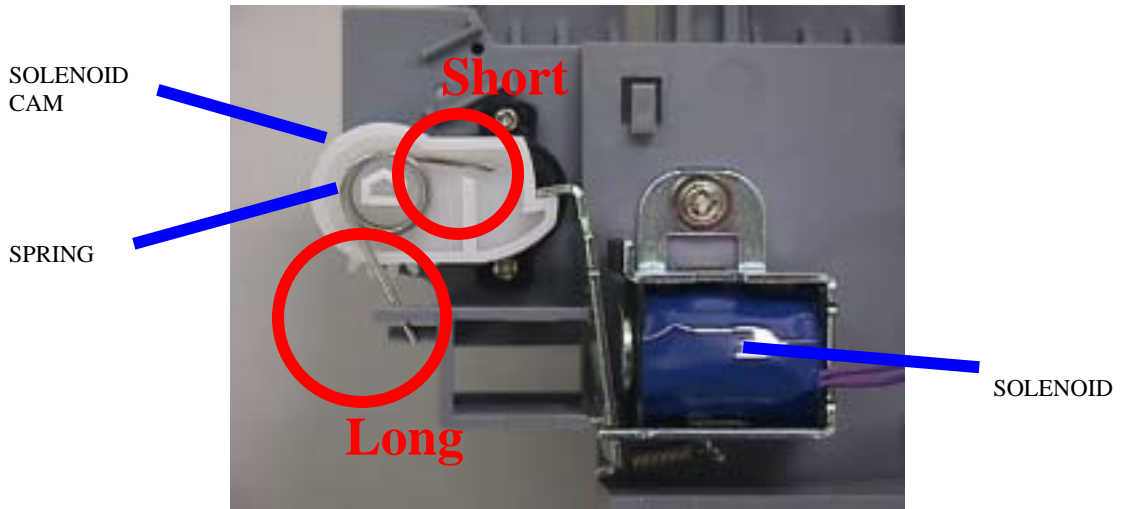

Figure 1-15 SOLENOID CAM spring location

3-3-5 CARRIAGE SHAFT CLIP location

(1) Adjust the ellipse area of CARRIAGE SHAFT CLIP and the edge of TIMING SLIT STRIP FILM

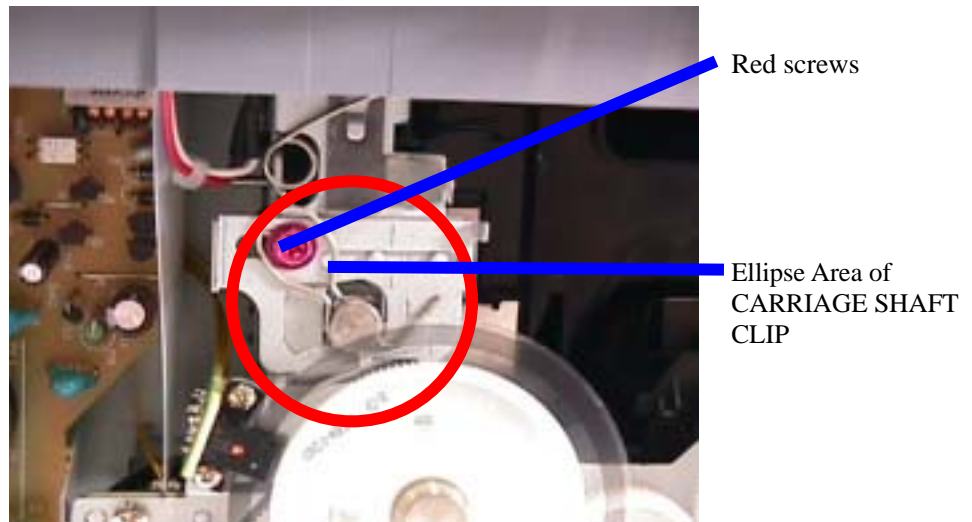

Figure 1-16 CARRIAGE SHAFT CLIP location

3-3-6 Applying White Sheet

- (1) Rib bumps are provided on the right side and the bottom side of the FAU (Film Adapter Unit) Protective Sheet. (See the photo shown below, the directions when you open the document cover.) Temporarily attach the white sheet to a place inside the rib bumps on the right side (about 1 mm inside or less).
- (2) Attach the whole part of the white sheet, by aligning the edge of the white sheet on the line of rib bumps on the bottom side of the FAU Protective Sheet. (See the photo shown below, one line inner from the outmost line.)

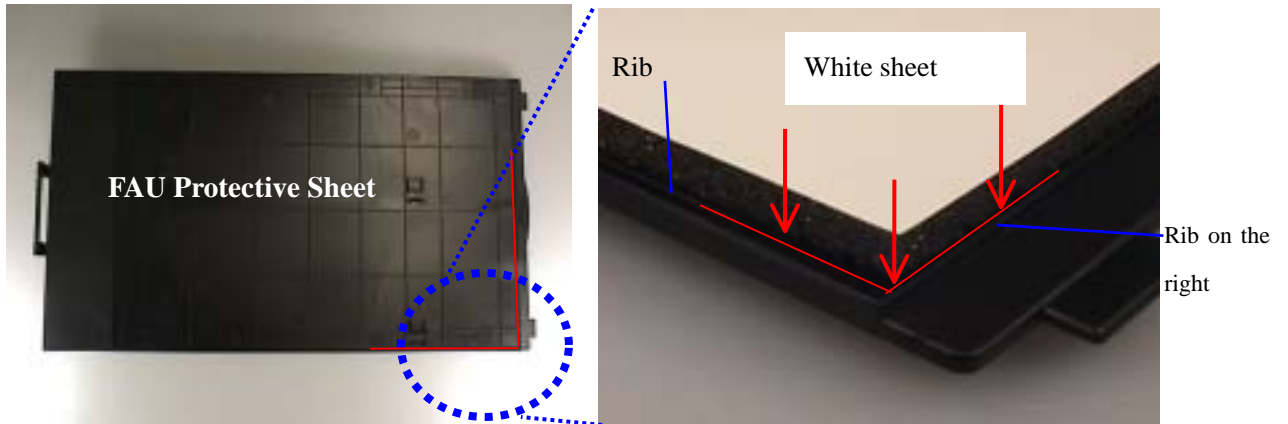

Figure1-17 Applying white Sheet

- (3) Confirm the location to apply the white sheet. For the confirmation, lift up the document cover just a little, and look into to visually confirm that the edges of the white sheet are not placed on the scanner top cover (molded part).

OK Example: The edges of the white sheet are not located on the scanner top cover.

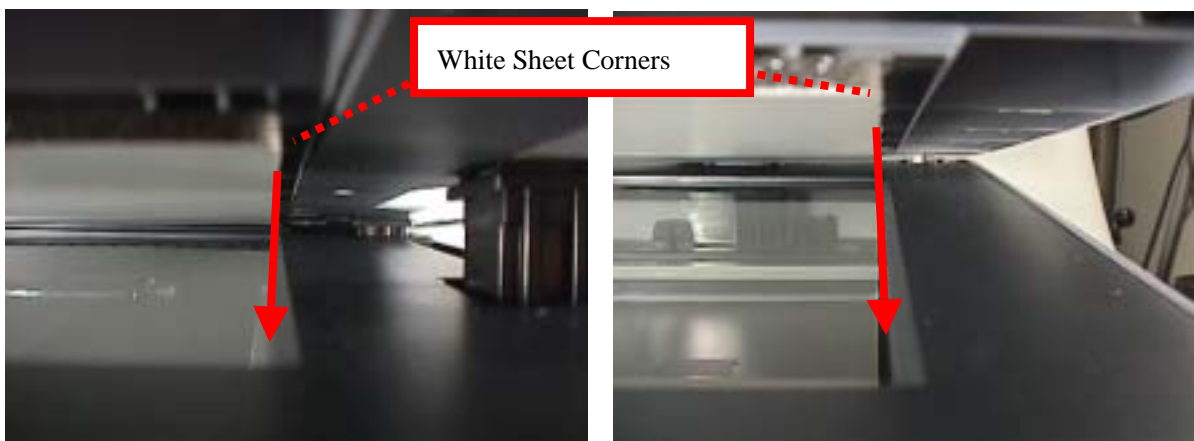

Figure1-18 Location confirmation to apply the white sheet (the rear side and the right side) (OK example)

NG Example: The edges of the white sheet are located on the scanner top cover.



**Figure1-19 Location confirmation to apply the white sheet (the rear side and the right side)
(NG example)**

3-3-7 Grease application

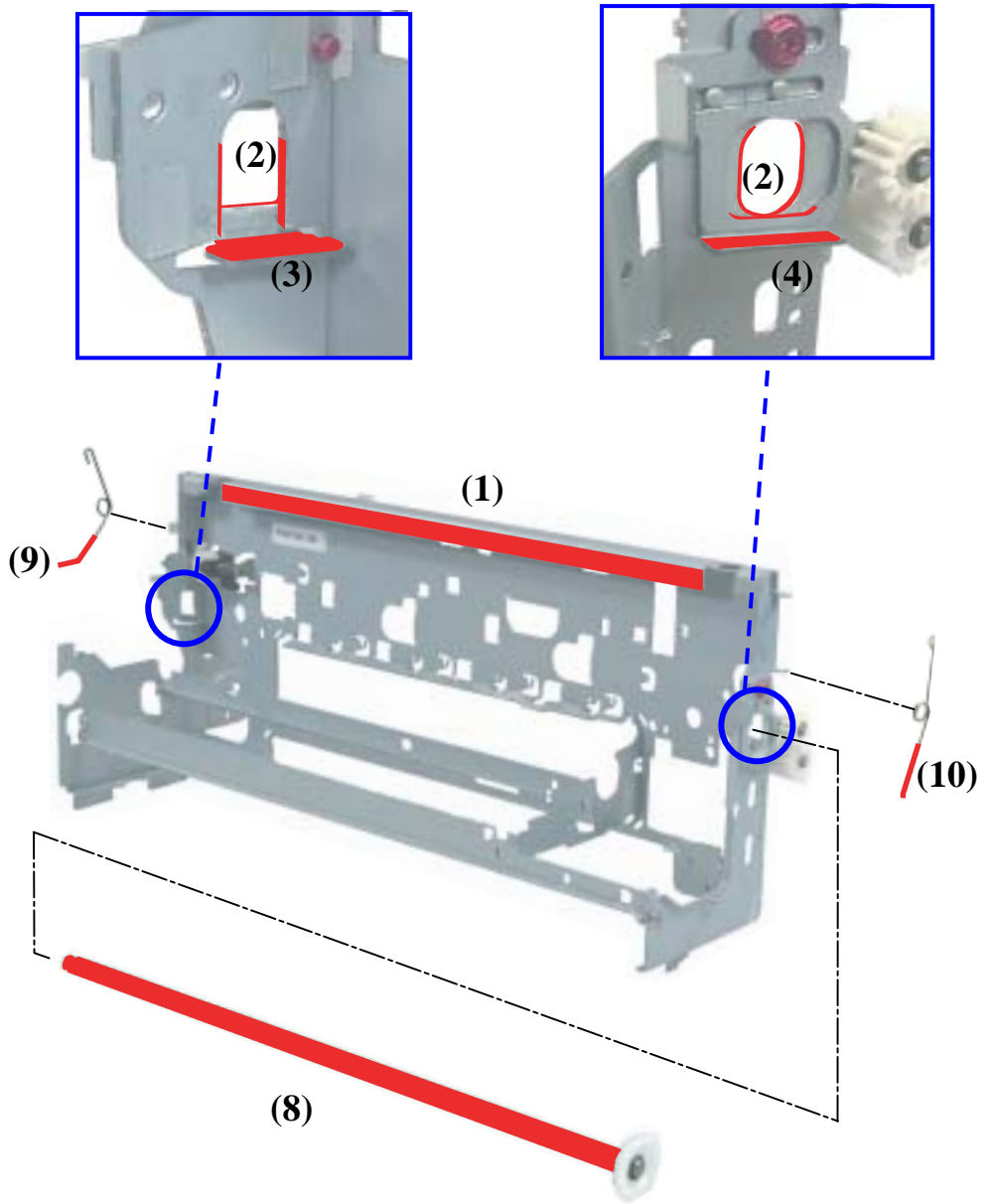

Figure 1-20 Grease application1

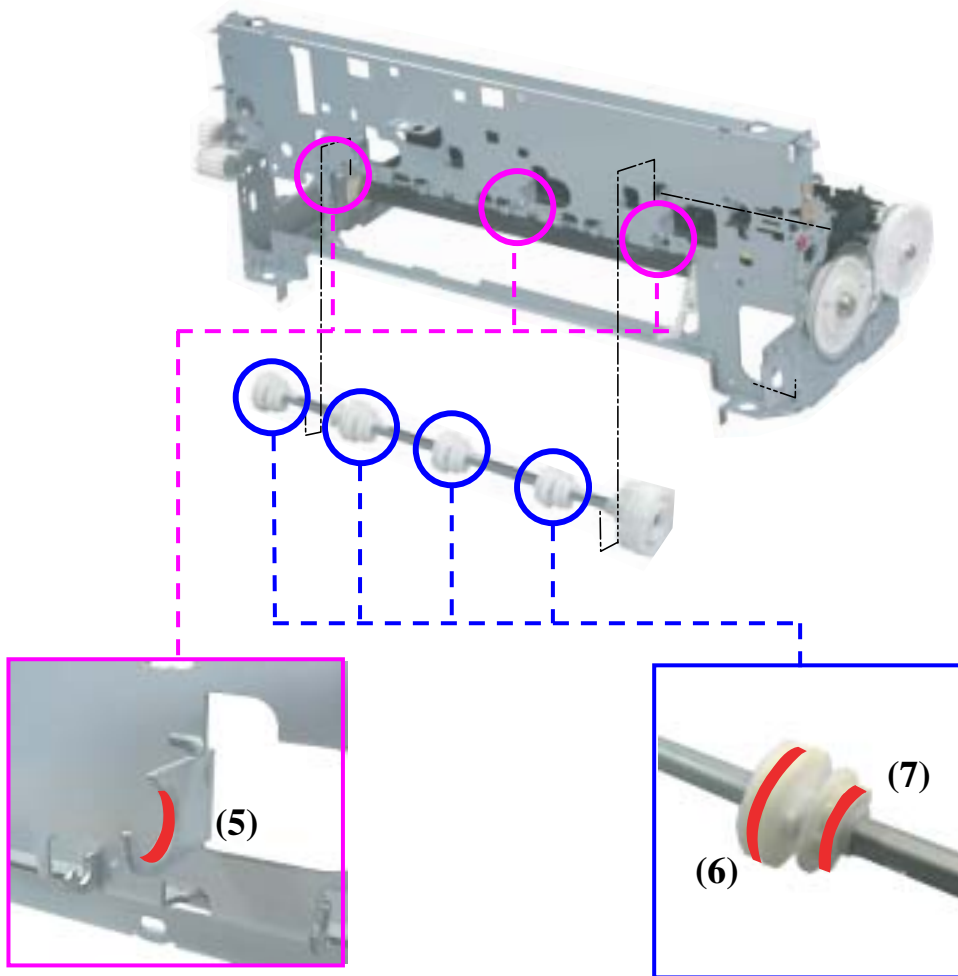

Figure 1-21 Grease application2

| Part name | Where to apply grease / oil | | Grease / oil name | Grease / oil amount |
|-------------------------|-----------------------------|---|-------------------|-------------------------|
| Chassis | 1 | Entire surface the CARRIAGE SLIDER contacts | FLOIL KG107A | Chassis |
| | 2 | CARRIAGE SHAFT sliding portion | FLOIL KG107A | |
| | 3 | CARRIAGE SHAFT CAM L sliding portion | MOLYKOTE HP300 | |
| | 4 | CARRIAGE SHAFT CAM R sliding portion | MOLYKOTE HP300 | |
| | 5 | LIFT CAM SHAFT sliding portion | FLOIL KG107A | |
| LIFT CAM SHAFT | 6 | SPRING sliding portion (4 points) | FLOIL KG107A | LIFT CAM SHAFT |
| | 7 | PRESSURE ROLLER ASS'Y sliding portion (4 points) | FLOIL KG107A | |
| CARRIAGE SHAFT | 8 | CARRAGE and CARRIAGE SHAFT sliding portion | FLOIL KG107A | CARRIAGE SHAFT |
| CARRIAGE SHAFT SPRING L | 9 | CARRIAGE SHAFT sliding portion (over the area more than 2/3 from the top end of the spring) | FLOIL KG107A | CARRIAGE SHAFT SPRING L |
| CARRIAGE SHAFT SPRING R | 10 | CARRIAGE SHAFT sliding portion (over the area more than 2/3 from the top end of the spring) | FLOIL KG107A | CARRIAGE SHAFT SPRING R |

Note: 1 drop = 9 to 18 mg

3-3-8 Waste ink counter setting

When the SPCNT board ass'y is replaced, check the amount of the waste ink capacity before the replacement. After the replacement, register the amount of the waste ink capacity on the new SPCNT board ass'y that has been replaced.

To check the waste ink capacity, print out the EEPROM information print.

To register the waste ink capacity, select [7] ENTER - [5] INK ABS CAPA in the service mode, and input a value between 0 - 100 (%) with the numeric keys.

3-4 User data flow

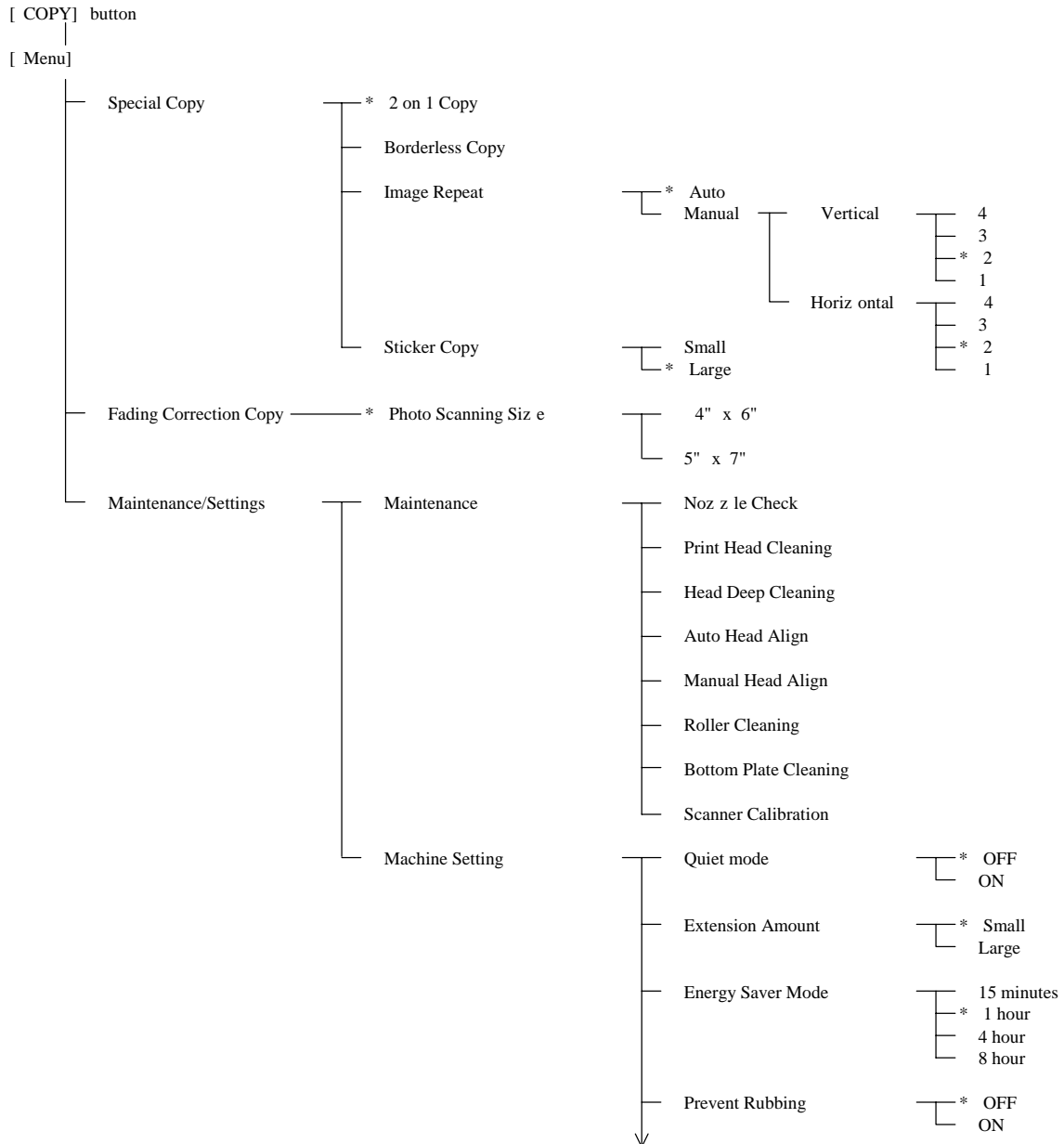

Figure 1-22 Use data flow (1/3)

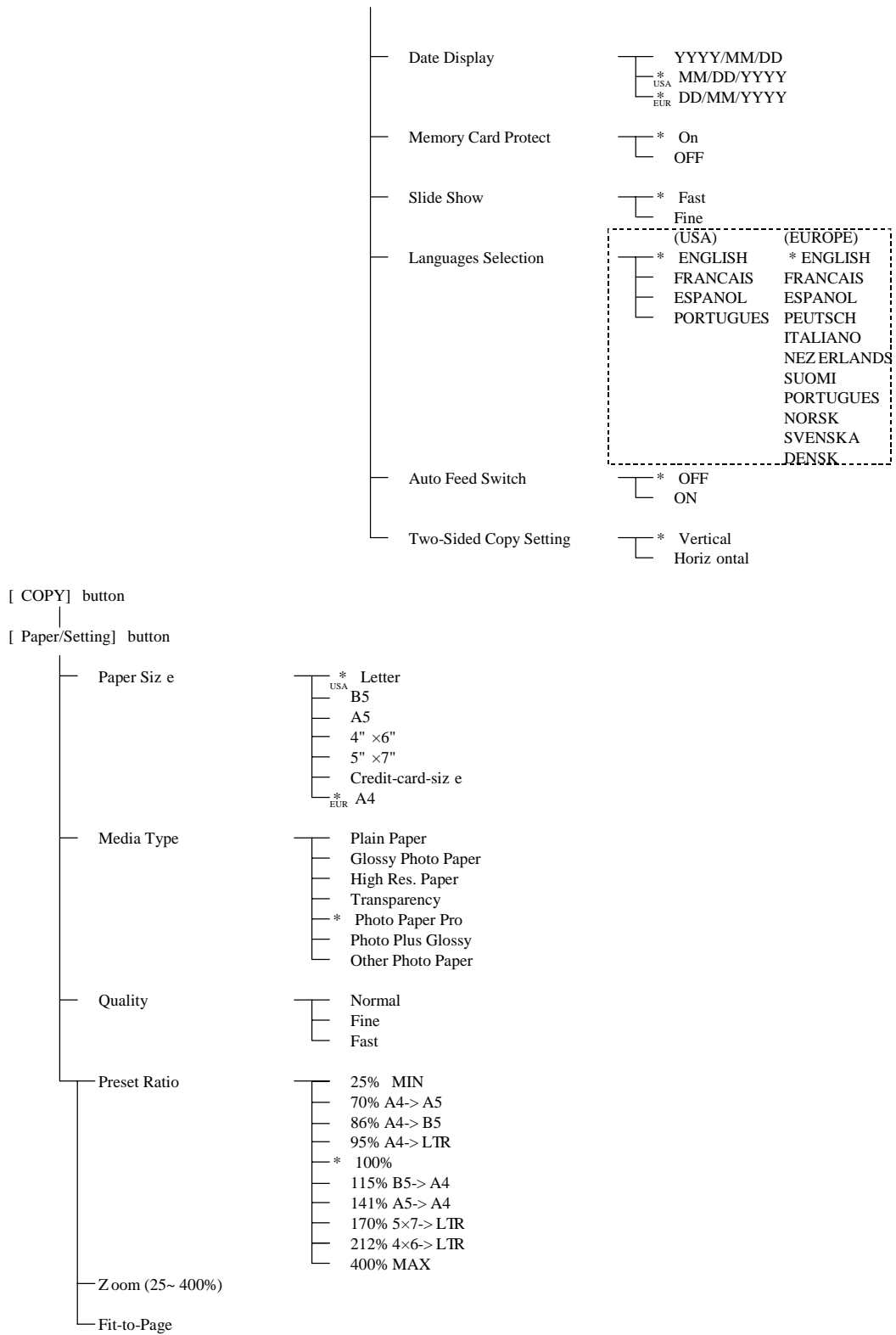

Figure 1-23 Use data flow (2/3)

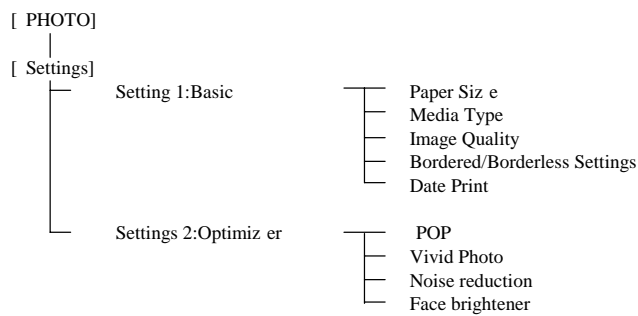
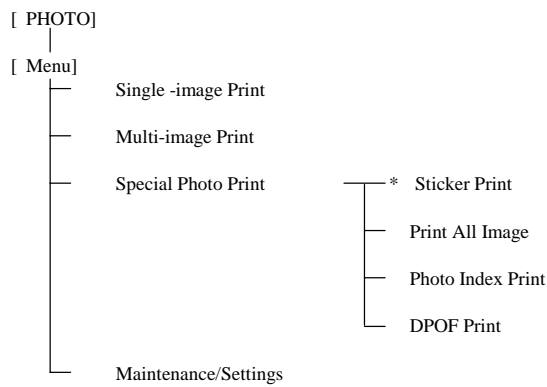
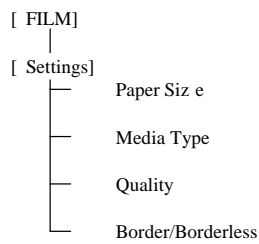
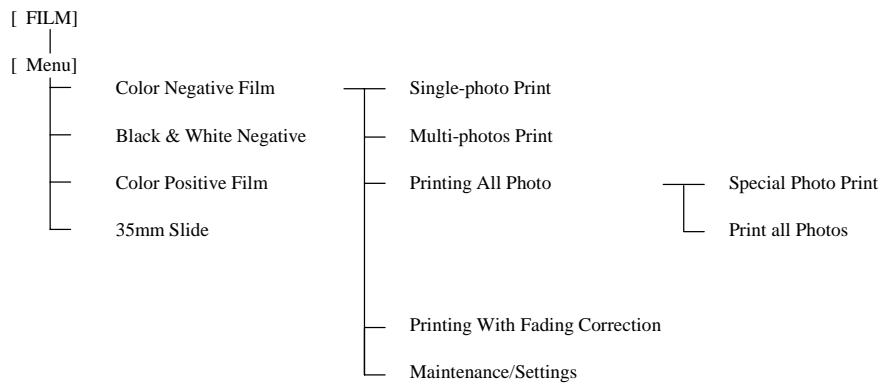

Figure 1-24 Use data flow (3/3)

3-5. SERVICE SWITCHES

3-5-1 Hardware Switches

There is no service hardware switch on the Circuit board.

3-5-2 Service Data Setting

Service data can be checked and changed with items on display menus. The effective SSSWs/ parameters and their default values in this machine are shown in *Service menu* in this chapter.

#1 SSSW (Service soft switch settings)

These setting items are for basic fax service functions such as error management, echo countermeasures, and communication trouble countermeasures.

#2 MENU (MENU switch settings)

These setting items are for functions required during installation, such as NL equalizer and transmission levels.

#3 NUMERIC Param. (NUMERIC parameter settings)

These setting items are for inputting numeric parameters such as the various conditions for the FAX/TEL switching function.

#4 NCU (NCU settings)

These setting items are for telephone network control functions such as the selection signal transmission conditions and the detection conditions, for the control signals sent from the exchange.

#5 TYPE (TYPE setting)

The type setting makes the service data conform to a specific country communications standards. There is only one setting item in this block.

#6 GENESIS (UHQ function setting)

These setting items are for scanned image processing such as edge enhancement and error diffusion processing.

#7 PRINTER (PRINTER function settings)

These setting items are for basic printer service functions such as the reception picture reduction conditions. Also there is an item for resetting the printer section without switching the power off-on.

#8 CLEAR (Data initialization mode)

Various data are initialized by selecting one of these setting items. There is a setting item for checking/inputting the total number of pages printed and total number of pages scanned by this fax.

#9 ROM (ROM management)

ROM data such as the version number and checksum are displayed.

3-5-3 Service Data Registration / Setting Method

Service data can be registered/set by the following operations:

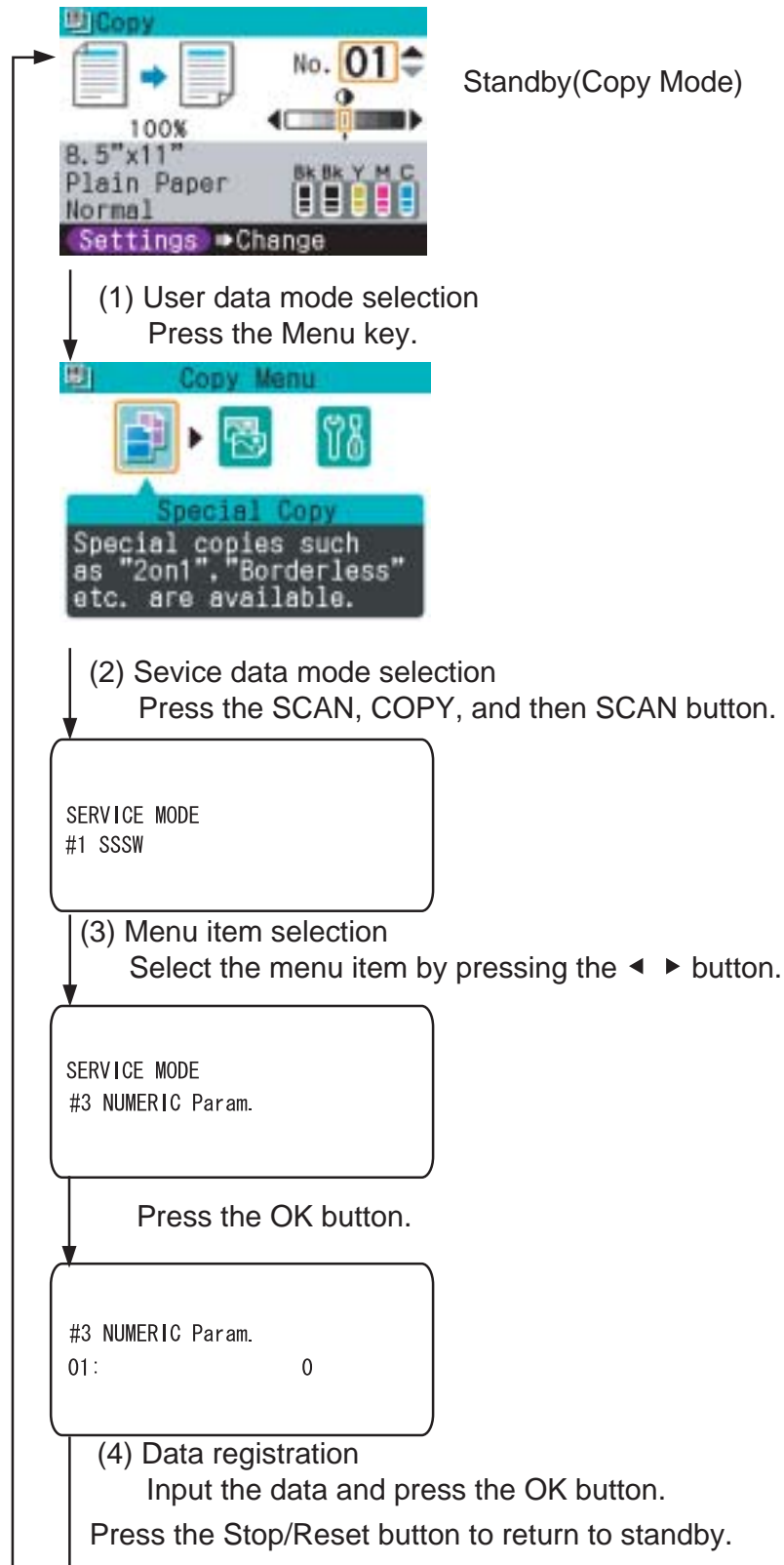

Figure 1-25 Service Data Setting Method

3-5-4 Service Data Flowchart

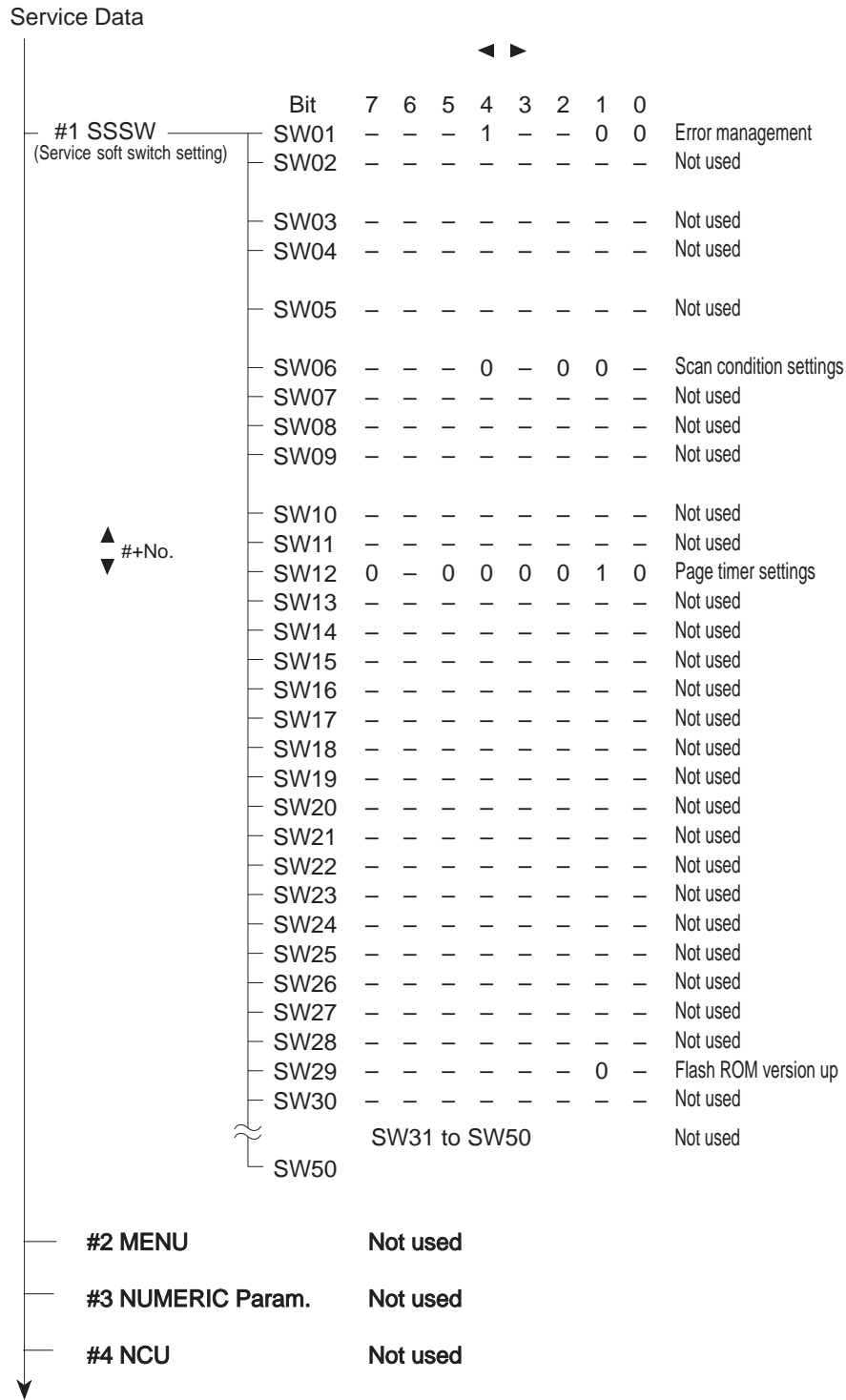

Figure 1-26 Service Data (1/4)

Caution:

The switches marked “-” are not used. Do not change their settings.

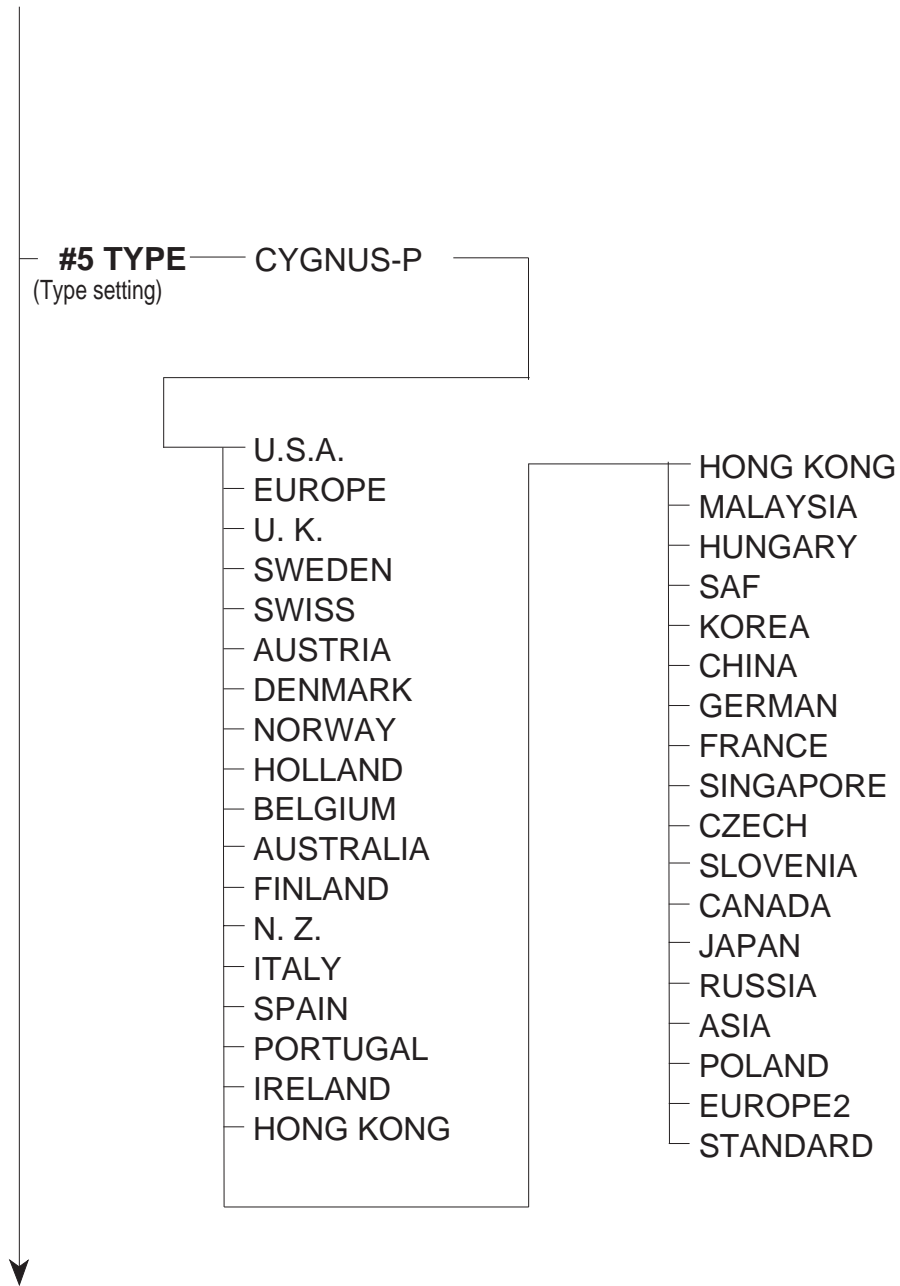

Figure 1-27 Service Data (2/4)

Caution:

#5 TYPE (TYPE Setting)

For the machine type settings, select according to the products as follows:

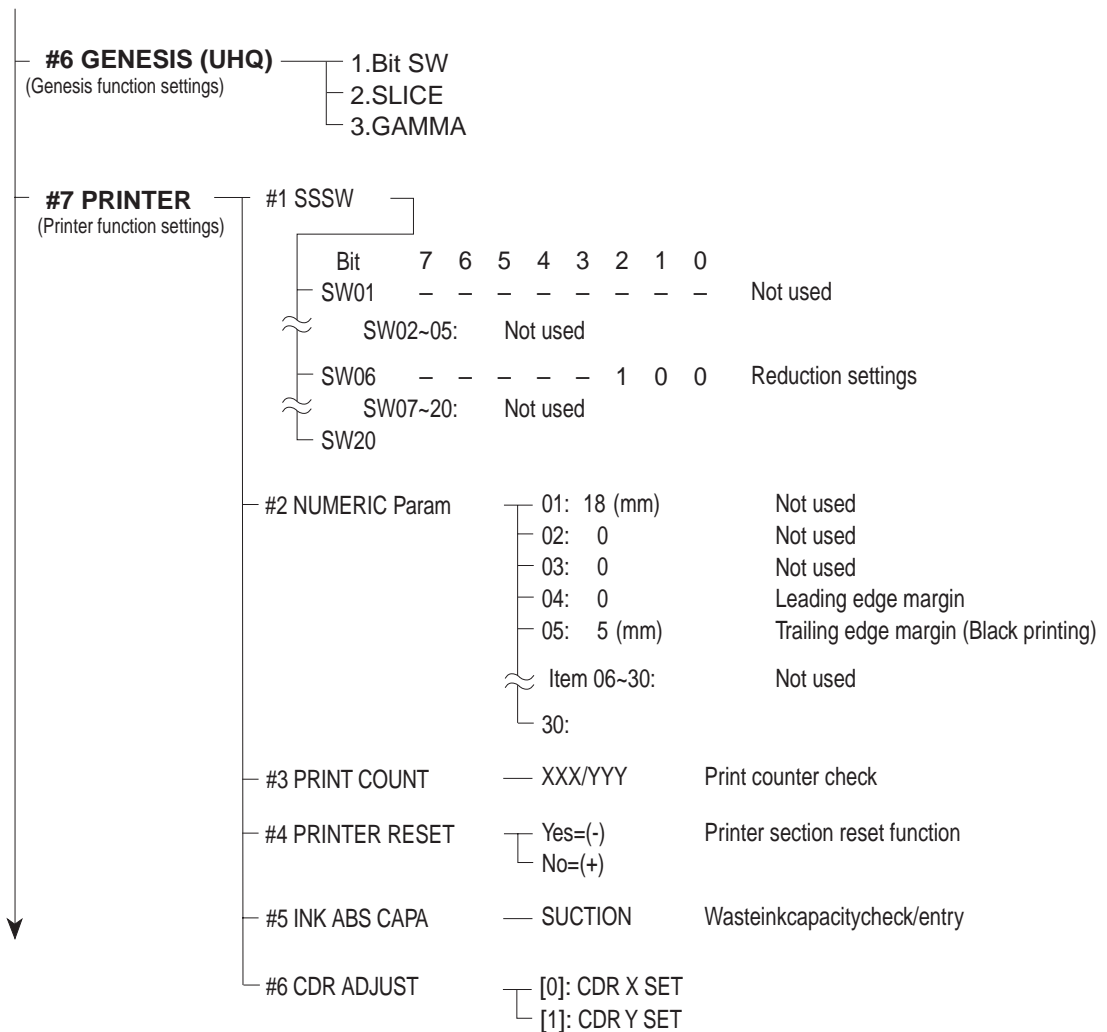

Figure 1-28 Service Data (3/4)

Caution: #6 GENESIS (UHQ function settings)

Tampering with this setting may cause the scanned image quality to deteriorate.

Do not change these settings.

Memo:

7 PRINTER (Printer function settings)

1. At # 5 INK ABS CAPA, you can check or register the capacity of waste ink ejected during the cleaning operation. For the waste ink capacity registration, register a value between 0 – 100 (%) with the numeric keys.

The absorption amount of the waste ink absorber is set based upon the amount that the BJ cartridge has ejected.

The settings of the waste ink capacity are stored in EEPROM of SPCNT BOARD.

When replacing the SPCNT BOARD, check the waste ink capacity before the replacement, and register the waste ink capacity at the new SPCNT BOARD after the replacement.

2. At # 6 CDR ADJ UST (CD-R Print writing position adjustment), you can adjust the writing position in X and Y directions within the following range.
+/-0.0mm, +/-0.1mm, +/-0.2mm, +/-0.4mm, +/-0.6mm, +/-0.8mm, +/-1.0mm

You can also perform this adjustment from “ CD-LabelPrint” or “ Easy-PhotoPrint” .

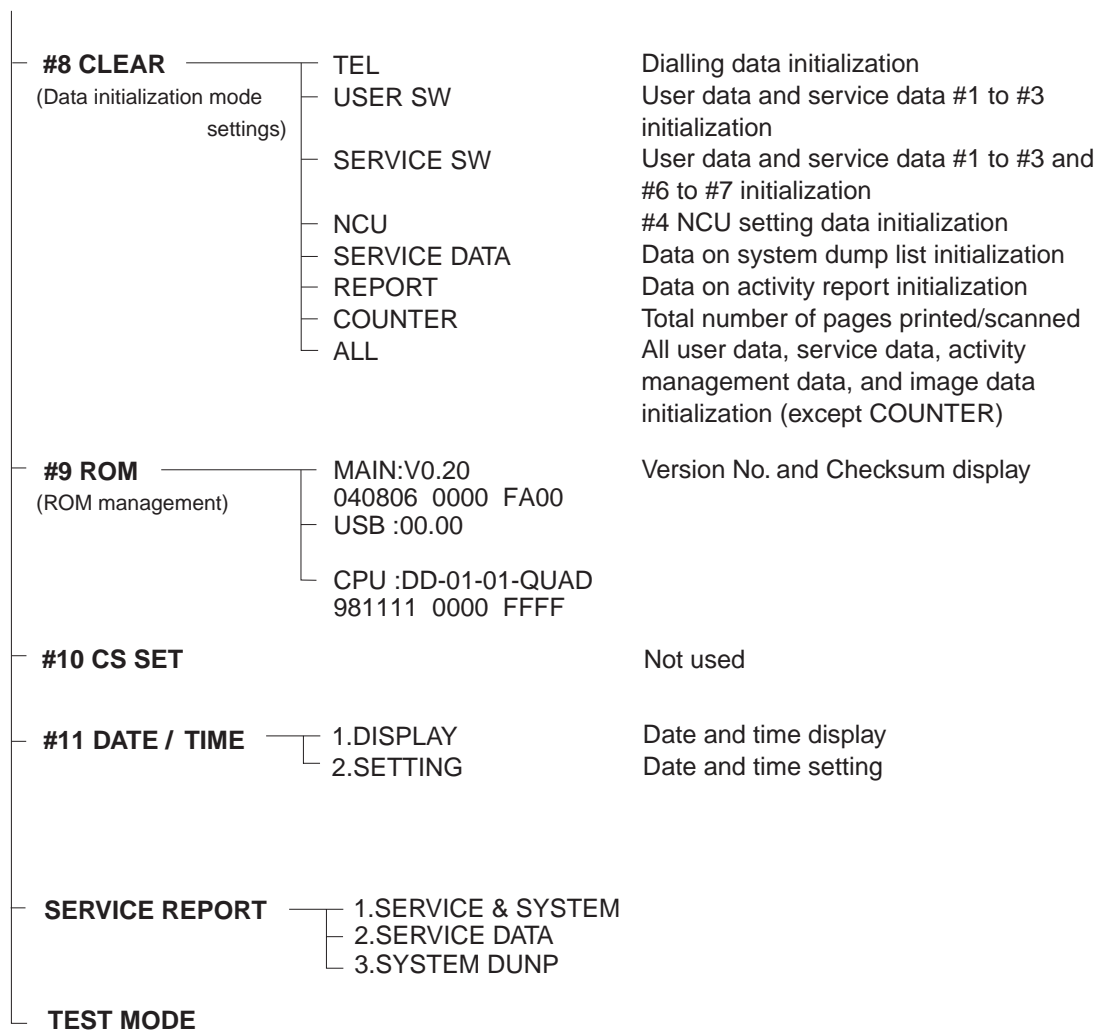

Figure 1-29 Service Data (4/4)

Caution:

If USER SW of # 8 CLEAR is selected, communication management data of user data is not deleted.
However, if TEL or SERVICE SW is selected, the communication management data of user data is deleted.

If ALL of # 8 CLEAR is performed, be sure to set # 5 TYPE and turn the power OFF/ON with the Power button (Software Power: OFF/ON). DO NOT turn the power OFF/ON by removing and inserting the power code (Hardware Power: OFF/ON). In this case, data may not be written correctly.

Memo:

The date/time settings at # 11 DATE/TIME is equivalent to the settings at [FAX SETTINGS] – [USER SETTINGS] – [DATE&TIME] . Neither has priority.

3-5-5 Explanation of service data

a) SSSW (Service Soft Switch settings)

The items registered and set by each of these switches comprise 8-bit switches. The figure below shows which numbers are assigned to which bits. Each bit has a value of either 0 or 1.

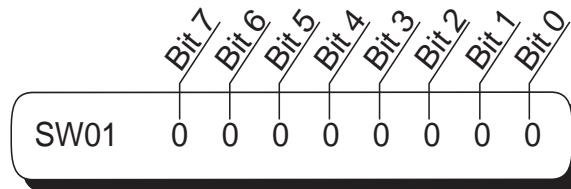

Figure 1-30 Bit Switch Display

See the chart in the service data shown in this Chapter, 5.2.3 Service data setting to see effective bits and their default values. The meanings (functions) of the bits are not described in this manual except the new switches added to this model. See the G3 Facsimile Service Data Handbook (supplied separately) for details of the switches.

Below are examples showing how to read bit switch tables.

| Bit | Function | 1 | 0 |
|-----|---------------------------------|--------|-------------------|
| 0 | Service error code | Output | Not Output |
| 1 | Error dump list | Output | Not Output |
| 2 | Not used | | |
| 3 | Not used | | |
| 4 | ##300 series service error code | Output | Not Output |
| 5 | Not used | | |
| 6 | Not used | | |
| 7 | Not used | | |

Indicates that the setting is "1".

Indicates that the setting is "0".

Figures in boldface are default settings.

Figure 1-31 How to Read Bit Switch Tables

3-5-6 New SSSWs/parameters added to this model

#1 SSSW (service soft switch setting)

SW01 (service soft switch 01: error management)

| Bit | Function | 1 | 0 |
|------------|-----------------------------------|----------|-------------------|
| 0 | Service error code | Output | Not output |
| 1 | Error dump list | Output | Not output |
| 2 | Not used | | |
| 3 | Not used | | |
| 4 (New) | # # 300 series service error code | Output | Not output |
| 5 | Not used | | |
| 6 | Not used | | |
| 7 | Not used | | |

[Bit 4]

Even when Bit0 is set to " Not output" , you can select whether or not to output # # 300 series Service Error Codes, caused by hardware malfunction.

When " Output" is selected, # # 300 series Service Error Codes are displayed and in reports.

When " Not Output" is selected, no Service Error Codes are displayed.

SW29 Flash ROM version up

| Bit | Function | 1 | 0 |
|------------|----------------------|----------|-----------|
| 0 | Not used | | |
| 1 (New) | Flash ROM version up | YES | NO |
| 2 | Not used | | |
| 3 | Not used | | |
| 4 | Not used | | |
| 5 | Not used | | |
| 6 | Not used | | |
| 7 | Not used | | |

[Bit 1]

If YES is selected, the version of Update flash ROM can be upgraded.

#7 PRINTER (printer function settings)

2. NUMERIC PARAM.

| No. | Function | Selecting range | Default setting |
|------------|----------------------|------------------------|------------------------|
| 05 | Trailing edge margin | 0 ~ 9999 | 5 (5 mm) |

[Parameter 05]

Sets the print image trailing edge margin.

5. INK ABS CAPA

This switch allows the waste ink capacity stored in the PCNT board to be checked or entered.

[SUCTION]

At # 5 INK ABS CAPA, you can check or register the capacity of waste ink ejected during the cleaning operation. For the waste ink capacity registration, register a value between 0 – 100 (%) with the numeric keys.

The absorption amount of the waste ink absorber is set based upon the amount that the BJ cartridge has ejected.

The settings of the waste ink capacity are stored in EEPROM of SPCNT BOARD.

When replacing the SPCNT BOARD, check the waste ink capacity before the replacement, and register the waste ink capacity at the new SPCNT BOARD after the replacement.

6.CDR ADJUST

At # 6 CDR ADJ UST (CD-R Print writing position adjustment), you can adjust the writing position in X and Y directions within the following range.

+/-0.0mm, +/-0.1mm, +/-0.2mm, +/-0.4mm, +/-0.6mm, +/-0.8mm, +/-1.0mm

You can also perform this adjustment from “ CD-LabelPrint” or “ Easy-PhotoPrint” .

3-5-7 SSSW Default Setting

| TYPE | U.S.A. | EUROPE | U.K. | SWEDEN | SWISS | AUSTRIA |
|----------------|----------|----------|----------|----------|----------|----------|
| #1 SSSW | | | | | | |
| SW01 | 00000000 | 00010000 | 00010000 | 00010000 | 00010000 | 00010000 |
| SW02 | 00000000 | 00000000 | 00000000 | 00000000 | 00000000 | 00000000 |
| SW03 | 00000000 | 00000000 | 00000000 | 00000000 | 00000000 | 00000000 |
| SW04 | 10000000 | 10000000 | 10000000 | 10000000 | 10000010 | 10000010 |
| SW05 | 00000000 | 00000000 | 00000000 | 00000000 | 00000000 | 00000000 |
| SW06 | 10010000 | 10000000 | 10000000 | 10000000 | 10000000 | 10000000 |
| SW07 | 00000000 | 00000000 | 00000000 | 00000000 | 00000000 | 00000000 |
| SW08 | 00000000 | 00000000 | 00000000 | 00000000 | 00000000 | 00000000 |
| SW09 | 00000000 | 00000000 | 00000000 | 00000000 | 00000000 | 00000000 |
| SW10 | 00000000 | 00000000 | 00000000 | 00000000 | 00000000 | 00000000 |
| SW11 | 00000000 | 00000000 | 00000000 | 00000000 | 00000000 | 00000000 |
| SW12 | 00000010 | 00000010 | 00000010 | 00000010 | 00000010 | 00000010 |
| SW13 | 00000000 | 00000000 | 00000000 | 00000000 | 00000000 | 00000000 |
| SW14 | 00000000 | 00000000 | 00000000 | 00000000 | 00000000 | 00000000 |
| SW15 | 00000000 | 00000000 | 01000000 | 00000000 | 00000000 | 00000000 |
| SW16 | 00000011 | 00000011 | 00000011 | 00000011 | 00000011 | 00000011 |
| SW17 | 00000000 | 00000000 | 00000000 | 00000000 | 00000000 | 00000000 |
| SW18 | 00000000 | 00000000 | 00000000 | 00000000 | 00000000 | 00000000 |
| SW19 | 00000000 | 00000000 | 00000000 | 00000000 | 00000000 | 00000000 |
| SW20 | 10000000 | 10000000 | 10000000 | 10000000 | 10000000 | 10000000 |
| SW21 | 00000000 | 00000000 | 00000000 | 00000000 | 00000000 | 00000000 |
| SW22 | 00000000 | 00000000 | 00000000 | 00000000 | 00000000 | 00000000 |
| SW23 | 00000000 | 00000000 | 00000000 | 00000000 | 00000000 | 00000000 |
| SW24 | 00000000 | 00000000 | 00000000 | 00000000 | 00000000 | 00000000 |
| SW25 | 00001000 | 00001000 | 00001000 | 00001000 | 00001000 | 00001001 |
| SW26 | 00000000 | 00000000 | 00000000 | 00000000 | 00000000 | 00000000 |
| SW27 | 00000000 | 00000000 | 00000000 | 00000000 | 00000000 | 00000000 |
| SW28 | 00000000 | 00000000 | 00000000 | 00000000 | 00000000 | 00000000 |
| SW29 | 00000000 | 00000000 | 00000000 | 00000000 | 00000000 | 00000000 |
| SW30 | 00000000 | 00000000 | 00000000 | 00000000 | 00000000 | 00000000 |

| TYPE | U.S.A. | EUROPE | U.K. | SWEDEN | SWISS | AUSTRIA |
|----------------|---------|---------|---------|---------|---------|---------|
| SW31 | 0000000 | 0000000 | 0000000 | 0000000 | 0000000 | 0000000 |
| SW32 | 0000000 | 0000000 | 0000000 | 0000000 | 0000000 | 0000000 |
| SW33 | 0000000 | 0000000 | 0000000 | 0000000 | 0000000 | 0000000 |
| SW34 | 0000000 | 0000000 | 0000000 | 0000000 | 0000000 | 0000000 |
| SW35 | 0000000 | 0000000 | 0000000 | 0000000 | 0000000 | 0000000 |
| SW36 | 0000000 | 0000000 | 0000000 | 0000000 | 0000000 | 0000000 |
| SW37 | 0000000 | 0000000 | 0000000 | 0000000 | 0000000 | 0000000 |
| SW38 | 0000000 | 0000000 | 0000000 | 0000000 | 0000000 | 0000000 |
| SW39 | 0000000 | 0000000 | 0000000 | 0000000 | 0000000 | 0000000 |
| SW40 | 0000000 | 0000000 | 0000000 | 0000000 | 0000000 | 0000000 |
| SW41 | 0000000 | 0000000 | 0000000 | 0000000 | 0000000 | 0000000 |
| SW42 | 0000000 | 0000000 | 0000000 | 0000000 | 0000000 | 0000000 |
| SW43 | 0000000 | 0000000 | 0000000 | 0000000 | 0000000 | 0000000 |
| SW44 | 0000000 | 0000000 | 0000000 | 0000000 | 0000000 | 0000000 |
| SW45 | 0000000 | 0000000 | 0000000 | 0000000 | 0000000 | 0000000 |
| SW46 | 0000000 | 0000000 | 0000000 | 0000000 | 0000000 | 0000000 |
| SW47 | 0000000 | 0000000 | 0000000 | 0000000 | 0000000 | 0000000 |
| SW48 | 0000000 | 0000000 | 0000000 | 0000000 | 0000000 | 0000000 |
| SW49 | 0000000 | 0000000 | 0000000 | 0000000 | 0000000 | 0000000 |
| SW50 | 0000000 | 0000000 | 0000000 | 0000000 | 0000000 | 0000000 |
| #2 MENU | | | | | | |
| 05: | OFF | OFF | OFF | OFF | OFF | OFF |
| 06: | DIAL | DIAL | DIAL | DIAL | DIAL | DIAL |
| 07: | 10 | 10 | 10 | 10 | 10 | 10 |
| 08: | 3429 | 3429 | 3429 | 3429 | 3429 | 3429 |
| 09: | 33.6 | 33.6 | 33.6 | 33.6 | 33.6 | 33.6 |
| 10: | 25 Hz | 25 Hz | 25 Hz | 25 Hz | 25 Hz | 25 Hz |

| TYPE | DENMARK | NORWAY | HOLLAND | BELGIUM | AUSTRALIA | FINLAND |
|----------------|----------|----------|----------|----------|-----------|----------|
| #1 SSSW | | | | | | |
| SW01 | 00010000 | 00010000 | 00010000 | 00010000 | 00010000 | 00010001 |
| SW02 | 00000000 | 00000000 | 00000000 | 00000000 | 00000000 | 00000000 |
| SW03 | 00000000 | 00000000 | 00000000 | 00000000 | 00000000 | 00000000 |
| SW04 | 10000000 | 10000010 | 10000010 | 10000000 | 10000000 | 10000000 |
| SW05 | 00000000 | 00000000 | 00000000 | 00000000 | 00000000 | 00000000 |
| SW06 | 10000000 | 10000000 | 10000000 | 10000000 | 10000000 | 10000000 |
| SW07 | 00000000 | 00000000 | 00000000 | 00000000 | 00000000 | 00000000 |
| SW08 | 00000000 | 00000000 | 00000000 | 00000000 | 00000000 | 00000000 |
| SW09 | 00000000 | 00000000 | 00000000 | 00000000 | 00000000 | 00000000 |
| SW10 | 00000000 | 00000000 | 00000000 | 00000000 | 00000000 | 00000000 |
| SW11 | 00000000 | 00000000 | 00000000 | 00000000 | 00000000 | 00000000 |
| SW12 | 00000010 | 00000010 | 00000010 | 00000010 | 00000010 | 00000010 |
| SW13 | 00000000 | 00000000 | 00000000 | 00000000 | 00000000 | 00000000 |
| SW14 | 00000000 | 00000000 | 00000000 | 00000000 | 00000000 | 00000000 |
| SW15 | 00000000 | 00000000 | 00000000 | 00000000 | 00000000 | 00000000 |
| SW16 | 00000011 | 00000011 | 00000011 | 00000011 | 00000011 | 00000011 |
| SW17 | 00000000 | 00000000 | 00000000 | 00000000 | 00000000 | 00000000 |
| SW18 | 00000000 | 00000000 | 00000000 | 00000000 | 00000000 | 00000000 |
| SW19 | 00000000 | 00000000 | 00000000 | 00000000 | 00000000 | 00000000 |
| SW20 | 10000000 | 10000000 | 10000000 | 10000000 | 10000000 | 10000000 |
| SW21 | 00000000 | 00000000 | 00000000 | 00000000 | 00000000 | 00000000 |
| SW22 | 00000000 | 00000000 | 00000000 | 00000000 | 00000000 | 00000000 |
| SW23 | 00000000 | 00000000 | 00000000 | 00000000 | 00000000 | 00000000 |
| SW24 | 00000000 | 00000000 | 00000000 | 00000000 | 00000000 | 00000000 |
| SW25 | 00001000 | 00001000 | 00001000 | 00001000 | 00001000 | 00001000 |
| SW26 | 00000000 | 00000000 | 00000000 | 00000000 | 00000000 | 00000000 |
| SW27 | 00000000 | 00000000 | 00000000 | 00000000 | 00000000 | 00000000 |
| SW28 | 00000000 | 00000000 | 00000000 | 00000000 | 00000000 | 00000000 |
| SW29 | 00000000 | 00000000 | 00000000 | 00000000 | 00000000 | 00000000 |
| SW30 | 00000000 | 00000000 | 00000000 | 00000000 | 00000000 | 00000000 |

| TYPE | DENMARK | NORWAY | HOLLAND | BELGIUM | AUSTRALIA | FINLAND |
|----------------|---------|---------|---------|---------|-----------|---------|
| SW31 | 0000000 | 0000000 | 0000000 | 0000000 | 0000000 | 0000000 |
| SW32 | 0000000 | 0000000 | 0000000 | 0000000 | 0000000 | 0000000 |
| SW33 | 0000000 | 0000000 | 0000000 | 0000000 | 0000000 | 0000000 |
| SW34 | 0000000 | 0000000 | 0000000 | 0000000 | 0000000 | 0000000 |
| SW35 | 0000000 | 0000000 | 0000000 | 0000000 | 0000000 | 0000000 |
| SW36 | 0000000 | 0000000 | 0000000 | 0000000 | 0000000 | 0000000 |
| SW37 | 0000000 | 0000000 | 0000000 | 0000000 | 0000000 | 0000000 |
| SW38 | 0000000 | 0000000 | 0000000 | 0000000 | 0000000 | 0000000 |
| SW39 | 0000000 | 0000000 | 0000000 | 0000000 | 0000000 | 0000000 |
| SW40 | 0000000 | 0000000 | 0000000 | 0000000 | 0000000 | 0000000 |
| SW41 | 0000000 | 0000000 | 0000000 | 0000000 | 0000000 | 0000000 |
| SW42 | 0000000 | 0000000 | 0000000 | 0000000 | 0000000 | 0000000 |
| SW43 | 0000000 | 0000000 | 0000000 | 0000000 | 0000000 | 0000000 |
| SW44 | 0000000 | 0000000 | 0000000 | 0000000 | 0000000 | 0000000 |
| SW45 | 0000000 | 0000000 | 0000000 | 0000000 | 0000000 | 0000000 |
| SW46 | 0000000 | 0000000 | 0000000 | 0000000 | 0000000 | 0000000 |
| SW47 | 0000000 | 0000000 | 0000000 | 0000000 | 0000000 | 0000000 |
| SW48 | 0000000 | 0000000 | 0000000 | 0000000 | 0000000 | 0000000 |
| SW49 | 0000000 | 0000000 | 0000000 | 0000000 | 0000000 | 0000000 |
| SW50 | 0000000 | 0000000 | 0000000 | 0000000 | 0000000 | 0000000 |
| #2 MENU | | | | | | |
| 05: | OFF | OFF | OFF | OFF | OFF | OFF |
| 06: | DIAL | DIAL | DIAL | DIAL | DIAL | DIAL |
| 07: | 10 | 10 | 10 | 10 | 10 | 10 |
| 08: | 3429 | 3429 | 3429 | 3429 | 3429 | 3429 |
| 09: | 33.6 | 33.6 | 33.6 | 33.6 | 33.6 | 33.6 |
| 10: | 25 Hz | 25 Hz | 25 Hz | 25 Hz | 25 Hz | 25 Hz |

| TYPE | N.Z | ITALY | SPAIN | PORTUGAL | IRELAND | HONG KONG |
|----------------|----------|----------|----------|----------|----------|-----------|
| #1 SSSW | | | | | | |
| SW01 | 00010000 | 00010000 | 00010000 | 00010000 | 00010000 | 00010000 |
| SW02 | 00000000 | 00000000 | 00000000 | 00000000 | 00000000 | 00000000 |
| SW03 | 00000000 | 00000000 | 00000000 | 00000000 | 00000000 | 00000000 |
| SW04 | 10000000 | 10000010 | 10000010 | 10000010 | 10000000 | 10000000 |
| SW05 | 00000000 | 00000000 | 00000000 | 00000000 | 00000000 | 00000000 |
| SW06 | 10000000 | 10000000 | 10000000 | 10000000 | 10000000 | 10000000 |
| SW07 | 00000000 | 00000000 | 00000000 | 00000000 | 00000000 | 00000000 |
| SW08 | 00000000 | 00000000 | 00000000 | 00000000 | 00000000 | 00000000 |
| SW09 | 00000000 | 00000000 | 00000000 | 00000000 | 00000000 | 01000000 |
| SW10 | 00000000 | 00000000 | 00000000 | 00000000 | 00000000 | 00000000 |
| SW11 | 00000000 | 00000000 | 00000000 | 00000000 | 00000000 | 00000000 |
| SW12 | 00000010 | 00000010 | 00000010 | 00000010 | 00000010 | 00000010 |
| SW13 | 00000000 | 00000000 | 00000000 | 00000000 | 00000000 | 00000000 |
| SW14 | 00000000 | 00000000 | 00000000 | 00000000 | 00000000 | 00000000 |
| SW15 | 00000000 | 00000000 | 00000000 | 00000000 | 00000000 | 00000000 |
| SW16 | 00000011 | 00000011 | 00000011 | 00000011 | 00000011 | 00000011 |
| SW17 | 00000000 | 00000000 | 00000000 | 00000000 | 00000000 | 00000000 |
| SW18 | 00000000 | 00000000 | 00000000 | 00000000 | 00000000 | 00000000 |
| SW19 | 00000000 | 00000000 | 00000000 | 00000000 | 00000000 | 00000000 |
| SW20 | 10000000 | 10000000 | 10000000 | 10000000 | 10000000 | 10000000 |
| SW21 | 00000000 | 00000000 | 00000000 | 00000000 | 00000000 | 00000000 |
| SW22 | 00000000 | 00000000 | 00000000 | 00000000 | 00000000 | 00000000 |
| SW23 | 00000000 | 00000000 | 00000000 | 00000000 | 00000000 | 00000000 |
| SW24 | 00000000 | 00000000 | 00000000 | 00000000 | 00000000 | 00000000 |
| SW25 | 00001000 | 00001000 | 00001001 | 00001000 | 00001000 | 00001000 |
| SW26 | 00000000 | 10000000 | 00000000 | 00000000 | 00000000 | 00000000 |
| SW27 | 00000000 | 00000000 | 00000000 | 00000000 | 00000000 | 00000000 |
| SW28 | 00000000 | 00000000 | 00000000 | 00000000 | 00000000 | 00000000 |
| SW29 | 00000000 | 00000000 | 00000000 | 00000000 | 00000000 | 00000000 |
| SW30 | 00000000 | 00000000 | 00000000 | 00000000 | 00000000 | 00000000 |

| TYPE | N.Z | ITALY | SPAIN | PORTUGAL | IRELAND | HONG KONG |
|----------------|---------|---------|---------|----------|---------|-----------|
| SW31 | 0000000 | 0000000 | 0000000 | 0000000 | 0000000 | 0000000 |
| SW32 | 0000000 | 0000000 | 0000000 | 0000000 | 0000000 | 0000000 |
| SW33 | 0000000 | 0000000 | 0000000 | 0000000 | 0000000 | 0000000 |
| SW34 | 0000000 | 0000000 | 0000000 | 0000000 | 0000000 | 0000000 |
| SW35 | 0000000 | 0000000 | 0000000 | 0000000 | 0000000 | 0000000 |
| SW36 | 0000000 | 0000000 | 0000000 | 0000000 | 0000000 | 0000000 |
| SW37 | 0000000 | 0000000 | 0000000 | 0000000 | 0000000 | 0000000 |
| SW38 | 0000000 | 0000000 | 0000000 | 0000000 | 0000000 | 0000000 |
| SW39 | 0000000 | 0000000 | 0000000 | 0000000 | 0000000 | 0000000 |
| SW40 | 0000000 | 0000000 | 0000000 | 0000000 | 0000000 | 0000000 |
| SW41 | 0000000 | 0000000 | 0000000 | 0000000 | 0000000 | 0000000 |
| SW42 | 0000000 | 0000000 | 0000000 | 0000000 | 0000000 | 0000000 |
| SW43 | 0000000 | 0000000 | 0000000 | 0000000 | 0000000 | 0000000 |
| SW44 | 0000000 | 0000000 | 0000000 | 0000000 | 0000000 | 0000000 |
| SW45 | 0000000 | 0000000 | 0000000 | 0000000 | 0000000 | 0000000 |
| SW46 | 0000000 | 0000000 | 0000000 | 0000000 | 0000000 | 0000000 |
| SW47 | 0000000 | 0000000 | 0000000 | 0000000 | 0000000 | 0000000 |
| SW48 | 0000000 | 0000000 | 0000000 | 0000000 | 0000000 | 0000000 |
| SW49 | 0000000 | 0000000 | 0000000 | 0000000 | 0000000 | 0000000 |
| SW50 | 0000000 | 0000000 | 0000000 | 0000000 | 0000000 | 0000000 |
| #2 MENU | | | | | | |
| 05: | OFF | OFF | OFF | OFF | OFF | OFF |
| 06: | DIAL | DIAL | DIAL | DIAL | DIAL | DIAL |
| 07: | 10 | 10 | 10 | 10 | 10 | 10 |
| 08: | 3429 | 3429 | 3429 | 3429 | 3429 | 3429 |
| 09: | 33.6 | 33.6 | 33.6 | 33.6 | 33.6 | 33.6 |
| 10: | 25 Hz | 25 Hz | 25 Hz | 25 Hz | 25 Hz | 25 Hz |

| TYPE | MALAYSIA | HUNGARY | SAF | KOREA | CHINA | GERMAN |
|----------------|----------|----------|----------|----------|----------|----------|
| #1 SSSW | | | | | | |
| SW01 | 00010000 | 00010000 | 00010000 | 00010000 | 00010000 | 00010000 |
| SW02 | 00000000 | 00000000 | 00000000 | 00000000 | 00000000 | 00000000 |
| SW03 | 00000000 | 00000000 | 00000000 | 00000000 | 00000001 | 00000000 |
| SW04 | 10000000 | 10000000 | 10000000 | 10000000 | 10000000 | 00000010 |
| SW05 | 00000000 | 00000000 | 00000000 | 00000000 | 00000000 | 00000000 |
| SW06 | 10000000 | 10000000 | 10000000 | 10000000 | 10000000 | 10000000 |
| SW07 | 00000000 | 00000000 | 00000000 | 00000000 | 00000000 | 00000000 |
| SW08 | 00000000 | 00000000 | 00000000 | 00000000 | 00000000 | 00000000 |
| SW09 | 01000000 | 00000000 | 01000000 | 01000000 | 01000000 | 00000000 |
| SW10 | 00000000 | 00000000 | 00000000 | 00000000 | 00000000 | 00000000 |
| SW11 | 00000000 | 00000000 | 00000000 | 00000000 | 00000000 | 00000000 |
| SW12 | 00000010 | 00000010 | 00000010 | 00000010 | 00000010 | 00000010 |
| SW13 | 00000000 | 00000000 | 00000000 | 00000000 | 00000000 | 00000000 |
| SW14 | 00000000 | 00000000 | 00000000 | 00000000 | 00000000 | 00000000 |
| SW15 | 00000000 | 00000000 | 00000000 | 00000000 | 00000000 | 00000000 |
| SW16 | 00000011 | 00000011 | 00000011 | 00000011 | 00000011 | 00000011 |
| SW17 | 00000000 | 00000000 | 00000000 | 00000000 | 00000000 | 00000000 |
| SW18 | 00000000 | 00000000 | 00000000 | 00000000 | 00000000 | 00000000 |
| SW19 | 00000000 | 00000000 | 00000000 | 00000000 | 00000000 | 00000000 |
| SW20 | 10000000 | 10000000 | 10000000 | 10000000 | 10000000 | 10000000 |
| SW21 | 00000000 | 00000000 | 00000000 | 00000000 | 00000000 | 00000000 |
| SW22 | 00000000 | 00000000 | 00000000 | 00000000 | 00000000 | 00001000 |
| SW23 | 00000000 | 00000000 | 00000000 | 00000000 | 00000000 | 00000000 |
| SW24 | 00000000 | 00000000 | 00000000 | 00000000 | 00000000 | 00000000 |
| SW25 | 00001000 | 00001000 | 00001000 | 00001000 | 00001000 | 00001101 |
| SW26 | 00000000 | 00000000 | 00000000 | 00000000 | 00000000 | 00010000 |
| SW27 | 00000000 | 00000000 | 00000000 | 00000000 | 00000000 | 00000000 |
| SW28 | 00000000 | 00000000 | 00000000 | 00000000 | 00000000 | 00000000 |
| SW29 | 00000000 | 00000000 | 00000000 | 00000000 | 00000000 | 00000000 |
| SW30 | 00000000 | 00000000 | 00000000 | 00000000 | 00000000 | 00000000 |

| TYPE | MALAYSIA | HUNGARY | SAF | KOREA | CHINA | GERMAN |
|----------------|----------|---------|---------|---------|---------|---------|
| SW31 | 0000000 | 0000000 | 0000000 | 0000000 | 0000000 | 0000000 |
| SW32 | 0000000 | 0000000 | 0000000 | 0000000 | 0000000 | 0000000 |
| SW33 | 0000000 | 0000000 | 0000000 | 0000000 | 0000000 | 0000000 |
| SW34 | 0000000 | 0000000 | 0000000 | 0000000 | 0000000 | 0000000 |
| SW35 | 0000000 | 0000000 | 0000000 | 0000000 | 0000000 | 0000000 |
| SW36 | 0000000 | 0000000 | 0000000 | 0000000 | 0000000 | 0000000 |
| SW37 | 0000000 | 0000000 | 0000000 | 0000000 | 0000000 | 0000000 |
| SW38 | 0000000 | 0000000 | 0000000 | 0000000 | 0000000 | 0000000 |
| SW39 | 0000000 | 0000000 | 0000000 | 0000000 | 0000000 | 0000000 |
| SW40 | 0000000 | 0000000 | 0000000 | 0000000 | 0000000 | 0000000 |
| SW41 | 0000000 | 0000000 | 0000000 | 0000000 | 0000000 | 0000000 |
| SW42 | 0000000 | 0000000 | 0000000 | 0000000 | 0000000 | 0000000 |
| SW43 | 0000000 | 0000000 | 0000000 | 0000000 | 0000000 | 0000000 |
| SW44 | 0000000 | 0000000 | 0000000 | 0000000 | 0000000 | 0000000 |
| SW45 | 0000000 | 0000000 | 0000000 | 0000000 | 0000000 | 0000000 |
| SW46 | 0000000 | 0000000 | 0000000 | 0000000 | 0000000 | 0000000 |
| SW47 | 0000000 | 0000000 | 0000000 | 0000000 | 0000000 | 0000000 |
| SW48 | 0000000 | 0000000 | 0000000 | 0000000 | 0000000 | 0000000 |
| SW49 | 0000000 | 0000000 | 0000000 | 0000000 | 0000000 | 0000000 |
| SW50 | 0000000 | 0000000 | 0000000 | 0000000 | 0000000 | 0000000 |
| #2 MENU | | | | | | |
| 05: | OFF | OFF | OFF | OFF | OFF | OFF |
| 06: | DIAL | DIAL | DIAL | DIAL | DIAL | DIAL |
| 07: | 10 | 10 | 10 | 11 | 13 | 10 |
| 08: | 3429 | 3429 | 3429 | 3429 | 3429 | 3429 |
| 09: | 33.6 | 33.6 | 33.6 | 33.6 | 33.6 | 33.6 |
| 10: | 25 Hz | 25 Hz | 25 Hz | 25 Hz | 25 Hz | 25 Hz |

| TYPE | FRANCE | SINGAPORE | CZECH | SLOVENIA | CANADA | J APAN |
|----------------|----------|-----------|----------|----------|----------|----------|
| #1 SSSW | | | | | | |
| SW01 | 00010000 | 00010000 | 00010000 | 00010000 | 00000000 | 00010000 |
| SW02 | 00000000 | 00000000 | 00000000 | 00000000 | 00000000 | 00000000 |
| SW03 | 00000000 | 00000000 | 00000000 | 00000000 | 00000000 | 00000000 |
| SW04 | 00000010 | 10000000 | 10000000 | 10000000 | 10000000 | 10000000 |
| SW05 | 00000000 | 00000000 | 00000000 | 00000000 | 00000000 | 00000000 |
| SW06 | 10000000 | 10000000 | 10000000 | 10000000 | 10010000 | 10000000 |
| SW07 | 00000000 | 00000000 | 00000000 | 00000000 | 00000000 | 00000000 |
| SW08 | 00000000 | 00000000 | 00000000 | 00000000 | 00000000 | 00000000 |
| SW09 | 00000000 | 01000000 | 00000000 | 00000000 | 00000000 | 01000000 |
| SW10 | 00000000 | 00000000 | 00000000 | 00000000 | 00000000 | 00000000 |
| SW11 | 00000000 | 00000000 | 00000000 | 00000000 | 00000000 | 00000000 |
| SW12 | 00000010 | 00000010 | 00000010 | 00000010 | 00000010 | 00000010 |
| SW13 | 00000000 | 00000000 | 00000000 | 00000000 | 00000000 | 00000000 |
| SW14 | 00000000 | 00000000 | 00000000 | 00000000 | 00000000 | 00000000 |
| SW15 | 00000000 | 00000000 | 00000000 | 00000000 | 00000000 | 00000000 |
| SW16 | 00000011 | 00000011 | 00000011 | 00000011 | 00000011 | 00000011 |
| SW17 | 00000000 | 00000000 | 00000000 | 00000000 | 00000000 | 00000000 |
| SW18 | 00000000 | 00000000 | 00000000 | 00000000 | 00000000 | 00000000 |
| SW19 | 00000000 | 00000000 | 00000000 | 00000000 | 00000000 | 00000000 |
| SW20 | 10000000 | 10000000 | 10000000 | 10000000 | 10000000 | 10000000 |
| SW21 | 00000000 | 00000000 | 00000000 | 00000000 | 00000000 | 00000000 |
| SW22 | 00000000 | 00000000 | 00000000 | 00000000 | 00000000 | 00000000 |
| SW23 | 00000000 | 00000000 | 00000000 | 00000000 | 00000000 | 00000000 |
| SW24 | 00000000 | 00000000 | 00000000 | 00000000 | 00000000 | 00000000 |
| SW25 | 00001001 | 00001000 | 00001000 | 00001000 | 00001000 | 00000000 |
| SW26 | 00000000 | 00000000 | 00000000 | 00000000 | 00000000 | 00000000 |
| SW27 | 00000000 | 00000000 | 00000000 | 00000000 | 00000000 | 00000000 |
| SW28 | 00000000 | 00000000 | 00000000 | 00000000 | 00000000 | 00000000 |
| SW29 | 00000000 | 00000000 | 00000000 | 00000000 | 00000000 | 00000000 |
| SW30 | 00000000 | 00000000 | 00000000 | 00000000 | 00000000 | 00000000 |

| TYPE | FRANCE | SINGAPORE | CZECH | SLOVENIA | CANADA | J APAN |
|----------------|---------|-----------|---------|----------|---------|---------|
| SW31 | 0000000 | 0000000 | 0000000 | 0000000 | 0000000 | 0000000 |
| SW32 | 0000000 | 0000000 | 0000000 | 0000000 | 0000000 | 0000001 |
| SW33 | 0000000 | 0000000 | 0000000 | 0000000 | 0000000 | 0000000 |
| SW34 | 0000000 | 0000000 | 0000000 | 0000000 | 0000000 | 0000000 |
| SW35 | 0000000 | 0000000 | 0000000 | 0000000 | 0000000 | 0000000 |
| SW36 | 0000000 | 0000000 | 0000000 | 0000000 | 0000000 | 0000000 |
| SW37 | 0000000 | 0000000 | 0000000 | 0000000 | 0000000 | 0000000 |
| SW38 | 0000000 | 0000000 | 0000000 | 0000000 | 0000000 | 0000000 |
| SW39 | 0000000 | 0000000 | 0000000 | 0000000 | 0000000 | 0000000 |
| SW40 | 0000000 | 0000000 | 0000000 | 0000000 | 0000000 | 0000000 |
| SW41 | 0000000 | 0000000 | 0000000 | 0000000 | 0000000 | 0000000 |
| SW42 | 0000000 | 0000000 | 0000000 | 0000000 | 0000000 | 0000000 |
| SW43 | 0000000 | 0000000 | 0000000 | 0000000 | 0000000 | 0000000 |
| SW44 | 0000000 | 0000000 | 0000000 | 0000000 | 0000000 | 0000000 |
| SW45 | 0000000 | 0000000 | 0000000 | 0000000 | 0000000 | 0000000 |
| SW46 | 0000000 | 0000000 | 0000000 | 0000000 | 0000000 | 0000000 |
| SW47 | 0000000 | 0000000 | 0000000 | 0000000 | 0000000 | 0000000 |
| SW48 | 0000000 | 0000000 | 0000000 | 0000000 | 0000000 | 0000000 |
| SW49 | 0000000 | 0000000 | 0000000 | 0000000 | 0000000 | 0000000 |
| SW50 | 0000000 | 0000000 | 0000000 | 0000000 | 0000000 | 0000000 |
| #1 MENU | | | | | | |
| 05: | OFF | OFF | OFF | OFF | OFF | OFF |
| 06: | DIAL | DIAL | DIAL | DIAL | DIAL | DIAL |
| 07: | 10 | 10 | 10 | 10 | 10 | 10 |
| 08: | 3429 | 3429 | 3429 | 3429 | 3429 | 3429 |
| 09: | 33.6 | 33.6 | 33.6 | 33.6 | 33.6 | 33.6 |
| 10: | 50 Hz | 25 Hz | 25 Hz | 25 Hz | 25 Hz | 25 Hz |

| TYPE | RUSSIA | ASIA | POLAND | EUROPE2 | STANDARD |
|----------------|----------|----------|----------|----------|----------|
| #1 SSSW | | | | | |
| SW01 | 00010000 | 00010000 | 00010000 | 00010000 | 00010000 |
| SW02 | 00000000 | 00000000 | 00000000 | 00000000 | 00000000 |
| SW03 | 00000000 | 00000000 | 00000000 | 00000000 | 00000000 |
| SW04 | 10000000 | 10000000 | 10000000 | 10000000 | 10000000 |
| SW05 | 00000000 | 00000000 | 00000000 | 00000000 | 00000000 |
| SW06 | 10000000 | 10000000 | 10000000 | 10000000 | 10000000 |
| SW07 | 00000000 | 00000000 | 00000000 | 00000000 | 00000000 |
| SW08 | 00000000 | 00000000 | 00000000 | 00000000 | 00000000 |
| SW09 | 00000000 | 00000000 | 00000000 | 00000000 | 00000000 |
| SW10 | 00000000 | 00000000 | 00000000 | 00000000 | 00000000 |
| SW11 | 00000000 | 00000000 | 00000000 | 00000000 | 00000000 |
| SW12 | 00000010 | 00000010 | 00000010 | 00000010 | 00000010 |
| SW13 | 00000000 | 00000000 | 00000000 | 00000000 | 00000000 |
| SW14 | 00000000 | 00000000 | 00000000 | 00000000 | 00000000 |
| SW15 | 00000000 | 00000000 | 00000000 | 00000000 | 00000000 |
| SW16 | 00000011 | 00000011 | 00000011 | 00000011 | 00000011 |
| SW17 | 00000000 | 00000000 | 00000000 | 00000000 | 00000000 |
| SW18 | 00000000 | 00000000 | 00000000 | 00000000 | 00000000 |
| SW19 | 00000000 | 00000000 | 00000000 | 00000000 | 00000000 |
| SW20 | 10000000 | 10000000 | 10000000 | 10000000 | 10000000 |
| SW21 | 00000000 | 00000000 | 00000000 | 00000000 | 00000000 |
| SW22 | 00000000 | 00000000 | 00000000 | 00000000 | 00000000 |
| SW23 | 00000000 | 00000000 | 00000000 | 00000000 | 00000000 |
| SW24 | 00000000 | 00000000 | 00000000 | 00000000 | 00000000 |
| SW25 | 00001000 | 00001000 | 00001000 | 00001000 | 00001000 |
| SW26 | 00000000 | 00000000 | 00000000 | 00000000 | 00000000 |
| SW27 | 00000000 | 00000000 | 00000000 | 00000000 | 00000000 |
| SW28 | 00000000 | 00000000 | 00000000 | 00000000 | 00000000 |
| SW29 | 00000000 | 00000000 | 00000000 | 00000000 | 00000000 |
| SW30 | 00000000 | 00000000 | 00000000 | 00000000 | 00000000 |

| TYPE | RUSSIA | ASIA | POLAND | EUROPE2 | STANDARD |
|----------------|---------|---------|---------|---------|----------|
| SW31 | 0000000 | 0000000 | 0000000 | 0000000 | 0000000 |
| SW32 | 0000000 | 0000000 | 0000000 | 0000000 | 0000000 |
| SW33 | 0000000 | 0000000 | 0000000 | 0000000 | 0000000 |
| SW34 | 0000000 | 0000000 | 0000000 | 0000000 | 0000000 |
| SW35 | 0000000 | 0000000 | 0000000 | 0000000 | 0000000 |
| SW36 | 0000000 | 0000000 | 0000000 | 0000000 | 0000000 |
| SW37 | 0000000 | 0000000 | 0000000 | 0000000 | 0000000 |
| SW38 | 0000000 | 0000000 | 0000000 | 0000000 | 0000000 |
| SW39 | 0000000 | 0000000 | 0000000 | 0000000 | 0000000 |
| SW40 | 0000000 | 0000000 | 0000000 | 0000000 | 0000000 |
| SW41 | 0000000 | 0000000 | 0000000 | 0000000 | 0000000 |
| SW42 | 0000000 | 0000000 | 0000000 | 0000000 | 0000000 |
| SW43 | 0000000 | 0000000 | 0000000 | 0000000 | 0000000 |
| SW44 | 0000000 | 0000000 | 0000000 | 0000000 | 0000000 |
| SW45 | 0000000 | 0000000 | 0000000 | 0000000 | 0000000 |
| SW46 | 0000000 | 0000000 | 0000000 | 0000000 | 0000000 |
| SW47 | 0000000 | 0000000 | 0000000 | 0000000 | 0000000 |
| SW48 | 0000000 | 0000000 | 0000000 | 0000000 | 0000000 |
| SW49 | 0000000 | 0000000 | 0000000 | 0000000 | 0000000 |
| SW50 | 0000000 | 0000000 | 0000000 | 0000000 | 0000000 |
| #1 MENU | | | | | |
| 05: | OFF | OFF | OFF | OFF | OFF |
| 06: | DIAL | DIAL | DIAL | DIAL | DIAL |
| 07: | 10 | 10 | 10 | 10 | 10 |
| 08: | 3429 | 3429 | 3429 | 3429 | 3429 |
| 09: | 33.6 | 33.6 | 33.6 | 33.6 | 33.6 |
| 10: | 25 Hz | 25 Hz | 25 Hz | 25 Hz | 25 Hz |

| TYPE | U.S.A. | EUROPE | U.K. | SWEDEN | SWISS | AUSTRIA |
|----------------|--------|--------|------|--------|-------|---------|
| #3 | | | | | | |
| NUMERIC | | | | | | |
| Param | | | | | | |
| 01: | 0 | 0 | 0 | 0 | 0 | 0 |
| 02: | 10 | 10 | 10 | 10 | 10 | 10 |
| 03: | 15 | 15 | 15 | 15 | 15 | 15 |
| 04: | 12 | 12 | 12 | 12 | 12 | 12 |
| 05: | 4 | 4 | 4 | 4 | 4 | 4 |
| 06: | 4 | 4 | 1 | 4 | 4 | 4 |
| 07: | 350 | 350 | 350 | 350 | 350 | 350 |
| 08: | 0 | 0 | 0 | 0 | 0 | 0 |
| 09: | 6 | 6 | 6 | 6 | 6 | 6 |
| 10: | 5500 | 5500 | 5500 | 5500 | 5500 | 5500 |
| 11: | 3500 | 3500 | 3500 | 3500 | 3500 | 3500 |
| 12: | 0 | 0 | 0 | 0 | 0 | 0 |
| 13: | 1300 | 1300 | 1300 | 1300 | 1300 | 1300 |
| 14: | 0 | 0 | 0 | 0 | 0 | 0 |
| 15: | 120 | 120 | 120 | 120 | 120 | 120 |
| 16: | 4 | 2 | 2 | 2 | 2 | 2 |
| 17: | 100 | 100 | 100 | 100 | 100 | 100 |
| 18: | 0 | 0 | 0 | 0 | 0 | 0 |
| 19: | 200 | 400 | 400 | 400 | 400 | 400 |
| 20: | 100 | 100 | 100 | 100 | 100 | 100 |
| 21: | 0 | 0 | 0 | 0 | 0 | 0 |
| 22: | 200 | 400 | 400 | 400 | 400 | 400 |
| 23: | 44 | 44 | 44 | 44 | 44 | 44 |
| 24: | 20 | 10 | 10 | 10 | 10 | 10 |
| 25: | 60 | 60 | 60 | 60 | 60 | 60 |
| 26: | 44 | 44 | 44 | 44 | 44 | 44 |
| 27: | 0 | 0 | 0 | 0 | 0 | 0 |

| TYPE | DENMARK | NORWAY | HOLLAND | BELGIUM | AUSTRALIA | FINLAND |
|----------------|---------|--------|---------|---------|-----------|---------|
| #3 | | | | | | |
| NUMERIC | | | | | | |
| Param | | | | | | |
| 01: | 0 | 0 | 0 | 0 | 0 | 0 |
| 02: | 10 | 10 | 10 | 10 | 10 | 10 |
| 03: | 15 | 15 | 15 | 15 | 15 | 15 |
| 04: | 12 | 12 | 12 | 12 | 12 | 12 |
| 05: | 4 | 4 | 4 | 4 | 4 | 4 |
| 06: | 4 | 4 | 4 | 4 | 4 | 4 |
| 07: | 350 | 350 | 350 | 350 | 350 | 350 |
| 08: | 0 | 0 | 0 | 0 | 0 | 0 |
| 09: | 6 | 6 | 6 | 6 | 6 | 6 |
| 10: | 5500 | 5500 | 5500 | 5500 | 5500 | 5500 |
| 11: | 3500 | 3500 | 3500 | 3500 | 3500 | 3500 |
| 12: | 0 | 0 | 0 | 0 | 0 | 0 |
| 13: | 1300 | 1300 | 1300 | 1300 | 1300 | 1300 |
| 14: | 0 | 0 | 0 | 0 | 0 | 0 |
| 15: | 120 | 120 | 120 | 120 | 120 | 120 |
| 16: | 2 | 2 | 2 | 2 | 2 | 2 |
| 17: | 100 | 100 | 100 | 100 | 100 | 100 |
| 18: | 0 | 0 | 0 | 0 | 0 | 0 |
| 19: | 400 | 400 | 400 | 400 | 400 | 400 |
| 20: | 100 | 100 | 100 | 100 | 100 | 100 |
| 21: | 0 | 0 | 0 | 0 | 0 | 0 |
| 22: | 400 | 400 | 400 | 400 | 400 | 400 |
| 23: | 44 | 44 | 44 | 44 | 44 | 44 |
| 24: | 10 | 10 | 10 | 10 | 10 | 12 |
| 25: | 60 | 60 | 60 | 60 | 60 | 60 |
| 26: | 44 | 44 | 44 | 44 | 44 | 44 |
| 27: | 0 | 0 | 0 | 0 | 0 | 0 |

| TYPE | N.Z | ITALY | SPAIN | PORTUGAL | IRELAND | HONG KONG |
|----------------|------|-------|-------|----------|---------|-----------|
| #3 | | | | | | |
| NUMERIC | | | | | | |
| Param | | | | | | |
| 01: | 0 | 0 | 0 | 0 | 0 | 0 |
| 02: | 10 | 10 | 10 | 10 | 10 | 10 |
| 03: | 15 | 15 | 15 | 15 | 15 | 15 |
| 04: | 12 | 12 | 12 | 12 | 12 | 12 |
| 05: | 4 | 4 | 15 | 4 | 4 | 4 |
| 06: | 4 | 4 | 3 | 4 | 4 | 1 |
| 07: | 350 | 350 | 350 | 350 | 350 | 350 |
| 08: | 0 | 0 | 0 | 0 | 0 | 0 |
| 09: | 6 | 6 | 6 | 6 | 6 | 6 |
| 10: | 5500 | 5500 | 5500 | 5500 | 5500 | 5500 |
| 11: | 3500 | 3500 | 3500 | 3500 | 3500 | 3500 |
| 12: | 0 | 0 | 0 | 0 | 0 | 0 |
| 13: | 1300 | 1300 | 1300 | 1300 | 1300 | 1300 |
| 14: | 0 | 0 | 0 | 0 | 0 | 0 |
| 15: | 120 | 120 | 120 | 120 | 120 | 120 |
| 16: | 2 | 2 | 2 | 2 | 2 | 2 |
| 17: | 100 | 100 | 100 | 100 | 100 | 100 |
| 18: | 0 | 0 | 0 | 0 | 0 | 0 |
| 19: | 400 | 400 | 400 | 400 | 400 | 400 |
| 20: | 100 | 100 | 100 | 100 | 100 | 100 |
| 21: | 0 | 0 | 0 | 0 | 0 | 0 |
| 22: | 400 | 400 | 400 | 400 | 400 | 400 |
| 23: | 44 | 44 | 44 | 44 | 44 | 44 |
| 24: | 10 | 10 | 10 | 10 | 10 | 10 |
| 25: | 60 | 60 | 60 | 60 | 60 | 60 |
| 26: | 44 | 44 | 44 | 44 | 44 | 44 |
| 27: | 0 | 0 | 0 | 0 | 0 | 0 |

| TYPE | MALAYSIA | HUNGARY | SAF | KOREA | CHINA | GERMAN |
|----------------|----------|---------|------|-------|-------|--------|
| #3 | | | | | | |
| NUMERIC | | | | | | |
| Param | | | | | | |
| 01: | 0 | 0 | 0 | 0 | 0 | 0 |
| 02: | 10 | 10 | 10 | 10 | 10 | 8 |
| 03: | 15 | 15 | 15 | 15 | 15 | 15 |
| 04: | 12 | 12 | 12 | 12 | 12 | 6 |
| 05: | 4 | 4 | 4 | 4 | 4 | 4 |
| 06: | 4 | 4 | 4 | 4 | 4 | 4 |
| 07: | 350 | 350 | 350 | 350 | 350 | 350 |
| 08: | 0 | 0 | 0 | 0 | 0 | 0 |
| 09: | 6 | 6 | 6 | 6 | 6 | 6 |
| 10: | 5500 | 5500 | 5500 | 5500 | 4300 | 9000 |
| 11: | 3500 | 3500 | 3500 | 3500 | 3500 | 3500 |
| 12: | 0 | 0 | 0 | 0 | 0 | 0 |
| 13: | 1300 | 1300 | 1300 | 1300 | 1200 | 1300 |
| 14: | 0 | 0 | 0 | 0 | 0 | 0 |
| 15: | 120 | 120 | 120 | 120 | 120 | 120 |
| 16: | 2 | 2 | 2 | 2 | 2 | 2 |
| 17: | 100 | 100 | 100 | 100 | 100 | 100 |
| 18: | 0 | 0 | 0 | 0 | 0 | 0 |
| 19: | 400 | 400 | 400 | 400 | 400 | 400 |
| 20: | 100 | 100 | 100 | 100 | 100 | 100 |
| 21: | 0 | 0 | 0 | 0 | 0 | 0 |
| 22: | 400 | 400 | 400 | 400 | 400 | 400 |
| 23: | 44 | 44 | 44 | 44 | 44 | 44 |
| 24: | 10 | 10 | 10 | 10 | 10 | 10 |
| 25: | 60 | 60 | 60 | 60 | 60 | 60 |
| 26: | 44 | 44 | 44 | 44 | 44 | 44 |
| 27: | 0 | 0 | 0 | 0 | 0 | 0 |

| TYPE | FRANCE | SINGAPORE | CZECH | SLOVENIA | CANADA | J APAN |
|----------------|--------|-----------|-------|----------|--------|--------|
| #3 | | | | | | |
| NUMERIC | | | | | | |
| Param | | | | | | |
| 01: | 0 | 0 | 0 | 0 | 0 | 0 |
| 02: | 8 | 10 | 10 | 10 | 10 | 10 |
| 03: | 15 | 15 | 15 | 15 | 15 | 15 |
| 04: | 12 | 12 | 12 | 12 | 12 | 12 |
| 05: | 4 | 4 | 4 | 4 | 4 | 4 |
| 06: | 4 | 4 | 4 | 4 | 4 | 4 |
| 07: | 350 | 350 | 350 | 350 | 350 | 350 |
| 08: | 0 | 0 | 0 | 0 | 0 | 0 |
| 09: | 6 | 6 | 6 | 6 | 6 | 6 |
| 10: | 5500 | 5500 | 5500 | 5500 | 5500 | 5500 |
| 11: | 3800 | 3500 | 3500 | 3500 | 3500 | 3500 |
| 12: | 0 | 0 | 0 | 0 | 0 | 0 |
| 13: | 1300 | 1300 | 1300 | 1300 | 1300 | 1300 |
| 14: | 0 | 0 | 0 | 0 | 0 | 0 |
| 15: | 120 | 120 | 120 | 120 | 120 | 120 |
| 16: | 2 | 2 | 2 | 2 | 4 | 4 |
| 17: | 100 | 100 | 100 | 100 | 100 | 100 |
| 18: | 0 | 0 | 0 | 0 | 0 | 0 |
| 19: | 400 | 400 | 400 | 400 | 200 | 200 |
| 20: | 100 | 100 | 100 | 100 | 100 | 100 |
| 21: | 0 | 0 | 0 | 0 | 0 | 0 |
| 22: | 400 | 400 | 400 | 400 | 200 | 200 |
| 23: | 44 | 44 | 44 | 44 | 44 | 44 |
| 24: | 10 | 10 | 10 | 10 | 20 | 15 |
| 25: | 60 | 60 | 60 | 60 | 60 | 60 |
| 26: | 44 | 44 | 44 | 44 | 44 | 44 |
| 27: | 0 | 0 | 0 | 0 | 0 | 0 |

| TYPE | RUSSIA | ASIA | POLAND | EUROPE2 | STANDARD |
|----------------|--------|------|--------|---------|----------|
| #3 | | | | | |
| NUMERIC | | | | | |
| Param | | | | | |
| 01: | 0 | 0 | 0 | 0 | 0 |
| 02: | 10 | 10 | 10 | 10 | 10 |
| 03: | 15 | 15 | 15 | 15 | 15 |
| 04: | 12 | 12 | 12 | 12 | 12 |
| 05: | 4 | 4 | 4 | 4 | 4 |
| 06: | 4 | 4 | 4 | 4 | 4 |
| 07: | 350 | 350 | 350 | 350 | 350 |
| 08: | 0 | 0 | 0 | 0 | 0 |
| 09: | 6 | 6 | 6 | 6 | 6 |
| 10: | 5500 | 5500 | 5500 | 5500 | 5500 |
| 11: | 3500 | 3500 | 3500 | 3500 | 3500 |
| 12: | 0 | 0 | 0 | 0 | 0 |
| 13: | 1300 | 1300 | 1300 | 1300 | 1300 |
| 14: | 0 | 0 | 0 | 0 | 0 |
| 15: | 120 | 120 | 120 | 120 | 120 |
| 16: | 2 | 2 | 2 | 2 | 2 |
| 17: | 100 | 100 | 100 | 100 | 100 |
| 18: | 0 | 0 | 0 | 0 | 0 |
| 19: | 400 | 400 | 400 | 400 | 400 |
| 20: | 100 | 100 | 100 | 100 | 100 |
| 21: | 0 | 0 | 0 | 0 | 0 |
| 22: | 400 | 400 | 400 | 400 | 400 |
| 23: | 44 | 44 | 44 | 44 | 44 |
| 24: | 10 | 10 | 10 | 10 | 10 |
| 25: | 60 | 60 | 60 | 60 | 60 |
| 26: | 44 | 44 | 44 | 44 | 44 |
| 27: | 0 | 0 | 0 | 0 | 0 |

3-6 Test Mode / Factory Mode

This machine is equipped with the test mode to check operations of various functions listed below. To enter into the test mode, select TEST MODE in the menu items of the service data and press the OK button.

To enter into the FACTORY MODE, press the Menu button after entering into the TEST MODE.

To end the TEST MODE and the FACTORY MODE, press the Stop/Reset button. Then turn the power OFF/ON with the power button.

3-6-1 Test Mode/FACTORY Mode Overview

Test mode and FACTORY Mode can be executed by following the menu items from the display.

a) PRINT EEPROM (Test mode)

Can confirm EEPROM information in the printer. Select [3] PRINTER - [4] EEPROM from the test mode menu, and press the OK button. For the details, please refer to [3-8 Confirmation/3-8-6 EEPROM information print] .

b) CD-R calibration (Test mode)

Compensates for label recognition in printing a CD-R label.

c) PANEL (FACTORY MODE)

Tests the functions of operation panel.

d) PRINTER SHUKKEN (FACTORY MODE)

Prints test patterns within the print area.

e) IRDA Test (FACTORY MODE)

Tests the functions of IRDA test.

3-6-2 Test mode menu

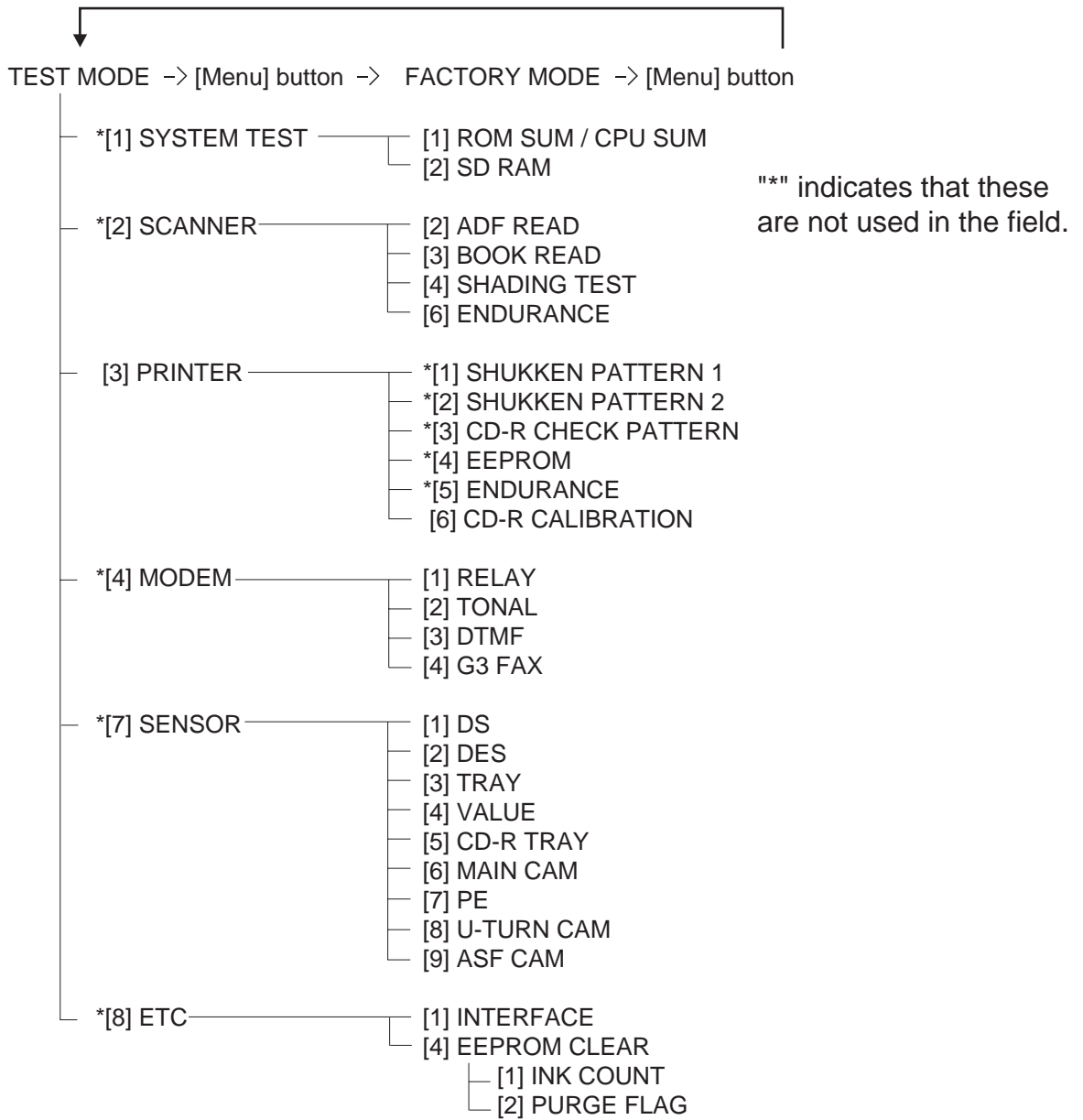

Figure 1-32 Test Mode

3-6-3 Factory mode menu

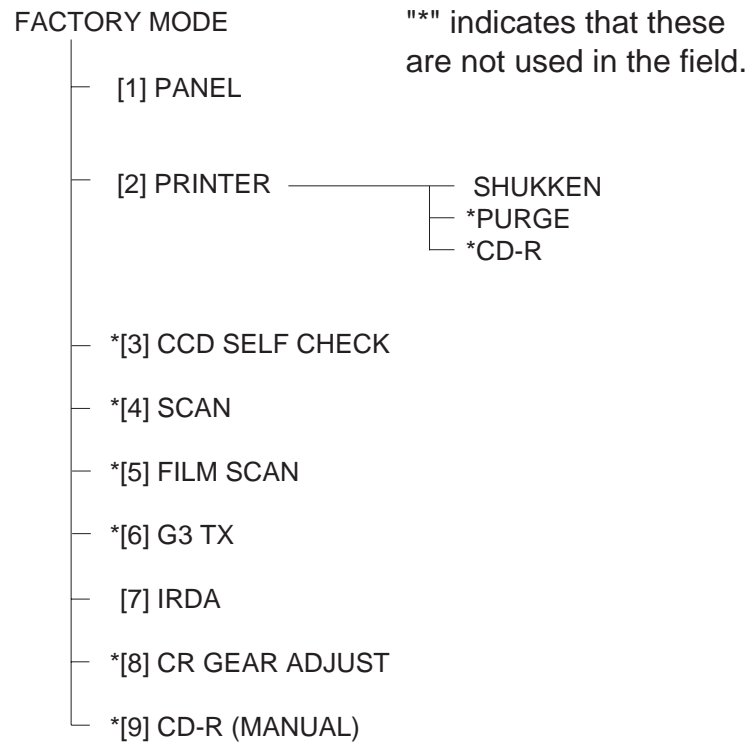

Figure 1-33 Factory Mode

3-6-4 Operation Panel Tests

If you select test menu in the FACTORY mode, [1] PANE is displayed. To select the test menu, press the OK button. In this test, check that the display, LED lamps, and keys on the control panel are operating correctly.

(a) Display test

When the Color Start key is pressed from the Panel menu, patterns in black or in color appear in LCD Viewer. Check whether each patterns is displayed correctly in the LCD Viewer.

(b) LED lamp test

The LED lamp test is selected by pressing the Color Start key after the display test.

When the Color Start key is pressed, all the lamps on the control panel light. Check for any LED that does not light during the test.

(c) Operation key test

The Operation key test is selected by pressing the Color Start key after the LED lamp test.

In this test, you press the key corresponding to the displayed character to put it out. The table giving the correspondence between the characters and the keys is below.

Character Operation key Character Operation key

| | | | |
|---|-------------------|---|--------------|
| C | COPY button | W | ON/OFF |
| S | SCAN button | E | Search |
| I | FILM button | G | Trimming |
| P | PHOTO button | N | under |
| 2 | Two-Sided button | R | Right |
| M | Menu | K | OK button |
| T | Settings | L | Left button |
| U | Upper button | C | Color button |
| S | Stop/Reset button | M | Black button |

3-6-5 PRINT TEST

Select SHUKKEN of the PRINTER test from the FACTORY MODE menu to print out the print pattern.

The following items can be checked in the print pattern.

< EEPROM information contents >

On the service test print (sample below), confirm the EEPROM information as shown below. (The information is given in the upper portion of the printout.)

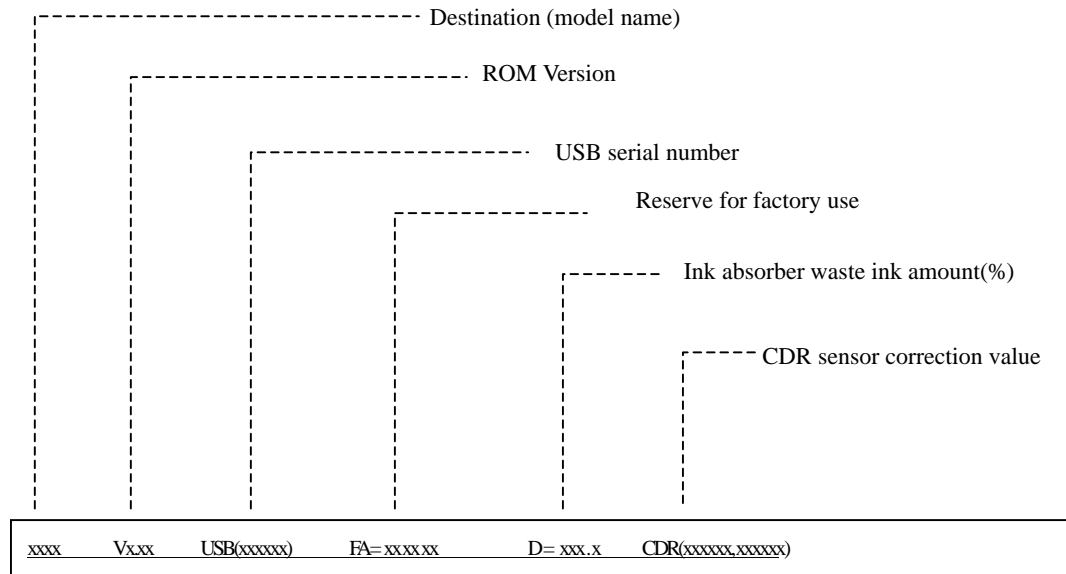

< Print check items >

On the service test print (sample below), confirm the following items:

Check 1 noz z le check pattern: Ink shall be ejected from all noz z les

Check 2 top of form accuracy: The line shall not extend off the paper.

Check 3 vertical straight lines: The line shall not be broken.

Check 4 halftone: There shall be no remarkable streaks or unevenness.

< Service test print sample >

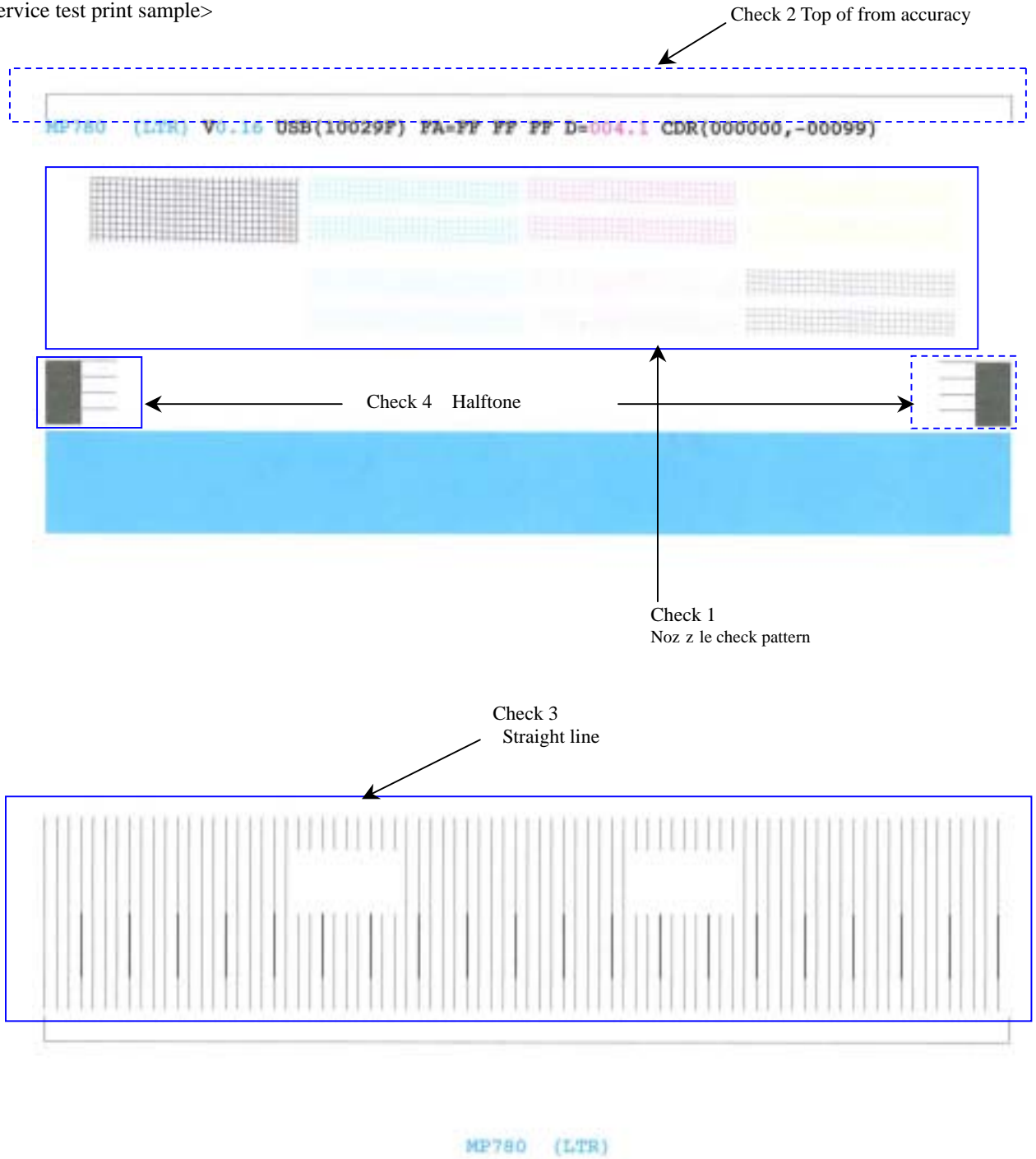

Figure 1-34 Service test print

3-6-6 CD-R Calibration

When SPCNT board ass'y, CD-R tray, or a unit or a part of printer (such as Carriage unit, Pump unit) is replaced, perform the CD-R calibration as follows (registration of CDR sensor compensation value data).

1. Place A4 plain paper on the Auto Sheet Feeder.
2. From the TEST MODE menu, perform [3] PRINTER - [6] CD-R CALIBRATION to print out a blank paper.
3. From the TEST MODE menu, perform [3] PRINTER[4] EEPROM to print out the information and check the CDRS (XXX) item. If a numeric value appears, it means OK. If (000) appears, it means NG. (Refer to 3-7-7 EEPROM Information Print.)

If it is NG, repeat the procedure of 1. to 3. shown above, or replace the unit.

3-6-7 IRDA TEST

Press the Menu button and select the FACTORY Test from the Test Mode menu.

From the FACTORY Test mode, press the right cursor button or the left cursor button to select [7] IRDA. In this test, it is confirmed whether an infrared data communication from a cellular phone is performed correctly. Perform the infrared data communication and check that "TEST OK" is displayed on LCD. Data received in this test is not output.

3-7 Upgrading the version of SPCNT flash ROM

To upgrade the version of flash ROM, always download via USB interface.

< Flash ROM upgrading file >

The flash ROM upgrading file will be distributed in SSIS at the timing of upgrading the version.

< Upgrading Procedure >

The detailed upgrading procedure will be introduced by a Service Information bulletin when the version is upgraded.

[Prerequisite (reference)]

- Printer to Personal Computer:

Connect via USB cable. (Connect only one printer to the computer.)

- Environment to be used, OS:

Windows 2000/XP

- Printer driver:

Should be installed in advance.

- Main Unit Mode when down loading the upgrading file:

Set " 1" at [# 1 SSSW] -[SW29] -[Bit 1] of the service data for the flash ROM upgrading mode.

3-8 Verification Items

3-8-1 EEPROM information print

< How to read EEPROM information print >

[Print sample]

MP770 V0.20 IF(USB1= 1 1284= 0) D= 004.5 ST= 2012/12/12-00:30
ER(ER0= 1612 ER1= 1602) LPT= 2012/12/13-02:16
PC(M= 000 R= 000 T= 003 D= 004 C= 002)
CLT(BK= 2012/12/13-02:22 CL= 2012/12/13-02:22)
CH= 00001 CT(BK1= 040 BK2= 000 C= 109 M= 012 Y= 113) IS(BK1= 0 BK2= 2 C= 0 M= 2 Y= 0
P_ON(S= 00014) A_REG= 1 M_REG= 0
UR(A(BKoe)= 000 B(Coe)= 000 C(Moe)= 000 D(SCoe)= 000 E(SMoe)= 000 F(PBKoe)= 000
G(BKbi)= + 02 H(CLbi)= 000 I(BK-CL)= -01 J (SCLbi)= 000 K(C-SC)= 000 L(M-SM)= 000)

WP= 0117 CDIN(LG= 000 PB= 000) MSD(000)
PAGE(All= 00075 PP= 00075 HR+ MP= 00000 PR+ SP+ SG= 00000 GP= 00000 PC= 00000 EV= 00000)
UCPAGE(All= 00051 PP= 00051 HR+ MP= 00000 PR+ SP+ SG= 00000 GP= 00000 PC= 00000
EV= 00000)
BPPAGE(All= 00107 BSGP= 00000 PC= 00000)
CDPAGE(All= 00000) EDGE= 00000 L= 00000 CDR= 00000
CDRP= (-00144,+ 00295) CDRS= (028)
Head TempBK= 36.0 Head TempC= 32.0 Env Temp= 30.0 FF(FF FF FF)

HDEEPROM
V0001
SN= 0318-A43D
LN(00000 00000 00001 00003 00001 00000 00000)
ID= 04
IL= (BK= 000 C= + 01 M= 000 Y= 000 C2= 000 M2= 000 PBK= 000)

Printed items:

1. Model name
2. ROM version
3. Connected I/F (USB1/1284)
4. Waste ink amount
5. Installation date
6. Operator call/service call error record
7. Last printing time
8. Purging count (manual/deep cleaning/timer/dot count/ink tank or print head replacement)
9. Cleaning time (BK/CL)
10. Print head replacement count
11. Ink tank replacement count (pigment BK/dye BK/C/M/Y)
12. Ink status (pigment BK/dye BK/C/M/Y)
13. Power-on count (soft)
14. Automatic print head alignment by user
15. Manual print head alignment by user
16. User print head alignment values
(Bkoe/Coe/Moe/SCoe/SMoe/PBKoe/BKbi/CLbi/BK-PCBK/SCLbi/C-SC/M-SM)
17. Wiping count
18. Camera Direct Print-supported device connection record
19. Longest period where printing stops
20. ASF feed pages (total, plain paper, High Resolution Paper & Matte Photo Paper, Photo Paper Pro & Photo Paper Plus Glossy & Photo Paper Plus Semi-gloss, Glossy Photo Paper, Postcard, Envelope)
21. U-turn cassette feed pages (total, plain paper, High Resolution Paper & Matte Photo Paper, Photo Paper Pro & Photo Paper Plus Glossy & Photo Paper Plus Semi-gloss, Glossy Photo Paper, postcard, envelope)

- 22. Auto duplex print pages (total, Photo Paper Plus Double Sided, postcard)
- 23. Camera Direct print pages (total) 24. Borderless print pages 25. L & 4x6 print pages
- 26. Number of CD-Rs printed
- 27. CD-R print position adjustment 28. CD-R sensor correction value
- 29. Print head temperature (BK/CL) 30. Inside temperature 31. Line inspection information

HDEEPROM

- 32. Version
- 33. Serial number
- 34. Lot number
- 35. Print head ID
- 36. Ink ejection level (BK/C/M/Y/C2/M2/PBK)

4. Cleaning Your Machine

This section describes the necessary cleaning procedures for your machine.

4-1 CAUTION

- Be sure to turn OFF the power and disconnect the power cord before cleaning the machine.
- If you turn OFF the machine, all the documents stored in memory are deleted. Print all the necessary documents stored in memory before turning OFF the machine.
- Do not use tissue paper, paper towels, or similar materials for cleaning; they can stick to the components or generate static charges. Use a soft cloth to avoid scratching the components.
- Never use volatile liquids such as thinners, benzene, acetone, or any other chemical cleaner to clean the machine; these can damage the machine's components.

4-2 Cleaning The Exterior

Wipe the machine's exterior with a clean, soft, lint-free damp cloth.

4-3 Cleaning the Scan area

Wipe the Platen Glass (A) and the inner side of the Document Cover (white area) (B) with a clean, soft, lint-free cloth moistened with water. Then wipe with a clean, soft, dry, lint-free cloth making sure not to leave any residue, especially on the Platen Glass. If you have trouble getting the scanning area clean, wipe with diluted mild detergent (for dish washing).

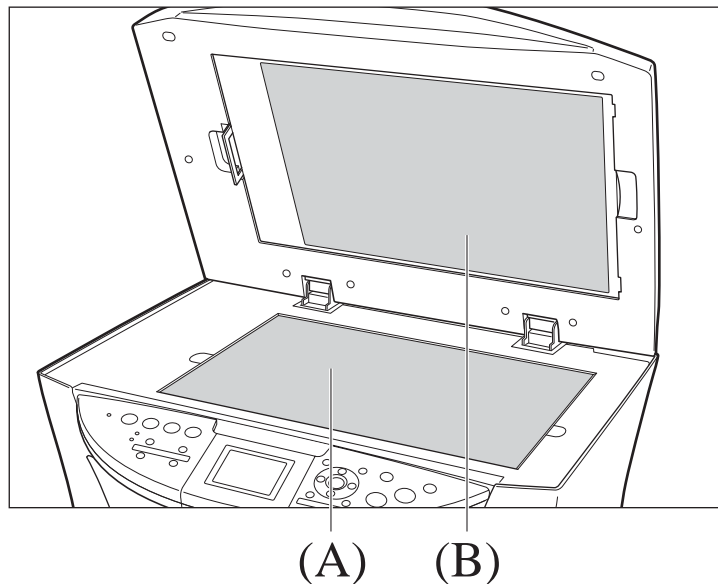

Figure 1-35 Cleaning the Scan area

4-4. Cleaning The Interior

Regularly clean the interior of the machine to avoid deterioration in print quality due to parts being dirtied by ink or paper dust.

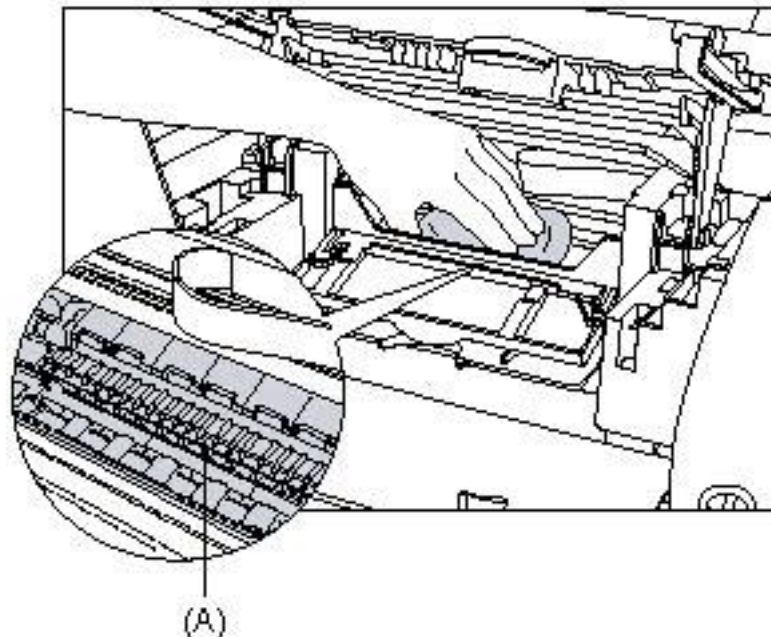

Figure 1-36 Cleaning The Interior

4-5 Cleaning the paper feed roller

Follow this procedure:

1. Connect the power cord, and power on the machine.
2. Remove any paper from the Auto Sheet Feeder and Cassette.
3. Select the paper source with [Feed Switch] .
4. Press [Menu] repeatedly until < Maintenance Settings> appears, then press [OK] twice.
5. Use [Right cursor] or [Left cursor] to select < Roller Cleaning> .
6. Press [OK] .

The machine starts cleaning the roller.

7. When cleaning has finished, repeat steps 3 to 6 for a total of two times.
8. Load A4- or letter-size plain paper in the Auto Sheet Feeder or Cassette and repeat steps 3 to 5 an additional three times.

4-6 Cleaning The Bottom Plate

Follow this procedure:

1. Power on then connect the power cord.
2. Remove any paper from the Auto Sheet Feeder.
3. Prepare a sheet of A4 or Letter size plain paper. Fold it in half along the long edge. Unfold the paper, then load it in the paper support with the outside edge of the fold facing down.
4. Press [Menu] repeatedly until < Maintenance Settings > appears, then press [OK] twice.
5. Use [Right cursor] or [Left cursor] to select < Bottom Cleaning > .
6. Press [OK] .

The paper is fed and output.

MEMO:

If this component is still dirty after performing the operation described above, use a clean cotton bud to remove ink stain, paper powder, and dust around the platen (A).

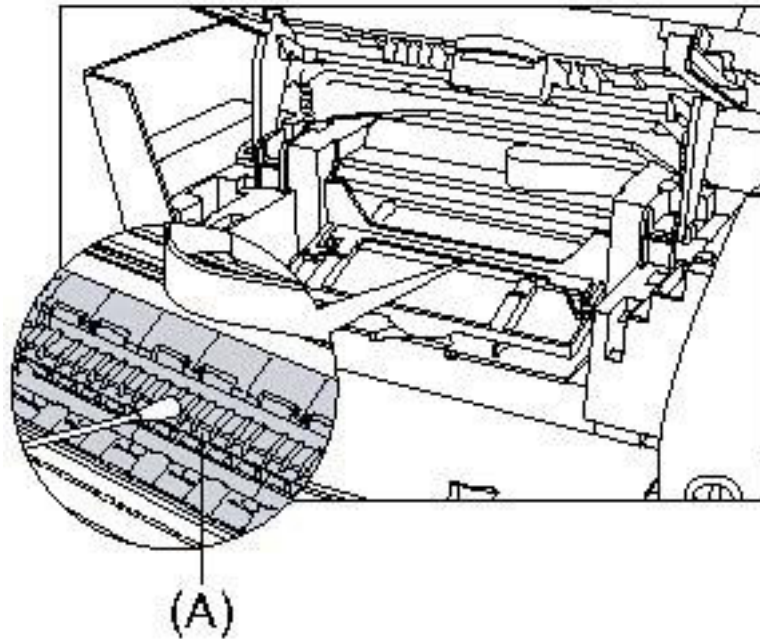

Figure 1-37 Cleaning the Platen

5. TRANSPORTATION

This section describes the procedures for transporting the printer for returning after repair, etc.

- (1) Keep the print head and ink tanks installed in the carriage. [See NOTE (1) on the next page.]
- (2) Turn off the printer to securely lock the carriage in the home position. (When the printer is turned off, the carriage is automatically locked in place.) [See NOTE (2) on the next page.]
- (3) To further secure the carriage to prevent movement from the home position during transportation, make and use a fixing tool in the following procedures:
 - (a). Fold an A4-sized paper 5 times, and wrap it twice with tape, as shown in Figure A below (to prevent the fixing tool from caught into the inside of the printer).
 - (b). Insert the fixing tool between the carriage and the middle flame unit, and securely fix it with tape, as shown in Figures B and C below.

Note: The tape should be similar to the polyester tape used at shipment, which will not easily be torn or removed, or leave adhesive on the unit when removed.

Leave a sufficient length of tape to fix the tool so that the tape end is easily seen even when the access cover is closed, so that the user will remove the tool from the returned printer without fail.

Description of a small piece of paper (example):

Before the machine is powered on, remove this tape and the stuff at the end of the tape (the fixing tool on the cartridge).

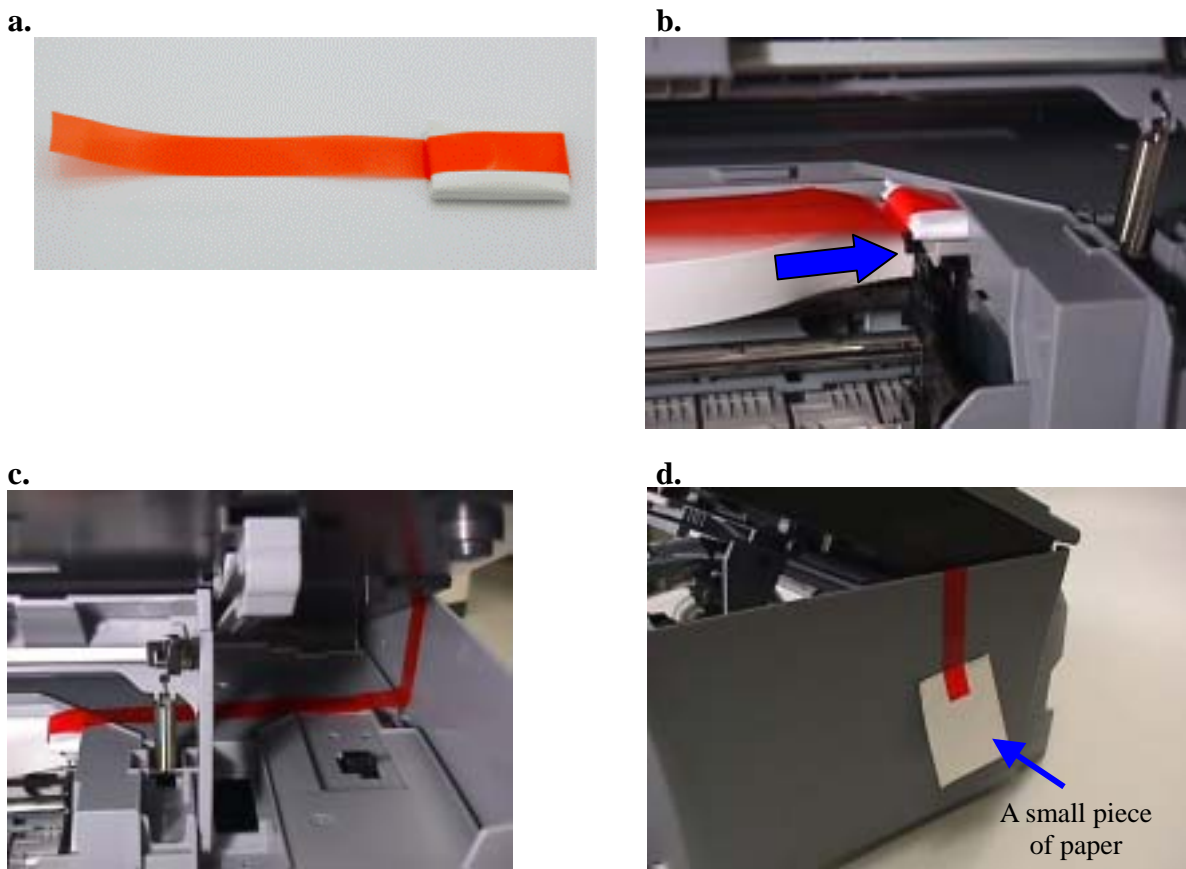

Figure 1-38 How to fix the Carriage

Caution:

- (1) If the print head is removed from the printer and left alone by itself, ink (especially the pigment black ink) is likely to dry. For this reason, keep the print head installed in the printer even during transportation.
- (2) Securely lock the carriage in the home position, to prevent the carriage from moving and applying stress to the carriage flexible cable, or causing ink leakage, during transportation.

Part 2

Technical Reference

1. NEW TECHNOLOGIES

(1) Dye black ink adoption

In addition to the pigment black ink, dye black ink is adopted in this machine, so that special paper can be printed in black ink. (For printing plain paper, the pigment black ink is used.)

(2) Automatic Print Head Position Alignment

In this machine, the print head position can be aligned automatically by operating the buttons on the operation panel and operating from the driver utility.

This is the function to detect the reflection density at the print head position alignment sensor (the same sensor as the CD-R position detection sensor) and appropriately set the print head position alignment by scanning the print pattern shown below.

The followings are detected during the automatic print head position alignment. If an error is detected, <AUTO HEAD ALIGN ERROR> (LCD message) is displayed.

1) Detecting Paper Size

- Detecting Paper Width (an error is detected if the paper width is too short.)
- Detecting Paper Length (an error is detected if the length is shorter than A4/LTR.)

2) Detecting Print Failure due to no ink ejected

- Detecting Ink Ejecting Status (an error is detected if no ink is ejected.)

<Print Pattern for the Automatic Print Head Position Alignment>

Plain Paper A4/LTR

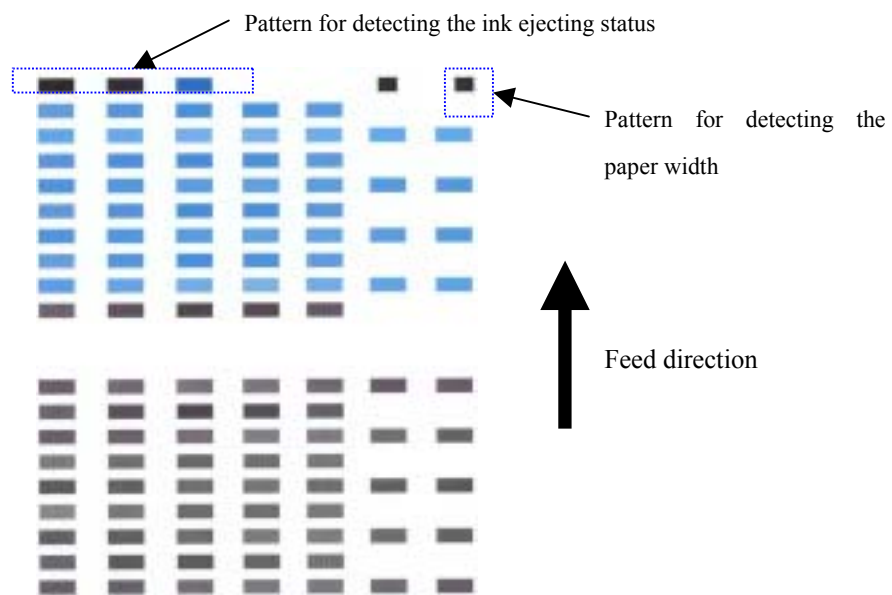

Figure 2-1 Print Pattern for the Automatic Print Head Position Alignment

<Phenomena of predictable troubles and the Solutions (how to avoid the troubles)>

- 1) Although the paper size is correct (A4/LTR) and the print head position alignment pattern is printed correctly, an error of the automatic print head position alignment failure occurs.

[Solution] Set “Align heads manually” to valid at the driver utility special settings, and perform the print head position alignment manually.

(3) Automatic duplex printing

This function can be used only when the paper size is set to <A4> or <LTR>.

<Phenomena of predictable troubles and the Solutions (how to avoid the troubles)>

- 1) The printing surface of paper is dirty. (Cause: Due to accumulated ink mist.)

The phenomena will be the following two types.

- a) A vertical line is printed incorrectly (stain on the platen rib).

[Solution] Clean the interior of the main unit.

- b) A horizontal stain is printed around 10 mm from the top edge of paper (back side) (stain in the interior of the double side unit).

[Solution] Replace the ASF unit.

(4) Making Multiple Copies of an Entire Document (Collation)

When making multiple copies of a document with more than one page, you have them delivered in sorted sets.

(Example): To copy three sets of a 3-page document (Page a, b, c in order) with the electronic sort.

The copied paper is delivered in order of (c, b, a), (c, b, a), (c, b, a).

2. CLEANING MODE AND AMOUNT OF INK PURGED

To prevent printing problems due to bubbles, dust, or ink clogging, print head cleaning is performed before the start of printing, except in the following cases:

- Cleaning on arrival: Performed when the access cover is closed.
- Cleaning by dot count: Performed after ejection of paper (or after printing on the back side of paper when auto duplex printing is performed).
- Manual cleaning / deep cleaning: Performed manually.

<Cleaning mode list>

*Black: Pigment-based black Color: Dye-based black, cyan, magenta, yellow

| Condition | Details | Amount of ink used(g) | Est. required time (sec) |
|--|---|-------------------------|--|
| On arrival of the printer (All in sequence) | First and second cleaning after shipped from the plant. | 0.45(BK) 1.50(Color) | 70 |
| Dot count cleaning*1 (Black/Color) | When the specified number of dots are printed since the previous Black/Color cleaning. (Cyan and magenta dots are counted by large and small nozzles separately.) | 0.14(BK) 0.50(Color) | 30(BK) 35(Color) |
| Timer cleaning - 0*2 (Black only) | If 24 to 60 hours have elapsed since the previous Black cleaning till the start of the next printing. | 0.14(BK) | 30(BK) |
| Timer cleaning - 1 (Black only) | If 60 to 96 hours have elapsed since the previous Black cleaning till the start of the next printing. | 0.14(BK) | 30(BK) |
| Timer cleaning - 2 (Black only) | If 96 to 120 hours have elapsed since the previous Black cleaning till the start of the next printing. | 0.14(BK) | 30(BK) |
| Timer cleaning - 3*3 (Black/Color) | If 120 to 336 hours have elapsed since the previous Black/Color cleaning till the start of the next printing | 0.14(BK) 0.50(color) | 30(BK) 35(color) |
| Timer cleaning - 4 (All in sequence) | If 336 to 504 hours have elapsed since the previous Black/Color cleaning till the start of the next printing | 0.45(BK) 1.00(Color) | 60 |
| Timer cleaning - 5 (All in sequence) | If 504 to 720 hours have elapsed since the previous Black/Color cleaning till the start of the next printing | 0.45(BK) 1.00(Color) | 60 |
| Timer cleaning - 6 (All in sequence) | If 720 to 1080 hours have elapsed since the previous Black/Color cleaning till the start of the next printing | 0.45(BK) 1.00(Color) | 60 |
| Timer cleaning - 7 (All in sequence) | If 1080 to 2160 hours have elapsed since the previous Black/Color cleaning till the start of the next printing | 0.78(BK) 1.00(Color) | 60 |
| Timer cleaning - 8 (All in sequence) | If 2160 to 4320 hours have elapsed since the previous Black/Color cleaning till the start of the next printing | 1.58(BK) 1.00(Color) | 65 |
| Timer cleaning - 9 (All in sequence) | If 4320 to 8640 hours have elapsed since the previous Black/Color cleaning till the start of the next printing | 1.58(BK) 1.00(Color) | 65 |
| Timer cleaning - 10 (All in sequence) | If 8,640 or longer hours have elapsed since the previous Black/Color cleaning till the start of the next printing | 1.58(BK) 1.00(Color) | 65 |
| At print head replacement (All in sequence) | When the print head is removed and installed. | 0.45(BK) 1.50(Color) | 70 |
| At ink tank replacement (Black/Color) | | 0.30(BK) 1.00(Color) | 45 (All in sequence) 30(BK) 35(color) |

| Condition | Details | Amount of ink used(g) | Est. required time (sec) |
|--|---|-------------------------|---|
| Manual cleaning (Black/Color/All at the sametime) | - Via the operation panel (All at the same time only) - Via the printer driver (Selectable from Black, Color, or All at the same time) | 0.14(BK) 0.50(Color) | 45 (All at the same time) 30(BK) 40(Color) |
| Deep cleaning (Black/Color/All at the same time) | Via the printer driver (Selectable from Black, Color, or All at the same time) | 1.58(BK) 1.00(Color) | 65 (All at the same time) 45(BK) 50(Color) |
| If the print head has not been capped before power-on (All in sequence) | | 0.30(BK) 1.00(Color) | 45 (All in sequence) |

*1: The dots since the previous cleaning are counted by Black and Color separately. For this reason, the cleaning mode may differ according to Black or Color.

*2: When 24 to 60 hours have elapsed since the previous Black cleaning, timer cleaning - 0 is performed. However, this cleaning will be conducted up to 5 times from the printer installation, and no further timer cleaning - 0 will be performed.

*3: The period of time since the previous cleaning is counted by Black and Color separately. For this reason, the cleaning mode may differ according to Black or Color.

3. Print Mode

(1) Copy

INK
(Column: Number
of Colors)

BK :BCI-3eBK
C :BCI-6C 5pl
M :BCI-6M 5pl
Y :BCI-6Y
k :BCI-6BK
c :BCI-6C 2pl
m :BCI-6M 2pl

("CMcm" shown in a column means printing in the mixture of CM5pl/cm2pl.)

| Print Quality | | 5 | 4 | 3 | 2 | 1 |
|---|-----------------|-----------------|---|---------------------|---------------------|---|
| PP | Mode | color draft | | color standard | color fine | |
| | Resolution(dpi) | 150x600 | - | 1200x1200dpi | 1200x1200dpi | - |
| | No. of passes | CMYBK 1 pass | | CMYBK 1 pass | CMYBKcm 4 passes | |
| PP Two-sided printing | Mode | color draft | | color standard | color fine | |
| | Resolution(dpi) | 150x600 | - | 1200x1200dpi | 1200x1200dpi | - |
| | No. of passes | CMYBK 1 pass | | CMYBK 1 pass | CMYBKcm 4 passes | |
| PP White/Bk | Mode | W/B draft | | W/B standard | W/B fine | |
| | Resolution(dpi) | 150x600 | - | 600x600dpi | 600x600dpi | - |
| | No. of passes | BK 1 pass | | CMYBK 1 pass | CMYBKcm 4 passes | |
| PP White/Bk Two-sided printing | Mode | W/B draft | | W/B standard | W/B fine | |
| | Resolution(dpi) | 150x600 | - | 1200x1200dpi | 1200x1200dpi | - |
| | No. of passes | CMYBK 1 pass | | CMYBK 1 pass | CMYBKcm 4 passes | |
| PR | Mode | | | color and W/B fine | filme copy | |
| | Resolution(dpi) | - | - | 1200x1200dpi | 1200x1200dpi | - |
| | No. of passes | | | CMYcmk 4 passes | CMYcmk 6 passes | |
| SP (GP/HR/IJ- PC/ other photo) | Mode | | | color and W/B fine | filme copy | |
| | Resolution(dpi) | - | - | 1200x1200dpi | 1200x1200dpi | - |
| | No. of passes | | | CMYcmk 4 passes | CMYcmk 6 passes | |
| OHP | Mode | | | color and W/B fine | | |
| | Resolution(dpi) | - | - | 1200x1200dpi | - | - |
| | No. of passes | | | CMYBKcm 4 passes | | |

(2) Standard Color Printing (at PC Printer Driver)

| | |
|--|------------------------|
| | Default setting |
| | Can be set at Main tab |
| | custom setting |

Ink tank 5 color : BCI-3eBK / 6BK / 6C / 6M / 6Y
 4 color *1 : BCI-3eBK / 6C / 6M / 6Y
 4 color *2 : BCI-6BK / 6C / 6M / 6Y
 3 color : BCI-6C / 6M / 6Y
 1 color : BCI-3eBK

| paper type | Drv. UI Custom | Fast 5 | <— 4 | 3 | —> 2 | High Quality 1 |
|---|---|---|---|---|--|--|
| Plain paper (PP) | Print Quality Resolution(dpi) Pass Print control Ink | Custom 600x600 1 pass 4 color*1 | Draft 600x600 1 pass 4 color*1 | Standard 1200x1200 1 pass 4 color*1 | High 1200x1200 4 pass 4 color*1 | |
| Photo Pater Pro (PR) PR-101 | Print Quality Resolution(dpi) Pass Print control Ink | | | Standard 1200x1200 4 pass 4 color*2 | High 1200x1200 6 pass 4 color*2 | Custom 4800x1200 16 pass 4 color*2 |
| Sper Photo Paper SP-101/SG-101 | Print Quality Resolution(dpi) Pass Print control Ink | | Draft 1200x1200 3 pass 4 color*2 | Standard 1200x1200 4 pass 4 color*2 | High 1200x1200 6 pass 4 color*2 | |
| Matte Photo Paper MP-101 | Print Quality Resolution(dpi) Pass Print control Ink | | | Standard 1200x1200 4 pass 4 color*2 | High 1200x1200 6 pass 4 color*2 | |
| Glossy Photo Paper GP-401 | Print Quality Resolution(dpi) Pass Print control Ink | | | Standard 1200x1200 4 pass 4 color*2 | High 1200x1200 6 pass 4 color*2 | |
| Super Photo Paper Double Side SP-101D | Print Quality Resolution(dpi) Pass Print control Ink | | | Standard 1200x1200 4 pass 4 color*2 | High 1200x1200 6 pass 4 color*2 | |
| High Resoluton Paper HR-101S | Print Quality Resolution(dpi) Pass Print control Ink | | | Standard 1200x1200 4 pass 4 color*2 | High 1200x1200 6 pass 4 color*2 | |
| Postal Card | Print Quality Resolution(dpi) Pass Print control Ink | | | Standard 1200x1200 2 pass 5 color | High 1200x1200 4 pass 5 color | |
| Postal Card for Inkjet printer | Print Quality Resolution(dpi) Pass Print control Ink | | Draft 1200x1200 2 pass-Bi- directional 4 color*2 | Standard 1200x1200 3 pass 4 color*2 | High 1200x1200 4 pass 4 color*2 | |
| Transparncy CF-102 | Print Quality Resolution(dpi) Pass Print control Ink | | | Standard 1200x1200 4 pass 5 color | High 1200x1200 6 pass 5 color | |
| T-Shirt Transfers TR-301 | Print Quality Resolution(dpi) Pass Print control Ink | | | High 1200x1200 6 pass 3 color | | |
| CD-R(Commend) 230V only | Print Quality Resolution(dpi) Pass Print control Ink | | | Draft 1200x1200 4 pass-Bi- directional 4 color*2 | Standard 1200x1200 6 pass-Bi- directional 4 color*2 | High 1200x1200 8 pass-Bi- directional 4 color*2 |
| CD-R(Other) 230V only | Print Quality Resolution(dpi) Pass Print control Ink | | | Draft 1200x1200 4 pass-Bi- directional 4 color*2 | Standard 1200x1200 6 pass-Bi- directional 4 color*2 | High 1200x1200 8 pass-Bi- directional 4 color*2 |
| Other Photo Paper | Print Quality Resolution(dpi) Pass Print control Ink | | | High 1200x1200 8 pass 4 color*2 | | |

(3) Standard Gray Scale Printing (at PC Printer Driver)

| Paper Type | Drv.UI | Fast 5 | <— 4 | 3 | —> 2 | High Quality 1 |
|-------------|---|---|--|---|---|-------------------|
| | Custom | | | | | |
| Plain Paper | Print Quality Resolution(dpi) Pass Print control Ink | Custom 300x300 1 pass 1 color | Draft 300x300 1 pass 1 color | Standard 600x600 1 pass 1 color | High 600x600 4 pass 1 color | |
| Postal Card | Print Quality Resolution(dpi) Pass Print control Ink | | | Standard 600x600 2 pass 1 color | High 600x600 4 pass 1 color | |

(4) Borderless Printing (at PC Printer Driver)

| Paper Type | Drv.UI | Fast 5 | <— 4 | 3 | —> 2 | High Quality 1 |
|---|---|-----------|--|--|---|--|
| | Custom | | | | | |
| Plain Paper | Print Quality Resolution(dpi) Pass Print control Ink | | | Standard 1200x1200 2 pass-Bi- directional 4 color*2 | | |
| Photo Paper Pro PR-101 | Print Quality Resolution(dpi) Pass Print control Ink | | | Standard 1200x1200 4 pass 4 color*2 | High 1200x1200 6 pass 4 color*2 | Custom 4800x1200 16 pass 4 color*2 |
| Super Photo Paper SP-101/SG-101 | Print Quality Resolution(dpi) Pass Print control Ink | | Draft 1200x1200 3 pass 4 color*2 | Standard 1200x1200 4 pass 4 color*2 | High 1200x1200 6 pass 4 color*2 | |
| Matte Photo Paper MP-101 | Print Quality Resolution(dpi) Pass Print control Ink | | | Standard 1200x1200 4 pass 4 color*2 | High 1200x1200 6 pass 4 color*2 | |
| Glossy Photo Paper GP-401 | Print Quality Resolution(dpi) Pass Print control Ink | | | Standard 1200x1200 4 pass 4 color*2 | High 1200x1200 6 pass 4 color*2 | |
| Super Photo Paper Double Side SP-101D | Print Quality Resolution(dpi) Pass Print control Ink | | | Standard 1200x1200 4 pass 4 color*2 | High 1200x1200 6 pass 4 color*2 | |
| Postal Card | Print Quality Resolution(dpi) Pass Print control Ink | | | Standard 1200x1200 2 pass 4 color*2 | High 1200x1200 4 pass 4 color*2 | |
| Postal Card for Inkjet printer | Print Quality Resolution(dpi) Pass Print control Ink | | Draft 1200x1200 2 pass 4 color*2 | Standard 1200x1200 3 pass 4 color*2 | High 1200x1200 4 pass 4 color*2 | |
| Other Photo Paper | Print Quality Resolution(dpi) Pass Print control Ink | | | High 1200x1200 8 pass 4 color*2 | | |

(5) Duplex Printing (at PC Printer Driver)

| Paper Type | Drv.UI Custom | Fast 5 | <— 4 | 3 | —> 2 | High Quality 1 |
|--|---|---|--|---|---|-------------------|
| Plain paper | Print Quality Resolution(dpi) Pass Print control Ink | Custom 600x600 1 pass 4 color*1 | Draft 600x600 1 pass 4 color*1 | Standard 1200x1200 1 pass 4 color*1 | High 1200x1200 4 pass 4 color*1 | |
| Super Photo Paper Double Side SP-101D | Print Quality Resolution(dpi) Pass Print control Ink | | | Standard 1200x1200 4 pass 4 color*2 | High 1200x1200 6 pass 4 color*2 | |
| Postal Card | Print Quality Resolution(dpi) Pass Print control Ink | | | Standard 1200x1200 2 pass 5 color | High 1200x1200 4 pass 5 color | |
| Postal Card for Inkjet printer *Supporting Duplex Printing only in using the Postal Card application | Print Quality Resolution(dpi) Pass Print control Ink | | Draft 1200x1200 2 pass 4 color*2 | Standard 1200x1200 4 pass 4 color*2 | High 1200x1200 6 pass 4 color*2 | |

(6) Camera Direct Printing (at PC Printer Driver)

| Paper type | Drv.UI Custom | Fast 5 | <— 4 | 3 | —> 2 | High Quality 1 |
|------------------------------------|---|-----------|---------|---|---|-------------------|
| Photo Paper Pro PR-101 | Print Quality Resolution(dpi) Pass Print control Ink | | | | High 1200x1200 6 pass 4 color*2 | |
| Super Photo Paper SP-101/SG-101 | Print Quality Resolution(dpi) Pass Print control Ink | | | | High 1200x1200 6 pass 4 color*2 | |

4. FAQ(Problems Specific to the MP760 and Corrective Actions)

| No | * | Function | Phenomenon | Condition | Cause | Corrective action | Possible call or complaint |
|----|---|------------------------------|--|--|--|--|---|
| 1 | C | Print results | Margin (approx. .3mm) | -Paper feeding from the cassette, Photo Paper Plus Double Sided (A4), orderless printing, printing on the back side of paper -In the low temperature and low humidity environment | | -In the printer driver, increase the amount of extension. -Change the paper feeding method from the cassette to the auto sheet feeder. | -A margin appears on printouts. -Paper feeds at an angle. |
| 2 | B | Print results | -Skewed paper feeding -Printing on the platen | -Plain paper -In the high temperature and high humidity environment | | -If paper is curled, straighten it. -Try printing on the other side of paper. | -Paper feeds at an angle. -Printing is performed on the platen. -The back side of paper gets smeared. |
| 3 | B | Print results | Variation in the top of form accuracy | -A5 or legal size -In the low temperature and low humidity environment -Not solved even when the number of sheets stacked in the auto sheet feeder or the cassette is reduced | Due to decrease of paper feed capability in the low temperature and low humidity environment | -Set the top margin to 4mm or more. | -Print start position varies. |
| 4 | B | Print results | -Skewed paper feeding -Margin | -Photo Paper Plus Double Sided -2L size (Japan only) | | -In the printer driver, increase the amount of extension. -Change the paper feeding method from the cassette to the auto sheet feeder. | -A margin appears on printouts. -Paper feeds at an angle. |
| 5 | C | Safety during transportation | Carriage lock lever dislocation | -With the print head and tanks installed -The phenomenon occurred in the freight handling test | | When returning the repaired printer to the user, insert the fixing tool(A4 plain paper folded 5 times) between the main case and the carriage, and fix it with tape. [See Part5. Transportation] | During transportation for return after repair, Ink dries, and no ink is ejected. |

| No | * | Function | Phenomenon | Condition | Cause | Corrective action | Possible call or complaint |
|----|---|---------------|--|--|--|---|--|
| 6 | A | Print results | Soiling on the back side of paper (lines or streaks parallel to the paper feed direction) | -After continuous borderless printing of small sized paper (such as 4x6), when a larger sized paper (such as A4) is rinted. -With Photo Paper Plus Double Sided or postcards, the phenomenon is likely to be noticeable and to be complained of by users, as printing is performed on both sides of such paper. | In borderless printing, printing is performed to the size slightly larger than the paper size, and ink off the paper is absorbed by the platen's ink absorber. Absorbed ink may attach to the platen rib(s) after several dozen sheets are printed, causing soiling at the leading edge of paper or on the back side of paper. | 1.Perform Bottom plate cleaning (from the printer driver) up to 3 times*1. *1: Change the paper in each Bottom plate cleaning. The cleaning can end when paper dose not get any soiling. 2.If soiling on the paper still remains after 3 times of Bottom plate cleaning, wipe the platen rib(s) and their surroundings with a cotton swab. | -Paper gets smeared. -The back side of paper gets smeared. |
| 7 | B | Print results | Soiling on paper in automatic duplex printing (lines or streaks perpendicular to the paper feed direction) | -Automatic duplex printing (Photo Paper Plus Double Sided, postcards, plain paper) | On the rib(s) inside the sheet feed unit used for duplex printing, ink mist may accumulate, smearing paper. | Cleaning by user: 1. Perform Bottom plate cleaning (from the printer driver) up to 3 times*1. *1: Change the paper in each Bottom plate cleaning. The cleaning can end when paper does not get any soiling. 2. If soiling on the paper still remains after 3times of Bottom plate cleaning, wipe the platen rib(s) and their surroundings with a cotton swab.If the phenomenon persists after conducting 1 and 2, servicing is required. Service: Wipe any soiling or dirt off from the sheet feed unit and the bottom case unit ribs*2. | cleaning was performed, and the platen ribs were cleaned with cotton swab, paper gets smeared. |

| No | * | Function | Phenomenon | Condition | Cause | Corrective action | Possible call or complaint |
|----|---|---------------|--------------------|---|---|--|--|
| 8 | C | Print results | Scratches on paper | -PP-101D, PP-101, PR-101, SG-101, etc. -Paper feeding from the cassette -Multiple number of sheets loaded | -Paper is scratched. -Marks appear on printed paper. | -Change the paper feeding method from the cassette to the auto sheet feeder. -If automatic duplex printing is performed, cancel it, and, by setting only a single sheet of paper in the auto sheet feeder, manually print each side of paper. | Scratches on the PF return lever due to paper feeding from the cassette, and duplex printing path. |

*2 Location to clean in servicing when soiling on paper in automatic duplex printing persists:

BOTTOM CASE UNIT

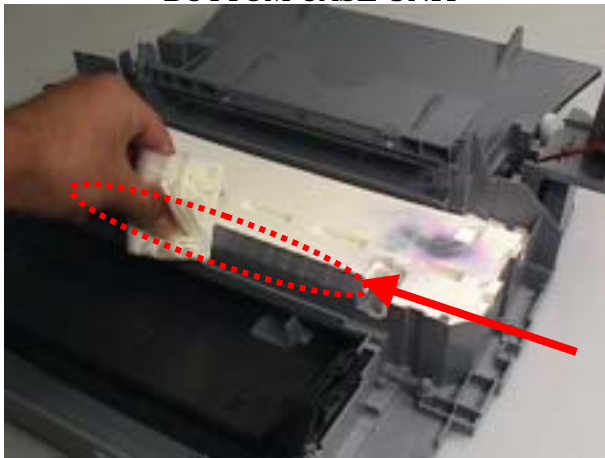

SHEET FEED UNIT

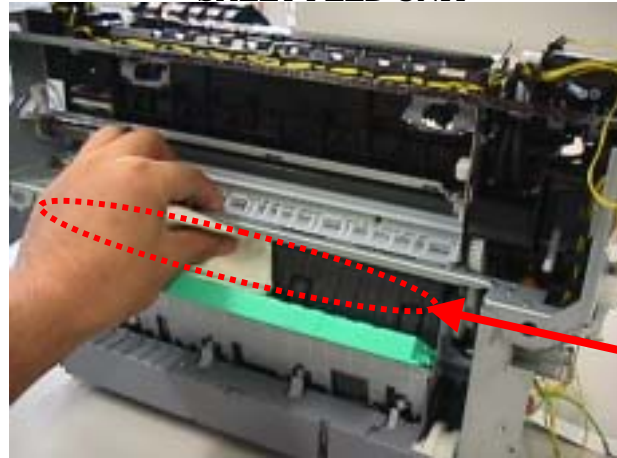

* Occurrence level:

A: The symptom is likely to occur frequently. (Caution required)

B: The symptom may occur under certain conditions, but likeliness is assumed very low in practical usage.

C: The symptom is unlikely to be recognized by the user, and no practical issues are assumed.

Part 3

Appendix

1. PIXMA MP760 Specification

<GENERAL>

| | | |
|--|---------------|--|
| Printer | | YES |
| Scanner | | YES |
| Copy | | YES |
| Facsimile | | NO |
| Memory Card | | YES |
| Memory Card Slot | | YES |
| Media | | CF(Type I/II) Micro Drive Smart Media SD/miniSD* Multi Media Card xD-PictureCard* Memory Stick/Memory Stick Pro/Memory Stick Duo* /Memory Stick Pro Duo* /Magicgate Memory Stick Duo* |
| | | * At Adapter |
| Data Storage | READ WRITE | YES YES |
| Photo-Direct print | | YES |
| Applicable Image | | J PEG (DCF/CIFF/Exif2.21under /J FIF) DPOF |
| Supported layouts | | Plain paper A4/Letter: Borderless, Print index (up to 80 images) Photo Paper Pro, Super White Paper, High Resolution Paper, Glossy Photo Paper, Photo Paper Plus Semi-Gloss, Matte Photo Paper: A4: Borderless, Print index A4 (up to 80 images) |
| Camera Direct (Pictbridge) Paper size | | Default (Photo Paper Plus Glossy 10 x 15 cm/4" x 6"), 10 x 15cm/4" x 6" (Photo Paper Plus Glossy, Photo Paper Pro, Photo Paper Plus Semi-Gloss, Glossy Photo Paper, Photo Sticker*), 13x 18 cm/5" x 7" (Photo Paper Plus Glossy)* * , A4/8.5" x 11" (Photo Paper Plus Glossy A4/Letter, Photo Paper Pro A4/Letter,Photo Paper Plus Semi-Gloss A4/Letter, Glossy Photo Paper A4/Letter), Credit Card size (Glossy Photo Paper)* * This setting is available for specified Canon Cameras only. * * If using a Canon PictBridge-compatible camera, you can select it. |
| | Layout | Default (Borderless), Borderless, Bordered, 2-up/4-up/9-up/16-up* * When 4" x 6" is selected from " Paper size ", these options may be available in " Layout" . |
| | Print Modes | DPOF support |
| Camera Direct (Bubble Jet Direct) Compatible Paper | | Card # 1 (Photo Paper Pro 4" x 6" /101.6 x 152.4 mm),Card # 2 (Photo Paper Plus Glossy, Photo Paper Plus Semi-Gloss,or Glossy Photo Paper 4" x 6" /101.6 x 152.4 mm),Card # 3 (Photo Paper Plus Glossy 5" x 7" /127.0 x 177.8 mm),LTR (Photo Paper Pro, Photo Paper Plus Glossy, Photo PaperPlus Semi-Gloss, or Glossy Photo Paper |

| | | |
|-------------------|----------------------|---|
| | | Letter size)A4 (Photo Paper Pro, Photo Paper Plus Glossy, Photo Paper Plus Semi-Gloss, or Glossy Photo Paper A4 size) |
| | Layout Print | Standard: Borderless, Bordered, Index Print: 16-80 images (Depending on the size of print media) |
| Photo Index Sheet | | YES |
| Power Consumption | MAX | Approx. 40W |
| | Standby | Approx. 20W |
| Noise | Standby | None |
| | Copy(Cassette, Copy) | 52dB (A) max. |
| Durability | Unit | 5 years |
| | Scanning Section | 15,000 pages |
| | Printing Section | 18,000 pages (Color/Black&White) |
| Size | Including Tray | 19 1/8 in.(W) x 18 5/8 in.(D) x 12 3/8 in.(H) (W486mm* D472mm* H314mm) (With the Paper Support and the Paper Output Tray closed) 19 1/8 in.(W) x 21 1/8 in.(D) x 12 3/8 in.(H) (W486mm x D538mm x H314 mm (H)) (With the Paper Support, the Paper Output Tray, and both extensions opened) |
| Weight | Standard | 13.7kg (Including Print Head and Ink Tank + 0.2kg) |

<Scanner Function>

| | | |
|-------------------------------|----------------|----------------------|
| Type | | Flatbet |
| Reading System | Sensor Type | 2400dpi staggerd CCD |
| ADF | | NO |
| Reading Resolution | | 2400 x 4800 dpi max |
| Gradation bit | Color (Input) | 48bit |
| | Color (OutPut) | 24bit |
| | Gray (Input) | 16bit |
| | Gray (Output) | 8bit |
| Maximum Document Size | | 216 mm x 297 mm |
| Effective Scanning Width (mm) | | 216 mm |
| Local Scan Driver | TWAIN | YES |
| | WIA | YES |

<Printer Function>

| | | |
|---|-----------------|--|
| ASF | | YES |
| Size | | A4, A5, B5, 4" x 6" , LTR, LGL |
| Paper Materials | | Plane paper, other |
| Printing resolution | | 4800 x 1200 dpi |
| Printing Speed (page/min) | | 25 ppm (BK) / 17 ppm (Color) |
| Printing direction | | Bi-direction |
| Printable area (none printable area form each edge) | | 3.4mm right/left edge, 3mm top, 2mm bottom |
| Printing Cartridge | | |
| Product Name | | QY6-0049 |
| Print Yield | Black (BCI3eBK) | approx. 900 pages (Black 1,500 character std pattern, Plain std mode) |
| | Yellow (BCI-6Y) | approx. 1,300 pages (ISO J IS-SCID No.5 pattern, Plain std mode) |
| | | approx. 480 pages |

| | | |
|-------------------------|------------------|---|
| | Magenta (BCI-6M) | (ISO J IS-SCID No.5 pattern, Plain std mode) approx. 480 pages |
| | Cyan (BCI-6C) | (ISO J IS-SCID No.5 pattern, Plain std mode) approx. 640 pages |
| | Black (BCI-6BK) | (ISO J IS-SCID No.5 pattern, Plain std mode) approx. 2,000 pages |
| | | (ISO J IS-SCID No.5 pattern, Plain std mode) |
| Ink Remaining Detection | | YES |
| Detection Method | | prism + Dot count |
| Paper Capacity | | Maximally 50 sheets (Plain 75g/m ²) |
| Borderless Printing | | YES |
| Silent Mode Printing | | YES |
| CD-R Label Print | | YES |

<Copy Function>

| | | |
|------------------------------------|--|--|
| Copy Print Resolution | Black & White Color | 600 x 600 dpi (Normal mode) 1200 x 1200 dpi (Normal mode) |
| Copy speed | Ink Jet Black & White (Draft) Color(Fast) | 25 ppm 17 ppm |
| Scanning Density Adjustment | | YES |
| Manual | | 9 positions |
| Multipule Copies | | 99 |
| Preset RE Ratio | | YES |
| Enlarge | Max. 4" x 6" -> TR 5" x 7" -> TR | YES YES YES |
| Reduction | 100% A4 -> TR | YES YES |
| Zoom | | YES |
| Zooming Range | | 25-400 % |
| Auto Magnification Selection (AMS) | | YES |
| Image Quality | B & W Color | Fast, Normal, Fine (photo) Fast, Normal, Fine (photo) |
| Energy Saving Mode | | YES (15 min/ 1 hour/ 4 hour/ 8 hour) |
| Image Combination | | YES |
| 2 in 1 | | YES |
| 4 in 1 | | NO |
| Image Repaet (Auto/Manu) | | YES/YES |
| Mirror Image | | NO |
| Seal Copy | | YES |
| Name Card Copy | | YES |
| Postcard Copy | | NO |
| Borderless Copy | | YES |
| Poster | | NO |
| Fit to Page | | YES |
| Entire Document | | NO |

<Function>

| | | |
|-------------------|------------------------------|---|
| Memory Backup | Backup Contents Backup IC | User Data, Service Data etc. 128 kbit EEPROM (battery unnecessary) |
| Image Data Backup | | NO |
| Image Memory | Approx 5MB | |